

Part # U3050

7-14-99

BREMEN TECHNOLOGIES

INSTALLATION INSTRUCTIONS FOR BREMEN RUNNING BOARDS
425 Industrial Drive Bremen, Indiana 46506

INSTALLATION PACKAGE PART LIST

ITEM	QUANTITY
main bracket, 20" long	4
angle iron, 3" long	8
metal strap, 8" long	4
metal strap, 10" long	4
3/8" hex-head self-tapping screws	48
1/2" hex-head bolt, nut & lock-washer	24
3/8" hex-head wood screws	8

TOOLS

- flat clamp vice-grips, eight inch (three)
- ratchet wrench with socket, 1/2"
- combination wrench, 1/2"
- variable speed drill
- hex-head driver bit, 3/8"
- drill bit, 1/4"
- drill bit, 11/32"

Before you begin

1. Read through the instructions and test fit running boards.
2. Paint running boards; make sure they are dry before handling.

Part I Fasten the running board to the vehicle body

1. Pre-drill 1/4" holes in the running board along the mounting flange (see Fig. A)
2. Fit the running board onto the vehicle, use an arrangement of vice-grip clamps to hold the running board in place.
3. For *pick-up trucks*: The cab & bed running board sections must line up with each other, make adjustments if necessary (see text box in Figure B).
4. Using a variable speed drill and a 3/8" hex-head driver bit, fasten the running board to the vehicle body with self-tapping screws (one screw through the center of each hole, pre-drilled in the running board).

Part II Install the support brackets

To provide safe, reliable service, the running boards must be properly supported with brackets (see Figure B). The bracket must be secured to the vehicle at two specific locations: inboard and outboard (see Figure C).

1. Secure the main bracket at the inboard location to the frame or sub-floor (see Figures D, E, F & G)
2. Fasten the main bracket to the wood reinforced step portion of the running board using the wood screws (see Figure C).
3. Attach the outboard strap to the main bracket (do not tighten), then fasten the out board strap to the "double metal pinch flange" with a hex-head bolt (You may need to use the three-inch angle iron; see figures H & I).
4. Make sure all fasteners are tight.

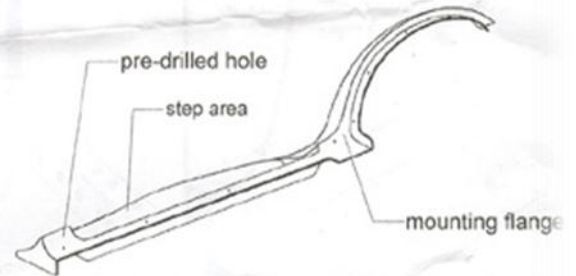

Fig. A. In order to fasten the running boards to the vehicle, we provide you with thirty self-tapping screws (15 per side of vehicle) each screw requires a pre-drilled hole (1/4") in the mounting flange.

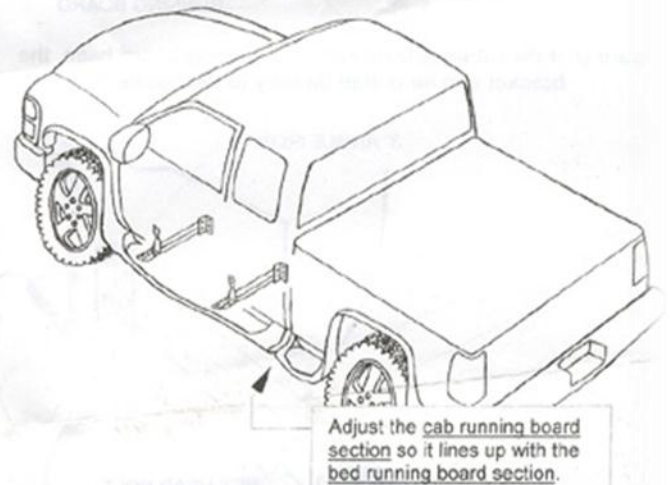

Figure B. Brackets support the running boards from underneath.

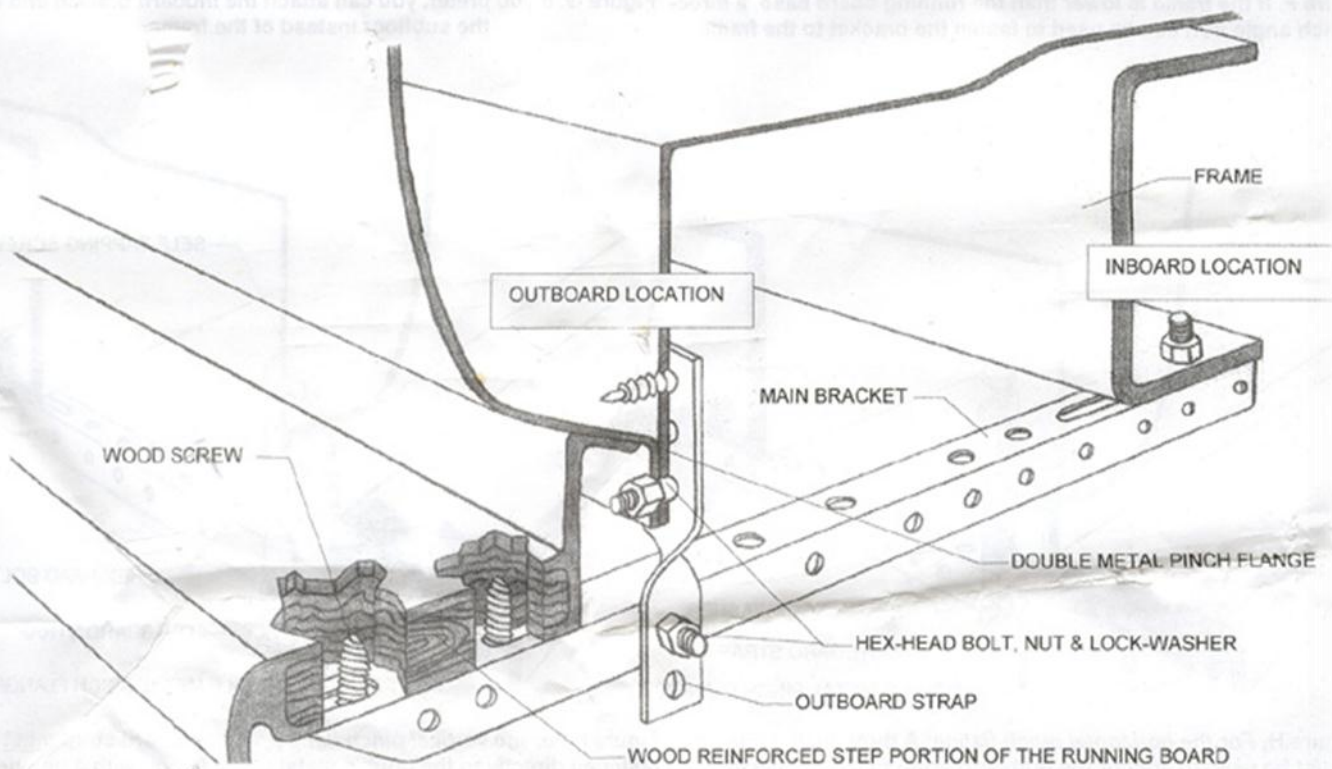

Figure C. The main bracket is screwed to the running board and is anchored to the vehicle at the inboard and outboard locations.

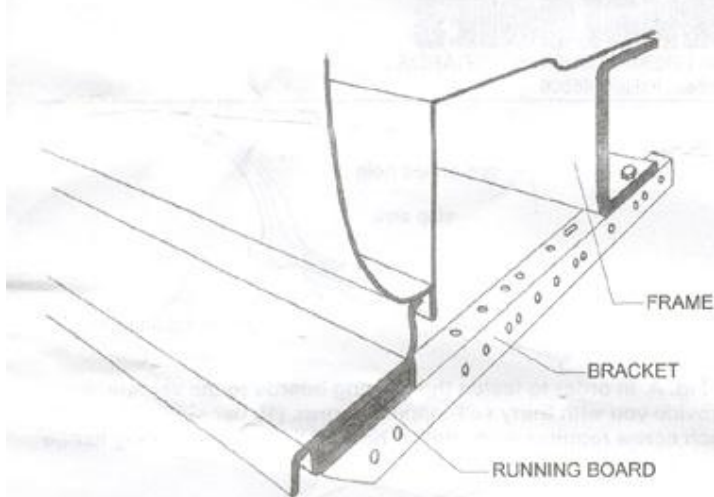

Figure D. If the frame is level with the running board base, the bracket can be bolted directly to the frame.

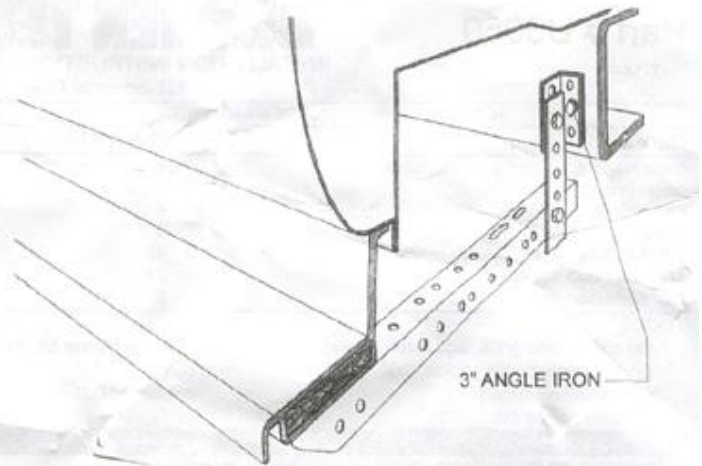

Figure E. If the frame is higher than the running board base, a three-inch angle iron and metal strap should be used to "hang" the bracket from the frame

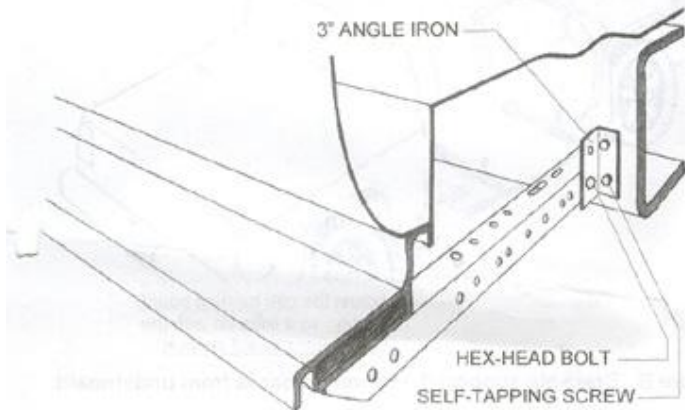

Figure F. If the frame is lower than the running board base, a three-inch angle iron can be used to fasten the bracket to the frame

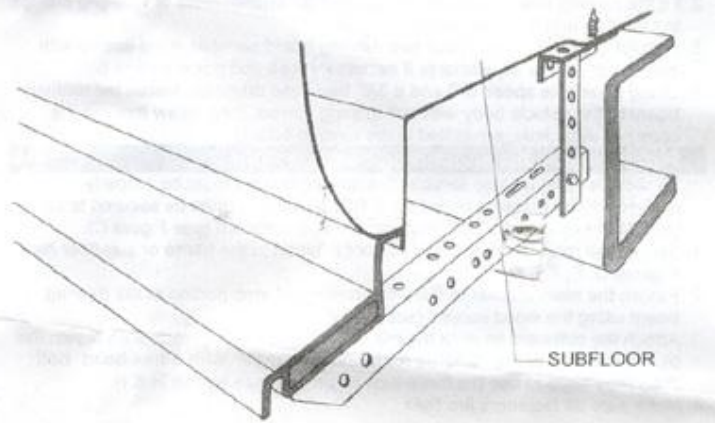

Figure G. If you prefer, you can attach the inboard bracket end to the subfloor instead of the frame

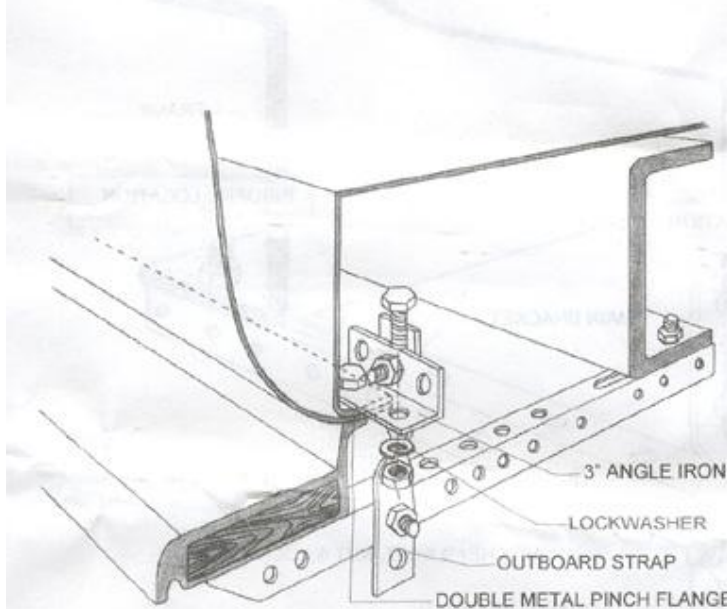

Figure H. For the horizontal pinch flange: A three-inch angle iron must be used to anchor the outboard strap to the double metal pinch flange with three hex-head bolts, nuts & lock-washers

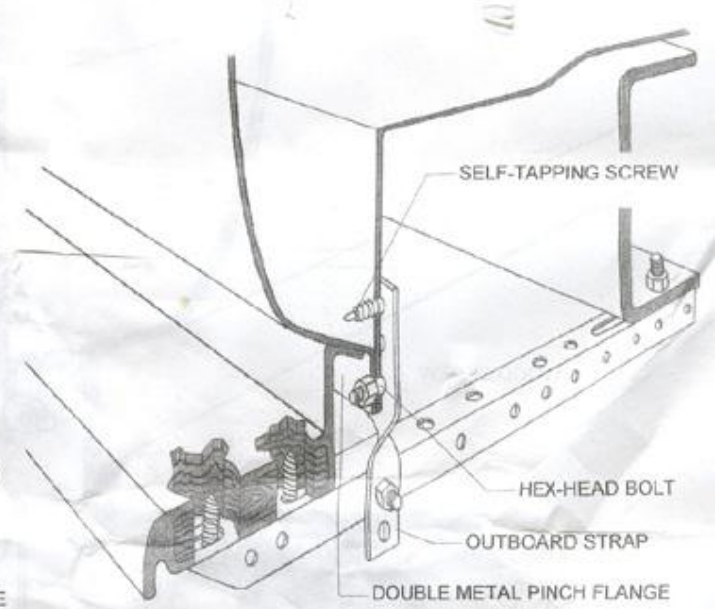

Figure I. For the vertical pinch flange: The outboard strap must be fastened directly to the double metal pinch flange with a hex-head bolt, nut and lock-washer