

RUNNING BOARD

Components:

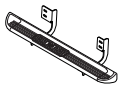

Driver Side
Running Board Assembly
(Brackets already attached)
Qty. 1

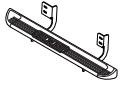

Passenger Side
Running Board Assembly
(Brackets already attached)
Qty. 1

Hardware:



M10 X 30MM
Hex Head Bolt
Qty 4

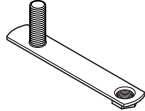

M12 Bolt +
M10 Nut Plate
Qty 4



M12 Flat
Washers
Qty 4



M12 Lock
Washers
Qty 4



M12 Hex
Head Nut
Qty 4

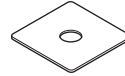

Plastic
Push Nut
Qty 4



M10 Flat
Washers
Qty 4



M10 Lock
Washers
Qty 4



M8 X 30MM
Head Bolt
Qty 4

1. Remove all contents from the package and check stainless steel running boards for any damage. Also, verify that all components and hardware listed above are included before you begin installation.

2. Locate factory holes in six (6) places underneath body mount.

Passenger Side

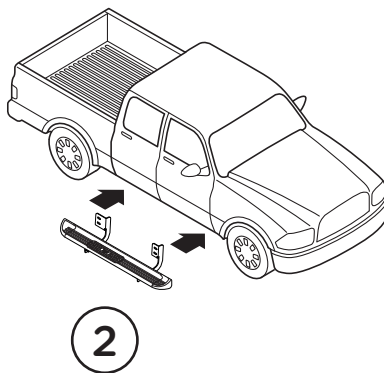

Driver Side

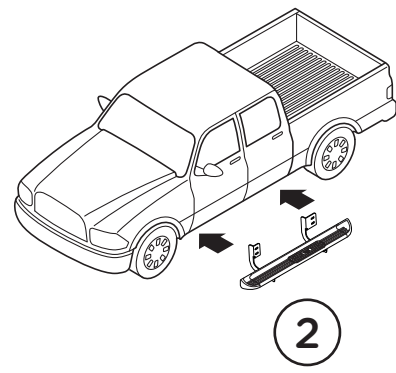

3. Remove the Tape covering the factory oblong hole in the Rocker Panel located above the two (2) hex holes.

4. Place the Plastic Push Nut onto the stud of the M12 Bolt + M10 Nut Plate (4b). Then, slide the M12 Bolt + M10 Nut Plate into the hole in the rocker panel as shown (4a).

5. Line up each bracket to the Bolt + Nut Plate located in the Rocker Panel.

Fasten the Bracket onto the M12 Bolt using one (1) M12 Flat Washer, one (1) M12 Lock Washer and one (1) M12 Hex Head Nut.

Fasten the Bracket to the threaded nut using one (1) M10 Flat Washer, one (1) M10 Lock Washer and one (1) M10 x 30MM Hex Head Bolt.

If threaded inserts already exist in Rocker Panel holes, use (1) M8 Flat Washer, one (1) M8 Lock Washer and one (1) M8 x 30MM Hex Head Bolt.

Repeat these steps for driver side installation. When all hardware is in place, everything must be tightened. See Page 1 for Torque Specifications.

