

# RUNNING BOARD

## Components:

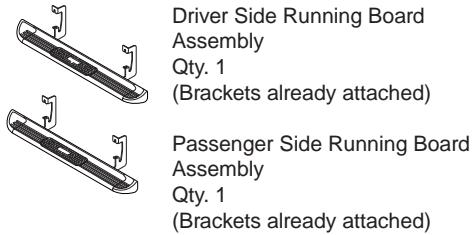

## Hardware:

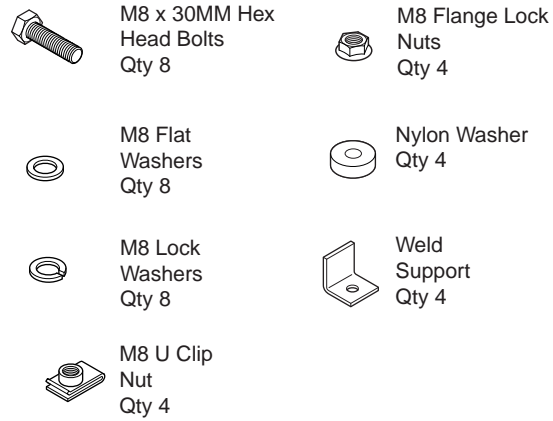

1. Remove all contents from the package and check stainless steel tubes for any damage. Also, verify that all components and hardware listed above are included before you begin installation.

2. Begin installation on passenger's side of vehicle.

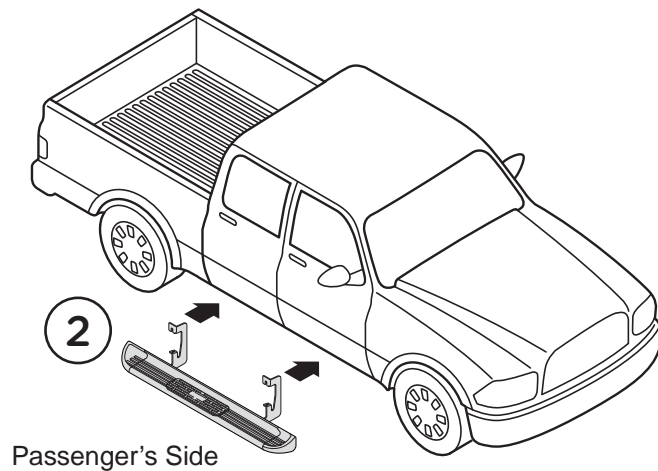

3. Install the M8 U Nut Clips into the holes in the Rocker Panel as shown (3a and 3b). Some vehicles may have threaded inserts in the Rocker Panel already. If so, please disregard the M8 U Nut Clip. Install these U Nut Clips so that the threads are to the inside of the rocker panel. Be careful not to drop the U Nut Clips inside of the rocker panel.

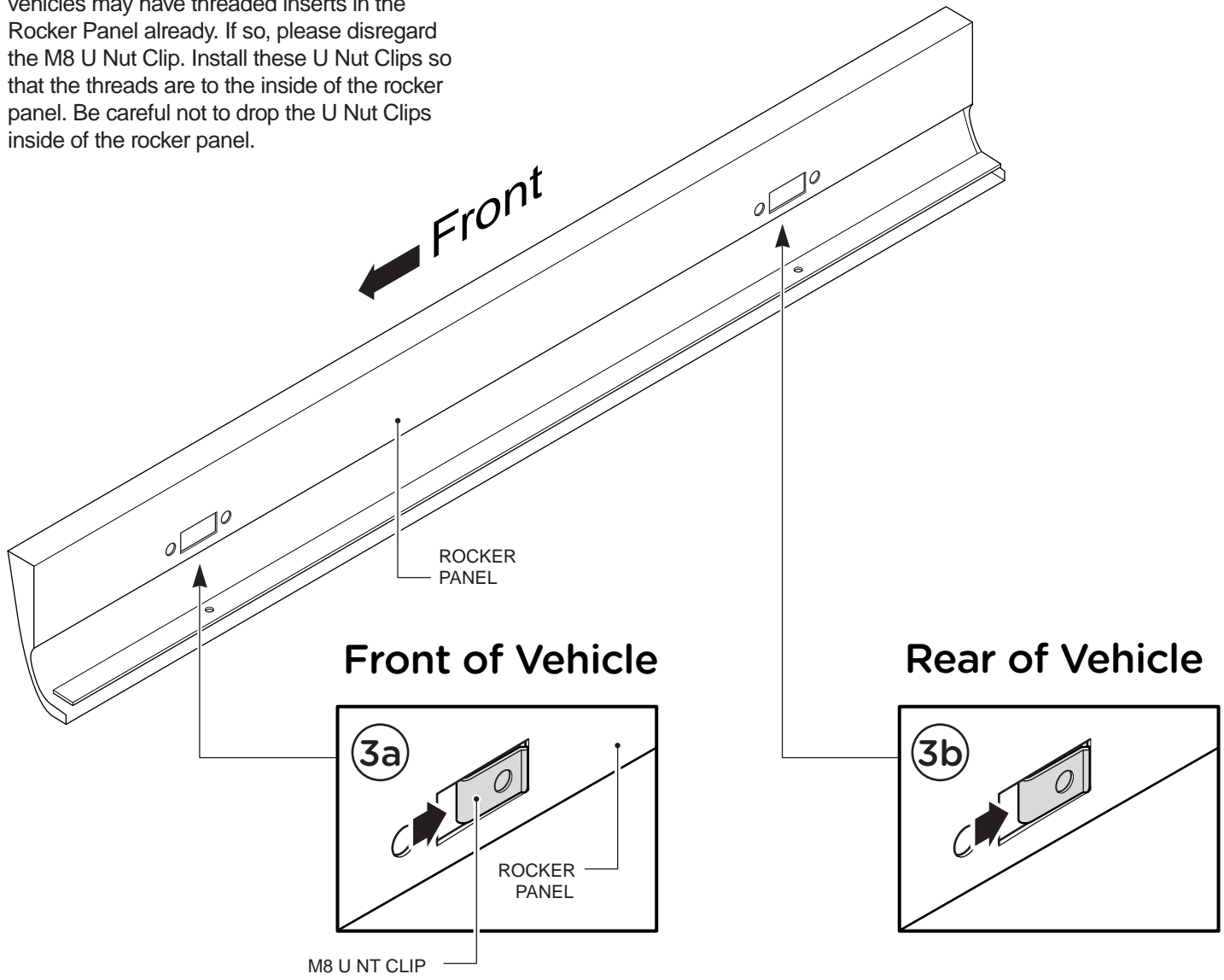

4. Align the Brackets up with the U Nut Clips or the pre-threaded holes in the Rocker Panel.

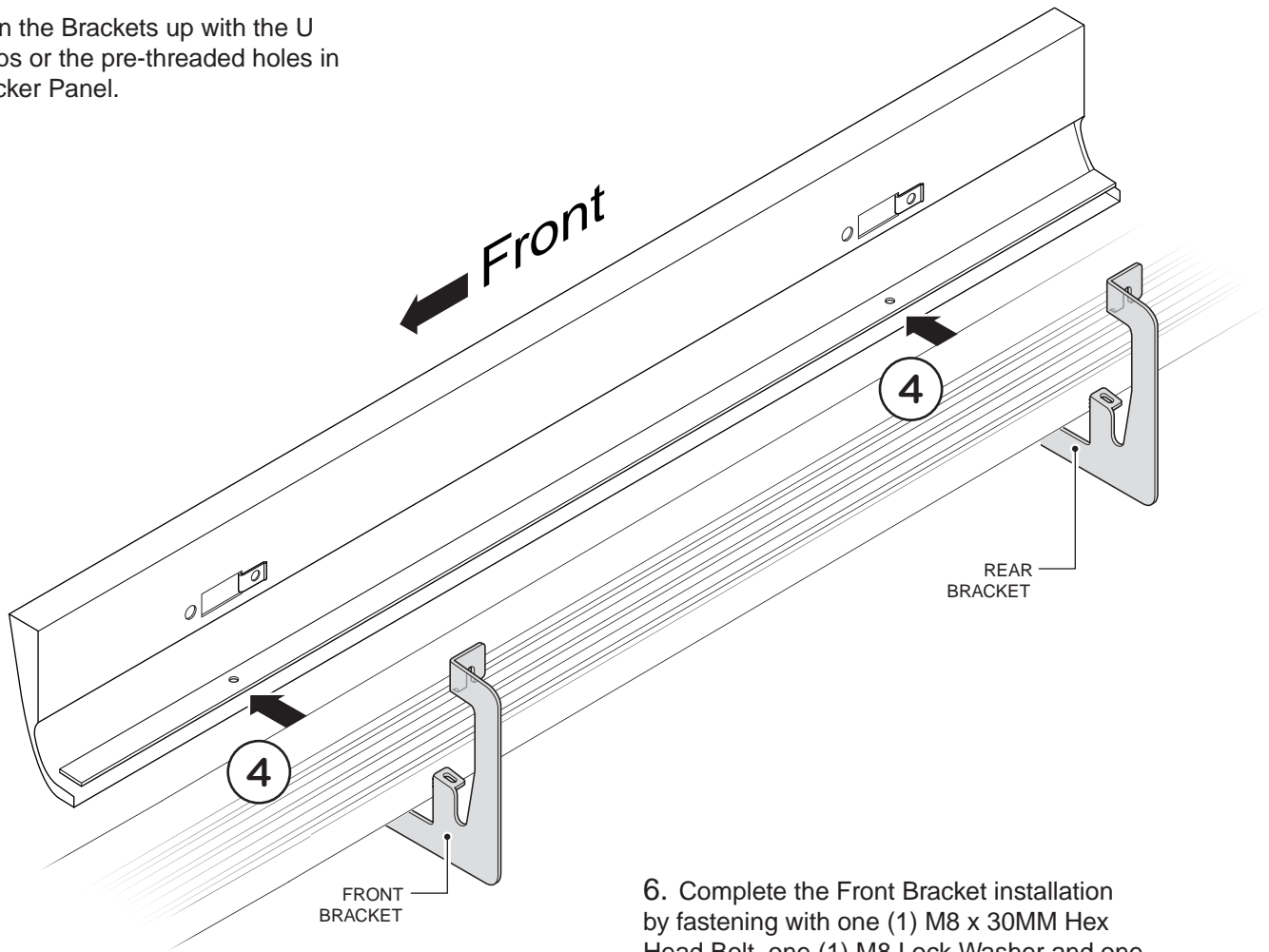

5. Fasten the lower portion of the Front Bracket using one (1) M8 Flange Lock Nut, one (1) Weld Support, one (1) Nylon Washer and one (1) M8 X 30MM Hex Head Bolt. Repeat for Rear Bracket.

6. Complete the Front Bracket installation by fastening with one (1) M8 x 30MM Hex Head Bolt, one (1) M8 Lock Washer and one (1) M8 Flat Washer. Repeat for Rear Bracket.

Repeat these steps for driver side installation. When all hardware is in place, everything must be tightened. See Page 1 for Torque Specifications.

