

# INSTALLATION INSTRUCTIONS

## PRO TRAXX 6 OVAL STEP BARS

### APPLICATION:

2007-2017 Chevrolet Silverado / GMC Sierra 1500/2500/3500  
Extended/Double/Crew Cab (Includes Diesel w/DEF)

### PART NUMBER:

21-63710, 21-63715, 21-63720, 21-63725

ITEM	QUANTITY	DESCRIPTION	TOOLS NEEDED
1,2	2	STEP BAR, DRIVER (1) AND PASSENGER (2)	13MM WRENCH
3	1	PASSENGER FRONT UPPER BRACKET (ALL INLC. DEF)	13MM SOCKET
4	1	PASSENGER FRONT LOWER BRACKET (ALL INLC. DEF)	CUTTING TOOL
5	5	BRACKETS, DRIVER OR PASSENGER	RATCHET
6	11	M8 CLIP-ON NUTS	TORQUE WRENCH
7	25	M8 HEX HEAD BOLTS	
8	25	M8 FLAT WASHERS	
9	25	M8 LOCK WASHERS	
10	1	M8 BOLT PLATE	
11	1	M8 NYLOCK NUT (USE WITH BOLT PLATE)	

**ANTI-SEIZE LUBRICANT MUST BE USED ON ALL STAINLESS STEEL FASTENERS TO PREVENT THREAD DAMAGE AND GALLING**

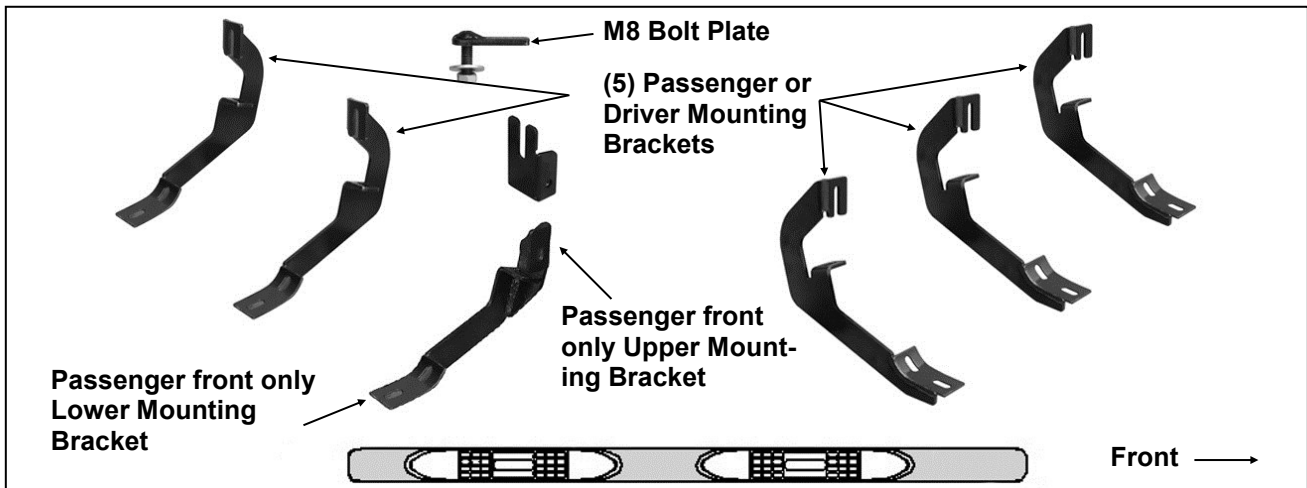

### PROCEDURE

- Remove contents from box, verify if all parts listed are present and free from damage. Carefully read and understand all instructions before attempting installation.  
**Failure to identify damage before installation could lead to a rejection of any claim.**
- Start the installation under the driver side of the vehicle. **For Extended and Double Cab:** Locate the 4 tabs along the bottom edge of the body, (pinch weld). Mounting Brackets will bolt to the 1st, 2nd, (just in front of center of cab), and 4th mounting tabs, (**Figure 1A**). **For Crew Cab:** Locate the 5 tabs along the bottom edge of the body, (pinch weld). Mounting Brackets will bolt to the 1st, 2nd, (just in front of center of cab), and 5th mounting tabs, (**Figure 1B**).  
Directly above each tab is a top mounting location on the side of the body panel. Hold a Bracket up in place to help determine the mounting holes to use along the body.

**Assistance is recommended. On models with DEF tank, select a flat, level area for installation. May require cutting.**

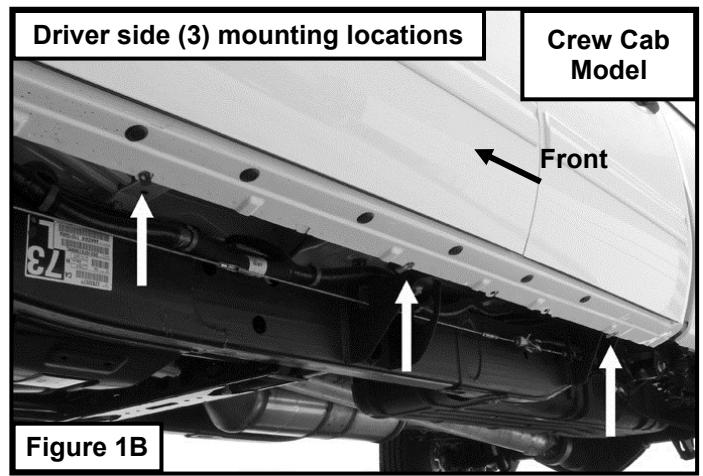
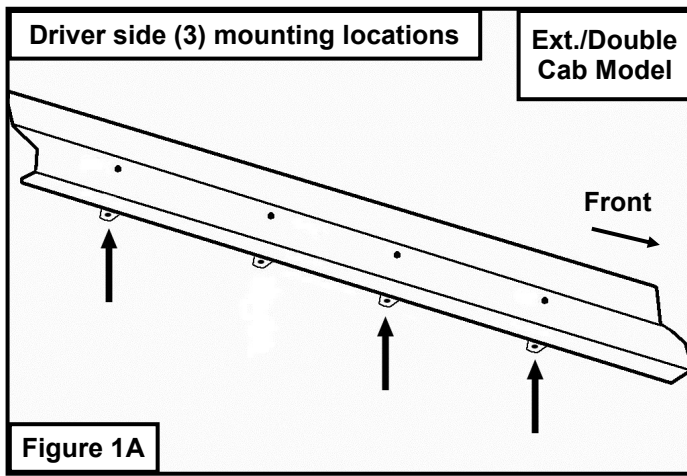

3. Determine the correct procedure for your model year and each Bracket location.

**Bottom mounting location on the edge of the pinch weld.**

**Flat tab on pinch weld with factory installed weld nut:** Thread hex bolt into weld nut from the backside-down to clear paint from threads, (Figure 2).

**Flat tab on pinch weld with hole:** Select (1) M8 Clip Nut. Slide the Clip Nut over the tab with the nut facing up behind the tab, (Figures 3 - 5). Line up threaded nut with hole in tab. Repeat for each mounting location.

**Top mounting location on the side of the body panel.**

**Models with factory installed threaded insert in body panel:** Thread M8 Hex Bolt into threaded insert to clear paint as required, (Figures 2 & 3).

**Large and small hole in side of body panel:** Remove the rubber plug from the larger hole, (Figure 4). Select (1) M8 Clip Nut. Slide the Clip Nut into the larger hole. Line up the threaded nut with the smaller hole, (Figure 5).

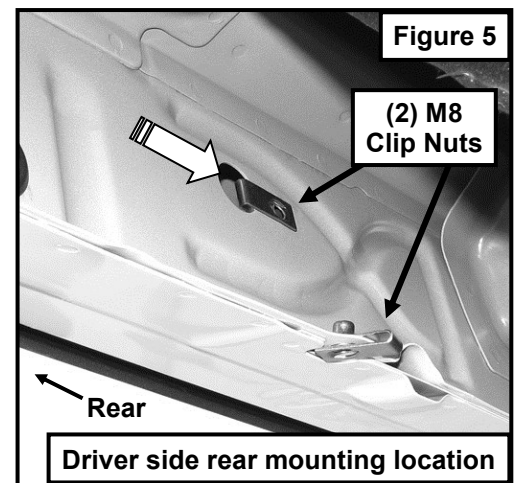
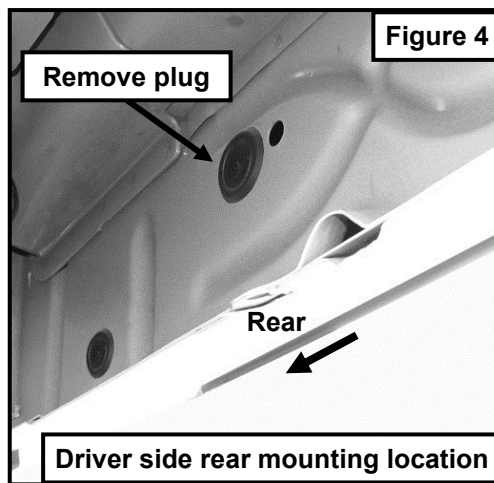
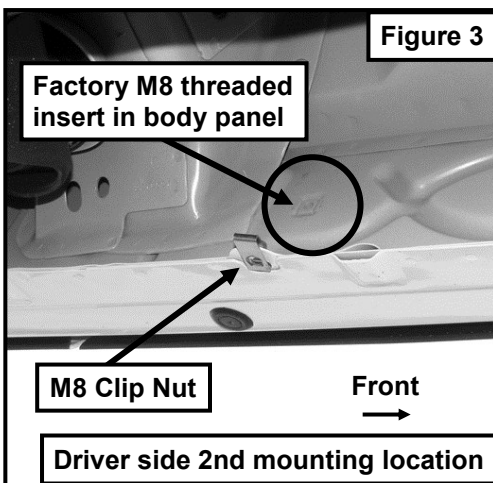
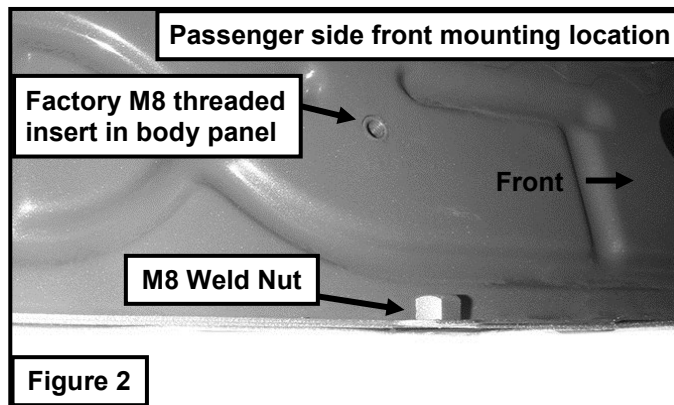

Westin Automotive Products, Inc.  
W. 320 Covina Blvd  
San Dimas, Ca. 91773

Thank you for choosing Westin products  
for additional installation assistance please call  
Customer Service (800) 793-7846

www.westinautomotive.com

DATE: 2/23/17

4. Select (1) Mounting Bracket. **NOTE:** (5) Brackets are universal and will fit left or right side. Bolt the Mounting Bracket to the Clip Nuts and/or the factory threaded holes with (2) M8 Hex Bolts, (2) M8 Lock Washers and (2) M8 Flat Washers, (**Figures 6 & 7**). Snug but do not fully tighten the hardware.
5. Repeat **Steps 2-4** to install the (2) remaining driver side Brackets.

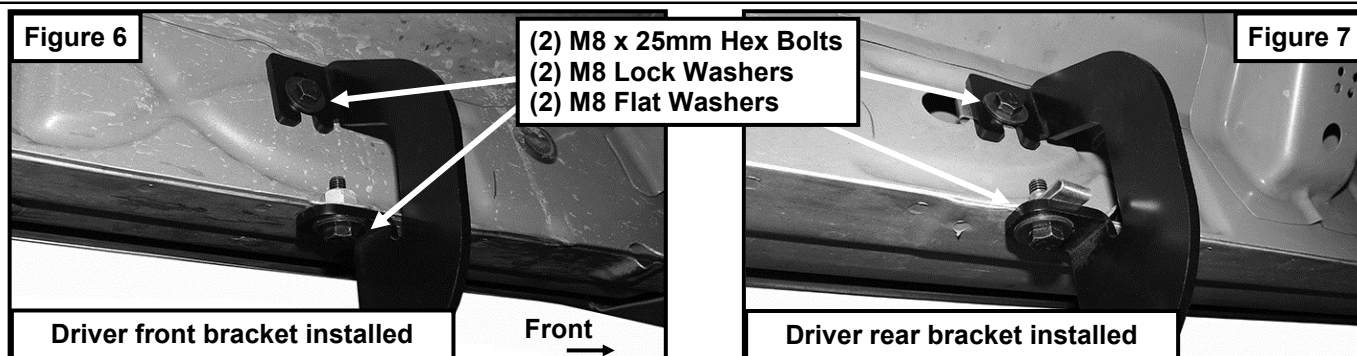

6. Select the driver sidebar. Carefully position the Driver Sidebar onto the (3) Mounting Brackets. **IMPORTANT:** Do not slide, (front to back or rotate), the Sidebar on the Brackets or damage to the finish on the Sidebar may result. Attach the Sidebar to the Mounting Brackets with (6) M8 x 25mm Hex Bolts, (6) M8 Lock Washers and (6) M8 Flat Washers, (**Figure 8**). Do not tighten hardware.
7. Level and adjust the Sidebar and tighten all hardware.

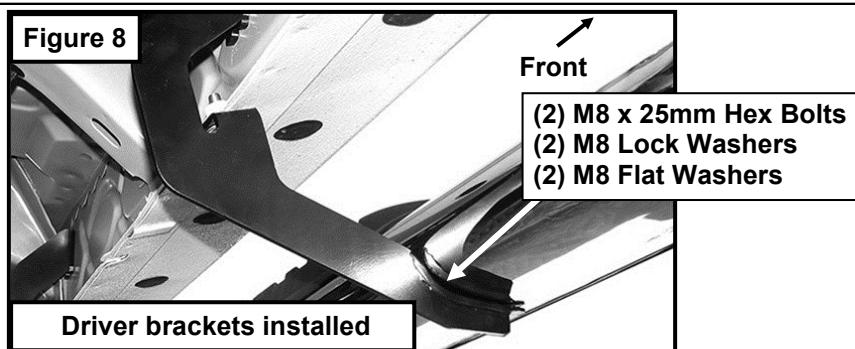

8. Move to the passenger side of the vehicle. On the passenger side, determine if the vehicle is equipped with a plastic diesel exhaust fluid (DEF) tank, (**Figures 9 & 10**). **Models without DEF tank, skip to Step 9.**  
**Models with DEF tank:** The tank sits close to the side of the body. The passenger front upper and lower Bracket can be installed but room is limited. For 2011-16 models it may be easier to drop the tank down to access the inner side of the body panel for upper bracket installation. Tank will not need to be removed, only dropped down for access to mounting location. **IMPORTANT:** If tank is full, it will be very heavy and assistance is highly recommended to avoid injury or damage to the vehicle or the tank. It is recommended that installation is performed when the DEF tank is low on fluid before dropping the tank.  
**For 2017+ models it is recommended to only remove the DEF cover. It is very difficult to lower the DEF tank.**
  - a. On models with plastic lower tray under tank, remove the (3) hex bolts attaching the tray to the frame, (**Figure 9**), and remove the tray. **2017 2500/3500 models:** Remove the (4) hex bolts attaching the plastic cover to DEF tank, (**Figure 10A**) and remove plastic cover, (**Figure 10B**).
  - b. Release the tank filler hose. Release the plug for the sending unit on the top of the tank.
  - c. Support the tank with a floor jack. Place a smooth flat surface between the floor jack and the tank to avoid damaging the plastic tank. Do not push up on the tank; only support the weight of the tank with the jack.
  - d. Remove the (2) bolts securing the tank straps to the vehicle, (**Figure 11**). Tilt the straps to release from the brackets. Slowly lower the tank until the top of the tank is almost visible. Use blocks or stands to support the tank while installing the front Upper and Lower Brackets. Proceed to **Step 9**.



Westin Automotive Products, Inc.  
W. 320 Covina Blvd  
San Dimas, Ca. 91773



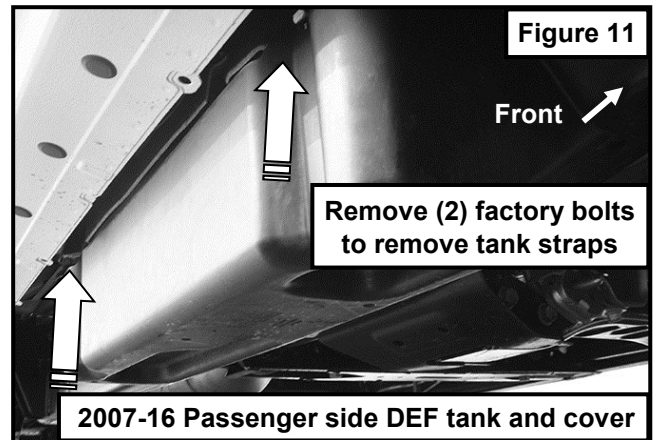
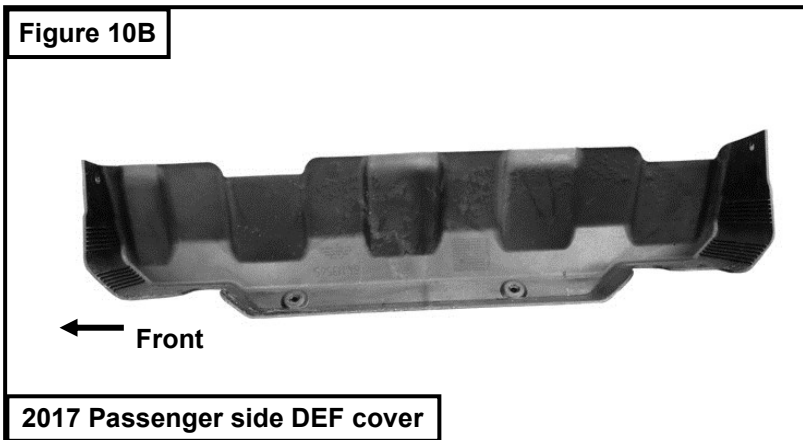
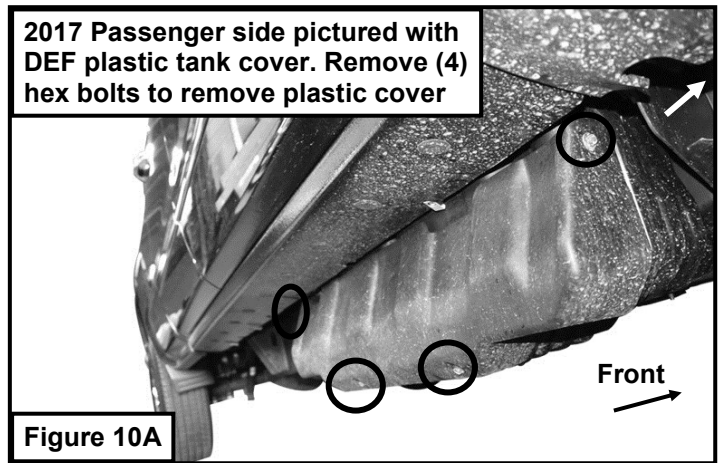
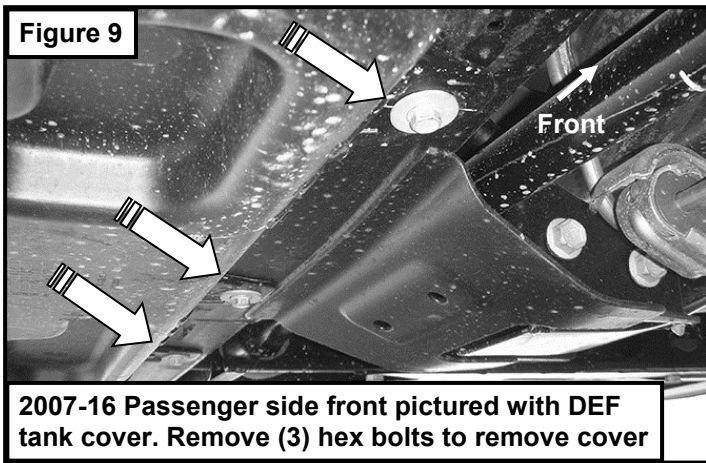

9. Locate the first tab on the edge of the pinch weld, (Figures 2 - 4, 13 & 15). Select the Upper Bracket, (Figure 12). Repeat Steps 3 & 4 to attach the passenger front Upper Bracket to the side of the body panel, (Figure 13). Do not tighten hardware at this time.

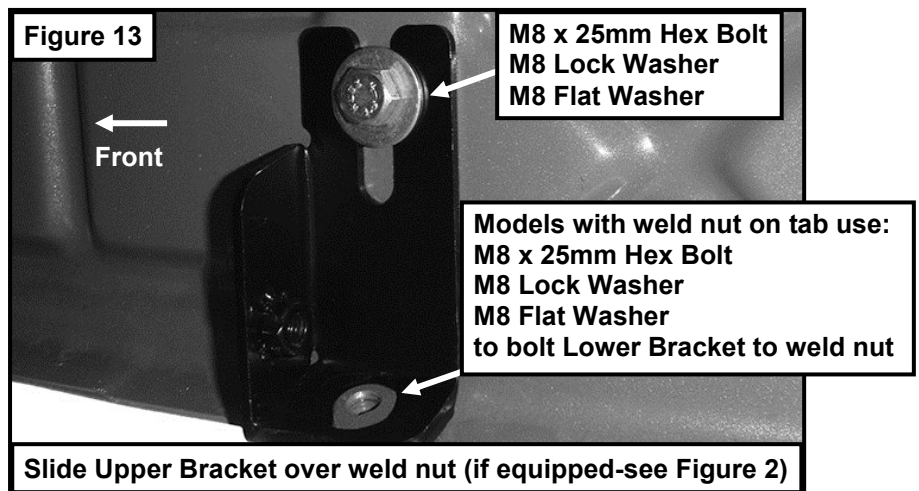
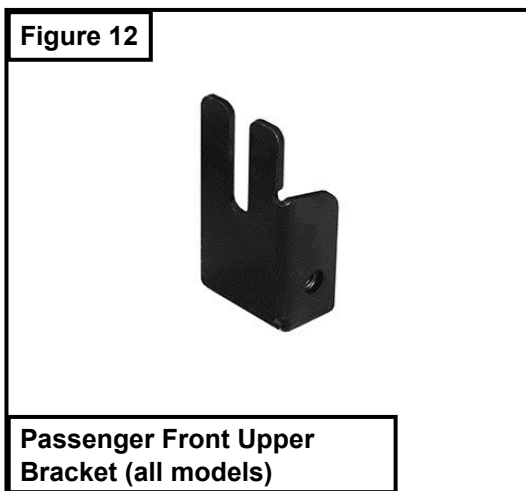

10. Line up the hole in the bottom of the Upper Bracket with the hole in the tab on the pinch weld.
- a. **Models with a weld-nut:** Slide the Bracket over the weld-nut, (**Figure 13**). Attach the Lower Bracket to the bottom of the body and weld-nut with (1) M8 x 25mm Hex Bolt, (1) M8 Lock Washer and (1) M8 Flat Washer, (**Figures 16 & 20**). Leave loose at this time.
  - b. **Models with flat tab and hole:** Insert the M8 Bolt Plate down through the hole in the Upper Bracket and mounting tab, (**Figures 14 & 15**). Attach the Lower Bracket to the bottom of the body and Bolt Plate with (1) M8 Flat Washer and (1) M8 Nylon Lock Nut, (**Figures 16 & 20**). Leave loose at this time.
11. Line up the side tab on the Lower Bracket with the threaded hole in the side of the Upper Bracket. Attach the Lower Bracket to the Upper Bracket with (1) M8 x 25mm Hex Bolt, (1) M8 Lock Washer and (1) M8 Flat Washer, (**Figure 20**). Leave loose at this time.

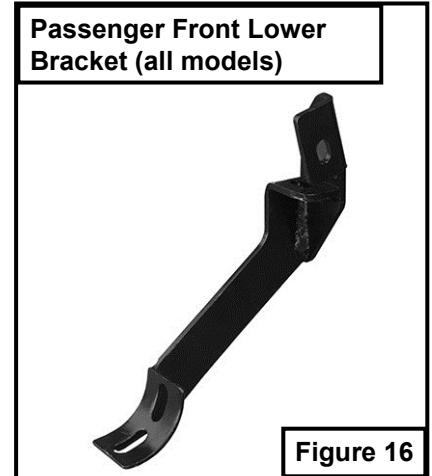
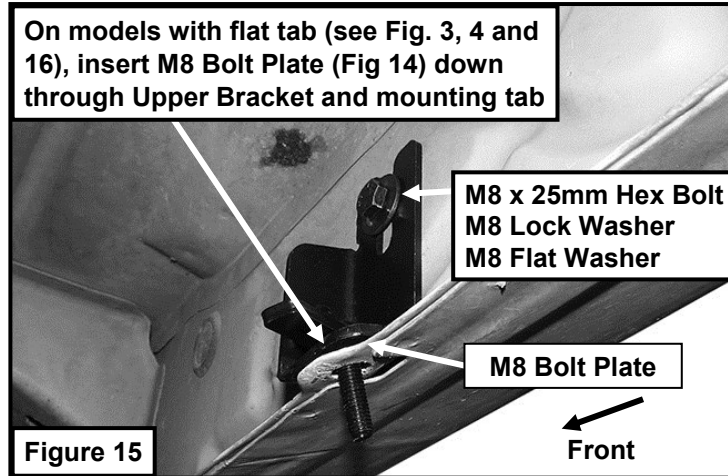
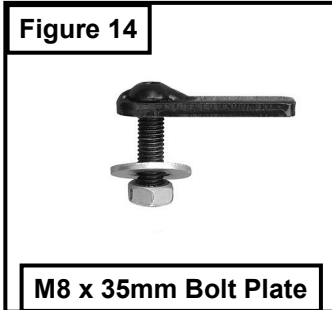

12. Repeat **Steps 2 - 4** for the (2) remaining passenger side Bracket installations. **NOTE:** Cradles on Brackets installed on passenger side will face forward.
- a. **2017 2500/3500 DEF tank models:** Locate the 2nd tab bracket location along the bottom edge of the body, (pinch weld), (**Figure 17**). Hold the DEF cover in place and mark the 2nd Bracket location onto the cover, (**Figure 18**). Use a sharp knife or hacksaw blade to carefully cut a slot in the plastic cover to clear the 2nd Bracket, (**Figure 19**). Remove as little plastic as possible.

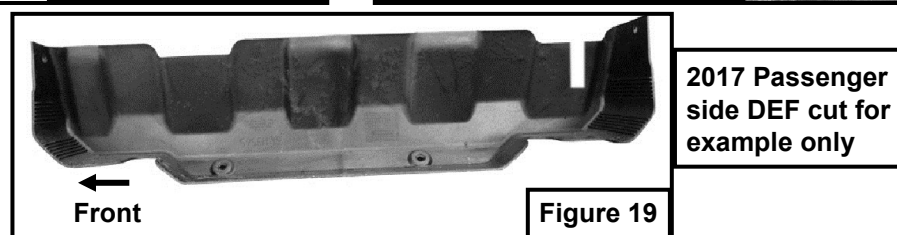
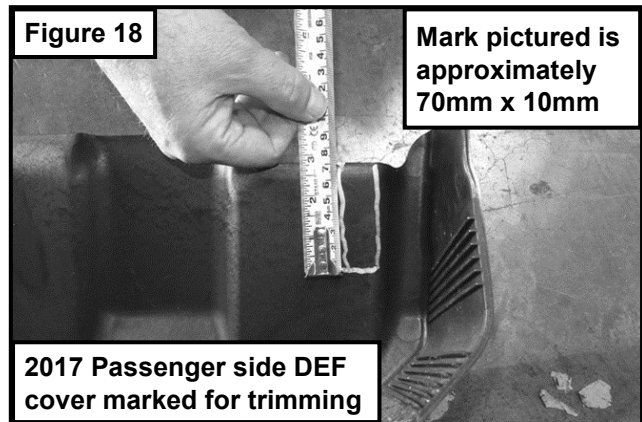
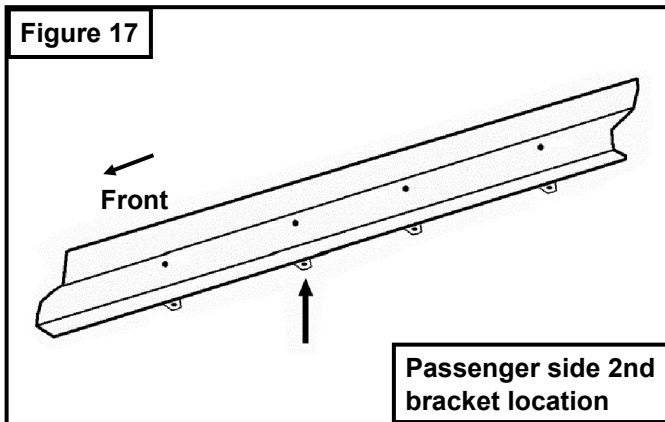



13. Repeat **Steps 6 & 7** to install the passenger Sidebar, (**Figure 21**).
14. Once the Sidebars are fully installed and all hardware fully tightened, reinstall the DEF tank and cover, if equipped, as described in **Steps 8 & 12**.
15. Do periodic inspections to the installation to make sure that all hardware is secure and tight.

**Models with weld nut on tab use:**  
**M8 x 25mm Hex Bolt**  
**M8 Lock Washer**  
**M8 Flat Washer**  
 to bolt Lower Bracket to weld nut

**All models use:**  
**M8 x 25mm Hex Bolt**  
**M8 Lock Washer**  
**M8 Flat Washer**

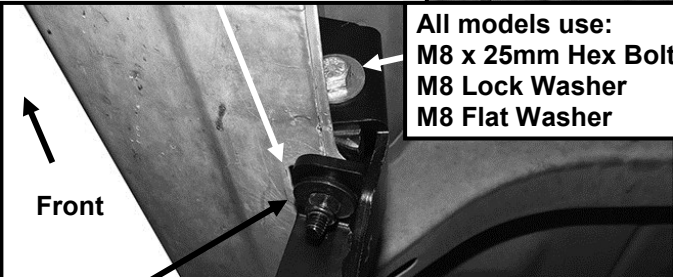

**On models with flat tab and M8 Bolt Plate (see Fig. 15) use:**  
**M8 Flat Washer**  
**M8 Nylon Lock Nut**  
 to attach Lower Bracket to Bolt Plate

**Figure 20**

**(2) M8 x 25mm Hex Bolts**  
**(2) M8 Lock Washers**  
**(2) M8 Flat Washers**

**Figure 21**

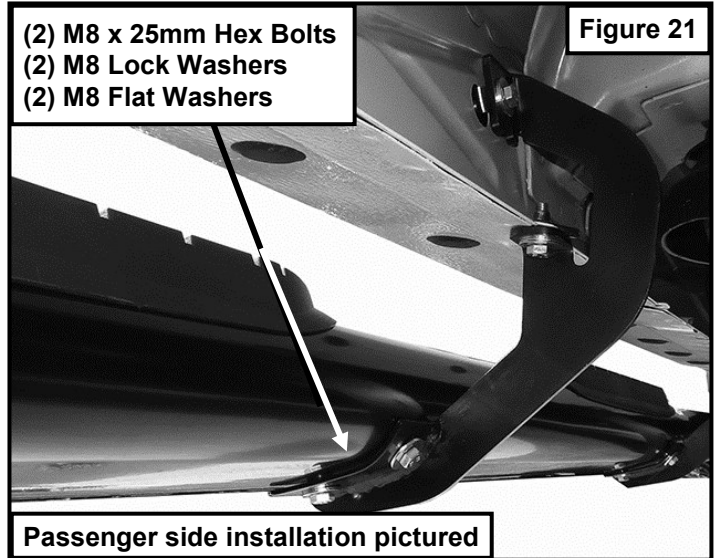

**Passenger side installation pictured**

**Extended Cab Shown**



**Installation Complete**

**Crew Cab Shown**



**Installation Complete**

**Care Instructions**

- REGULAR WAXING IS RECOMMENDED. DO NOT USE ANY TYPE OF POLISH OR WAX THAT MAY CONTAIN ABRASIVES.
- STAINLESS STEEL PRODUCTS CAN BE CLEANED WITH MILD SOAP AND WATER. STAINLESS STEEL POLISH SHOULD BE USED TO POLISH SMALL SCRATCHES.
- GLOSS BLACK FINISHES SHOULD BE CLEANED WITH MILD SOAP AND WATER.



Westin Automotive Products, Inc.  
 W. 320 Covina Blvd  
 San Dimas, Ca. 91773

Thank you for choosing Westin products  
 for additional installation assistance please call  
 Customer Service (800) 793-7846  
[www.westinautomotive.com](http://www.westinautomotive.com)  
 DATE: 2/23/17