

INSTALLATION INSTRUCTIONS

PRODUCT DESCRIPTION



APPLICATION:
2010 - 2018 Dodge Ram 2500/3500
PART NUMBER:
58-161015

CONTENT			
ITEM	QUANTITY	DESCRIPTION	TOOLS NEEDED
1	1	BUMPER ASSEMBLY	18MM SOCKET
2,3	2	MOUNTING BRACKET, DRIVER (2) AND PASSENGER (3)	19MM SOCKET
4	2	INNER LIGHT BRACKET	20MM SOCKET
5	2	OUTER LIGHT BRACKET	13/16" SOCKET
6	4	M12 HEX HEAD SCREW (YELLOW ZINC)	3/4" SOCKET
7	4	M12 HEX NUT (YELLOW ZINC)	1/2" DRIVE RATCHET
8	4	M12 SPLIT LOCK WASHER (YELLOW ZINC)	1/4" DRIVE RATCHET
9	8	M12 FLAT WASHER (YELLOW ZINC)	5/16" SOCKET
10	10	1/2" HEX HEAD SCREW (YELLOW ZINC)	PRY TOOL
11	10	1/2" SPLIT LOCK WASHER (YELLOW ZINC)	TORQUE WRENCH
12	20	1/2" FLAT WASHER (YELLOW ZINC)	WRENCH
13	10	1/2" HEX NUT (YELLOW ZINC)	EXTENSION
14	16	1/4" HEX FLANGE NUT (YELLOW ZINC)	
15	16	1/4" SQUARE NECK CARRIAGE BOLT (BLACK)	

ANTI-SEIZE LUBRICANT MUST BE USED ON ALL STAINLESS STEEL FASTENERS TO PREVENT THREAD DAMAGE AND GALLING

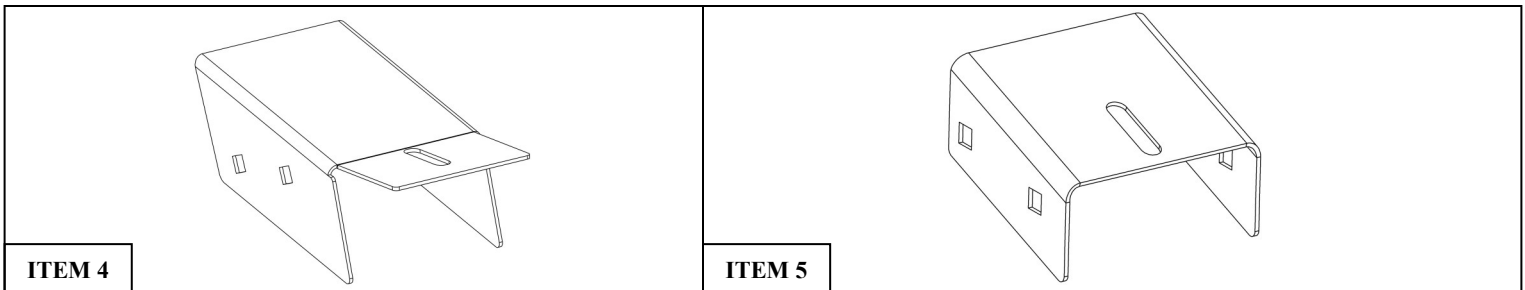
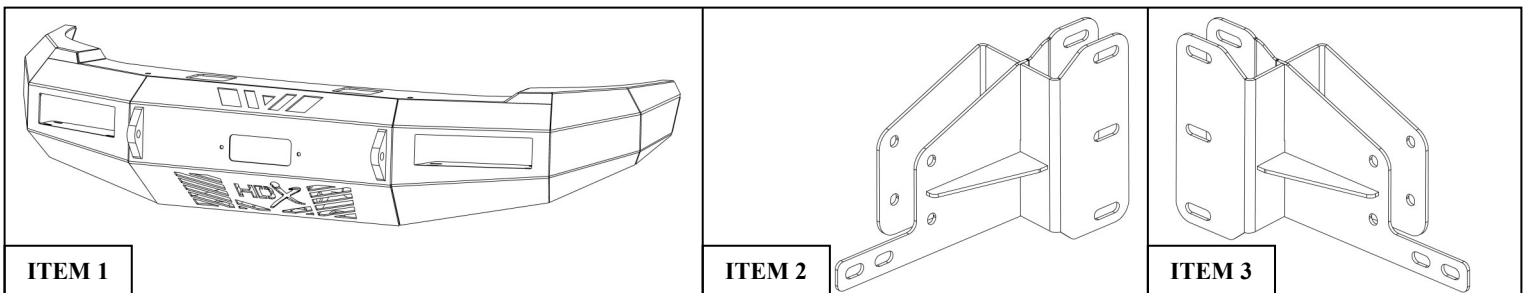

PROCEDURE

1. Remove contents from box, verify if all parts listed are present and free from damage. Carefully read and understand all instructions before attempting installation.
Failure to identify damage before installation could lead to a rejection of any claim.

2. Separate metric and standard hardware. **Note:** Standard hardware has three hashes on the heads and metric hardware is labeled as class 8.8. See **Figure 1**.

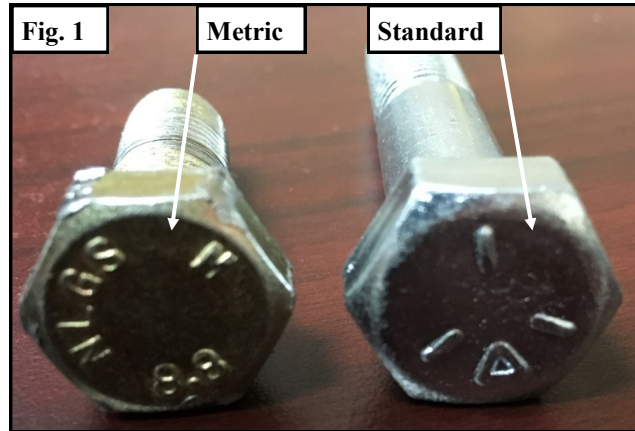

3. Remove factory bolt plates and the indicated brackets from each side of the vehicle. See **Figures 2 & 3**. **Note 1:** Factory bolt plates and brackets will not be reused. **Note 2:** If vehicle is a diesel model, the intercooler must be dropped in order to remove bumper. Go to **Diesel Applications section Pg. 3**.
4. Remove factory bumper.

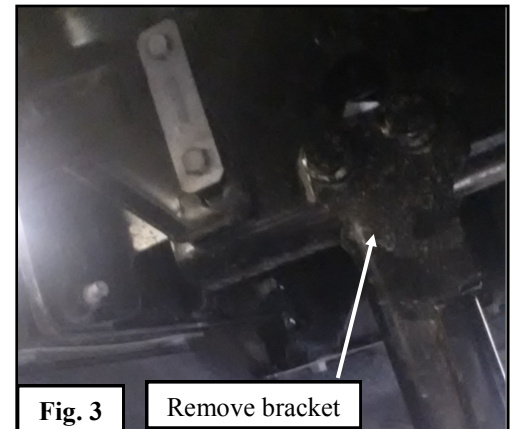
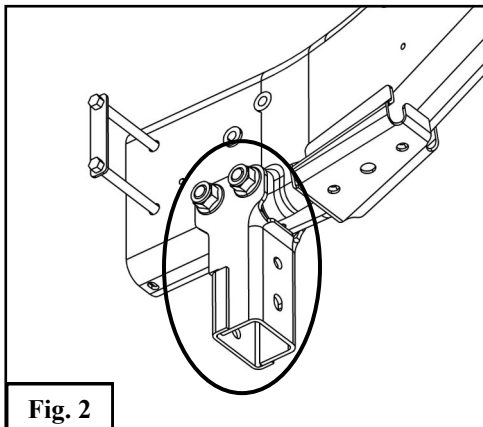

Diesel Applications Bumper Removal Instructions

- A. Remove valence from vehicle by removing factory clips and bolts. See **Figures 4 - 9**.
- B. Remove plastic cover from intercooler by removing factory bolts and plastic clips. See **Figures 10 - 13**.
- C. Loosen the hose clamps on both sides and slide back to remove hose from intercooler. See **Figures 14**.
- D. Remove factory bolts attaching intercooler bracket to vehicle. Drop intercooler. See **Figures 15**.

Bumper Removal Instructions (Diesel Applications)

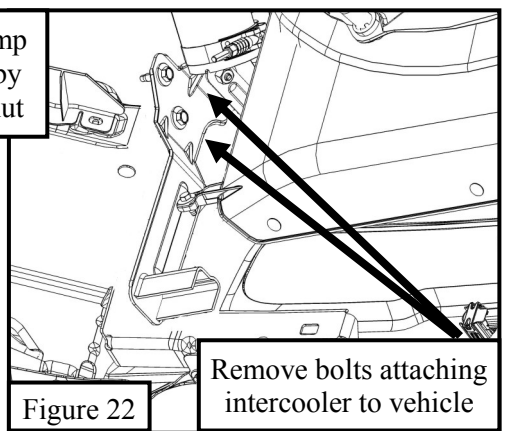
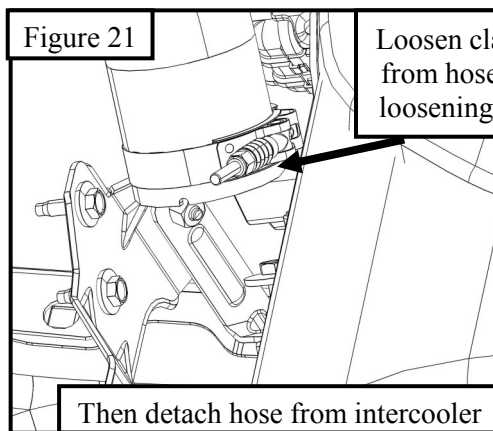
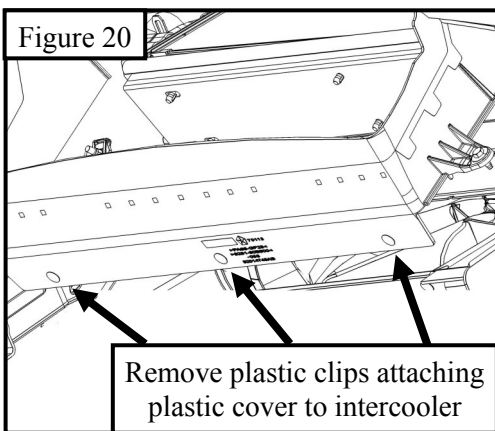
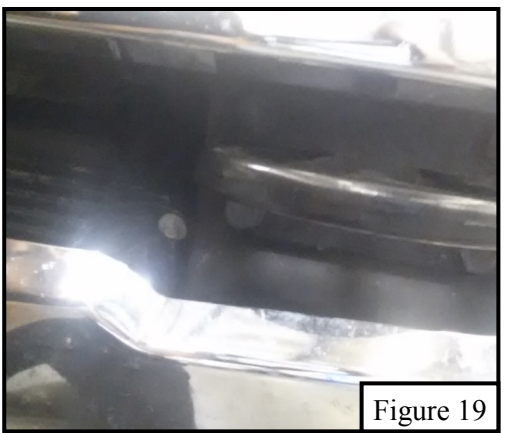
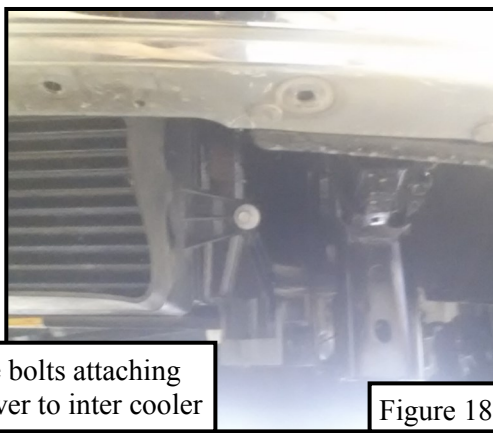
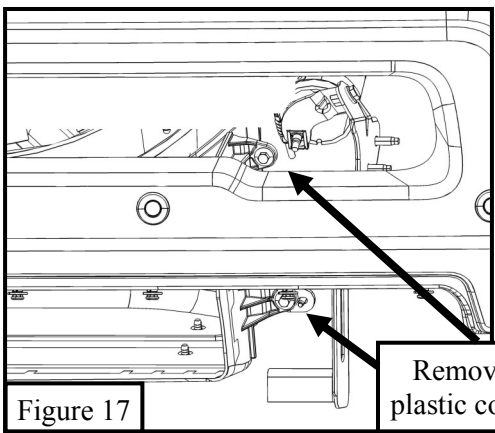
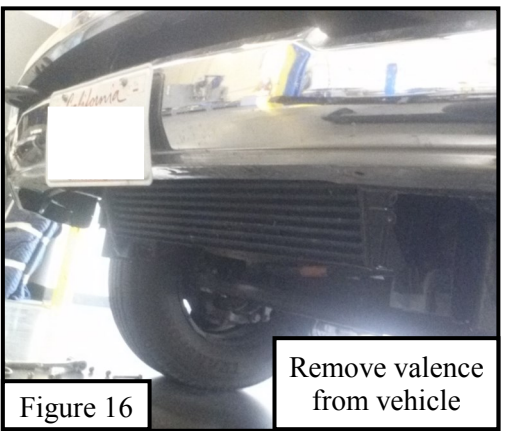
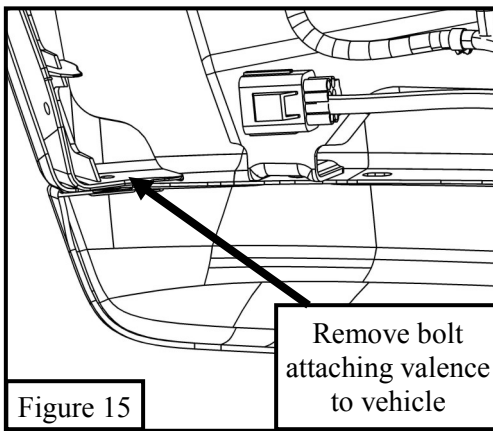
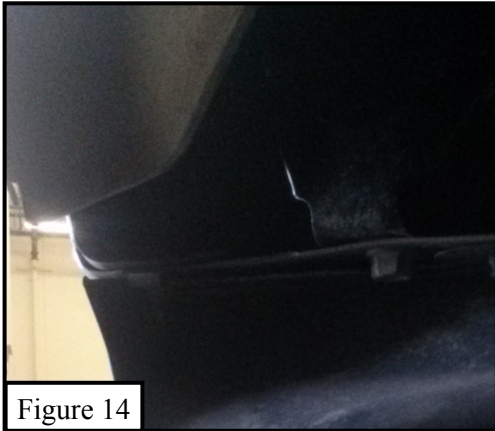
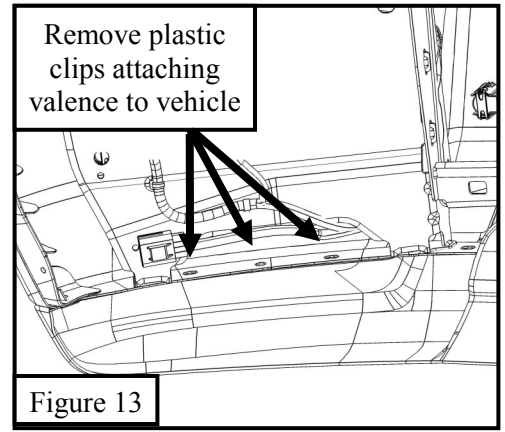
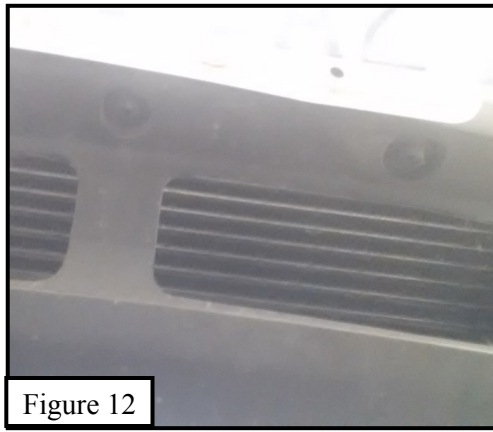
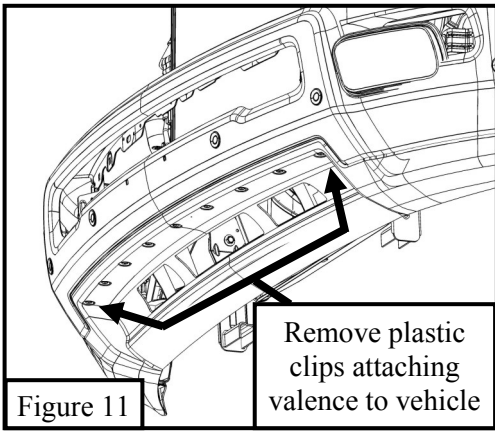

5. Loosely install mounting brackets (2 & 3) using M12 and 1/2" hardware. **Note:** Driver side bracket shown. See **Figure 16**.
6. Loosely install inner and outer lighting brackets (4 & 5) using 1/4" hardware. **Note:** Install lights with manufacturer hardware. See **Figures 17 & 18**.

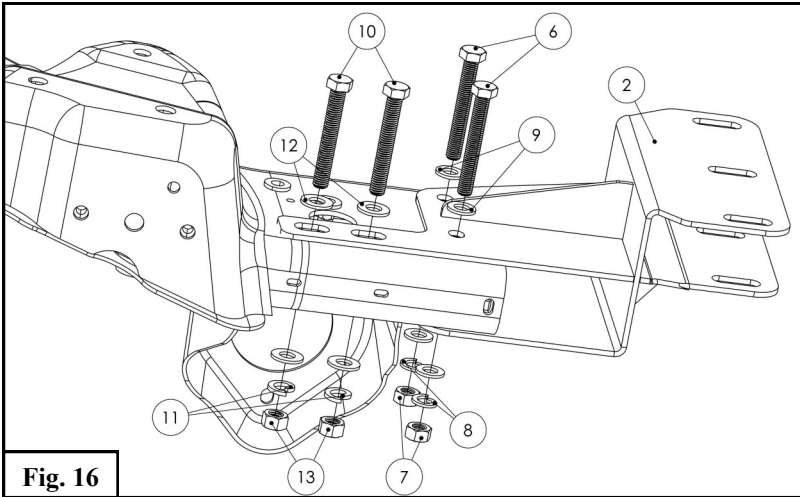

Fig. 16

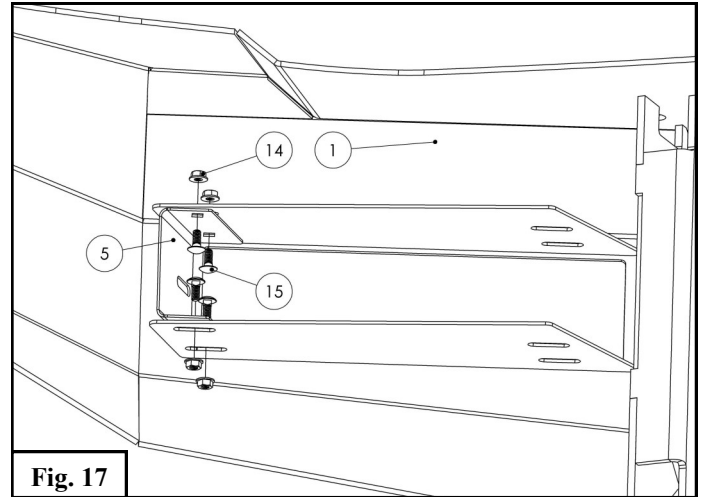

Fig. 17

NOTE : IF INSTALLING A WINCH, DO SO BEFORE INSTALLING BUMPER TO VEHICLE. Install winch per winch manufacturer instructions.

7. Loosely Install bumper assembly (1) using 1/2" hardware. **Note:** Driver side bracket shown.
8. Align and adjust previously installed brackets and bumper to desired fit. Torque hardware: 1/4" to 8 ft-lbs, 1/2" to 57 ft-lbs, and M12 to 50-55 ft-lbs. See **Figure 19**.

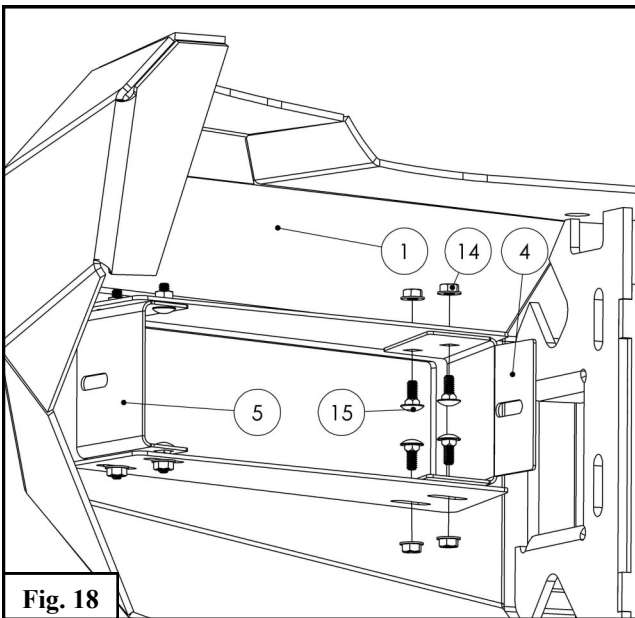

Fig. 18

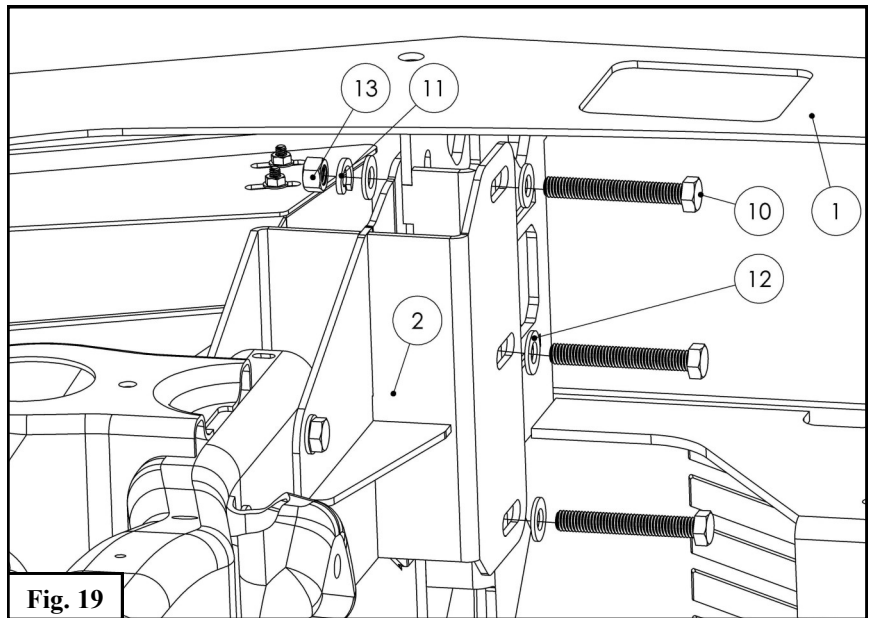

Fig. 19

INSTALLATION COMPLETED



CARE INSTRUCTIONS REGULAR WAXING IS RECOMMENDED. DO NOT USE ANY TYPE OF POLISH OR WAX THAT MAY CONTAIN ABRASIVES

- STAINLESS STEEL PRODUCTS CAN BE CLEANED WITH MILD SOAP AND WATER. STAINLESS STEEL POLISH SHOULD BE USED TO POLISH SMALL SCRATCHES.
- GLOSS BLACK FINISHES SHOULD BE CLEANED WITH MILD SOAP AND WATER

WESTIN

Westin Automotive Products, Inc.
320 W. Covina Blvd
San Dimas, Ca. 91773

Thank you for choosing Westin products
for additional installation assistance please call
Customer Service (800) 793-7846
www.westinautomotive.com

Westin

SIGNATURE OF QUALITY

AUTOMOTIVE PRODUCTS, INC.



WARNING



Failure to follow these instructions could lead to death, personal injury, and / or property damage.

FASTENERS:

All Westin supplied fasteners must be utilized and installed in accordance with the installation instructions and apply torque to the specifications as defined. **DOUBLE CHECK ALL FASTENERS BEFORE INITIAL USE, AND PERIODICALLY IN THE FUTURE TO ENSURE PROPER FUNCTION AND SAFETY.**

DRILLING:

Most Westin products do not require drilling for installation. If drilling is defined as required, use caution when drilling a vehicle. **FAILURE TO REVIEW AN AREA TO BE DRILLED MAY RESULT IN PERSONAL INJURY AND/OR INJURY TO OTHERS AS WELL AS VEHICLE DAMAGE.**

EYE PROTECTION:

ALWAYS WEAR SAFETY GLASSES OR GOGGLES DURING THE INSTALLATION PROCESS TO AVOID PERSONAL INJURY.

MAXIMUM TOWING/CARRYING CAPACITY:

The Westin Receiver Hitches will have a visible tow rating label affixed directly on the product. User should never exceed the vehicle manufacturers maximum tow and weight rating regardless of the capacity of the hitch. **FAILURE TO FOLLOW THESE GUIDELINES WILL VOID THE WESTIN WARRANTY AND MAY RESULT IN PERSONAL INJURY AND/OR INJURY TO OTHERS AS WELL AS VEHICLE DAMAGE.**

WESTIN

Westin Automotive Products, Inc.
320 W. Covina Blvd
San Dimas, Ca. 91773

Thank you for choosing Westin products
for additional installation assistance please call
Customer Service (800) 793-7846
www.westinautomotive.com