



INSTALLATION INSTRUCTIONS

HDX DROP STEP

APPLICATION:

1999-2016 Ford F250 / F350 / F450 / F550 - Super Cab / Super Crew

AUTOMOTIVE PRODUCTS,

PART NUMBER:

56-11315, 56-11335

| CONTENT | | | |
|---------|----------|---|---------------|
| ITEM | QUANTITY | DESCRIPTION | TOOLS NEEDED |
| 1 | 2 | STEP BAR ASSEMBLY | RATCHET |
| 2 | 4 | MOUNTING BRACKET | TORQUE WRENCH |
| 3 | 1 | DRIVER SIDE CENTER MOUNTING BRACKET | 13MM SOCKET |
| 4 | 1 | PASSENGER SIDE CENTER MOUNTING BRACKET | ALLEN WRENCH |
| 5 | 2 | FRONT SPACER PLATE | SOCKET EXT. |
| 6 | 10 | M8 EXTRUDED U-NUT (YELLOW ZINC) | |
| 7 | 12 | M8 HEX NUT (BLACK ZINC) | |
| 8 | 12 | M8 BUTTON HEAD CAP SCREW (BLACK ZINC) | |
| 9 | 12 | M8 SPLIT LOCK WASHER (BLACK ZINC) | |
| 10 | 24 | M8 FLAT WASHER (BLACK ZINC) | |
| 11 | 12 | SHORT M8 HEX HEAD CAP SCREW (YELLOW ZINC) | |
| 12 | 10 | LONG M8 HEX HEAD CAP SCREW (YELLOW ZINC) | |
| 13 | 22 | M8 SPLIT LOCK WASHER (YELLOW ZINC) | |
| 14 | 22 | M8 FLAT WASHER (YELLOW ZINC) | |

ANTI-SEIZE LUBRICANT MUST BE USED ON ALL STAINLESS STEEL FASTENERS TO PREVENT THREAD DAMAGE AND GALLING

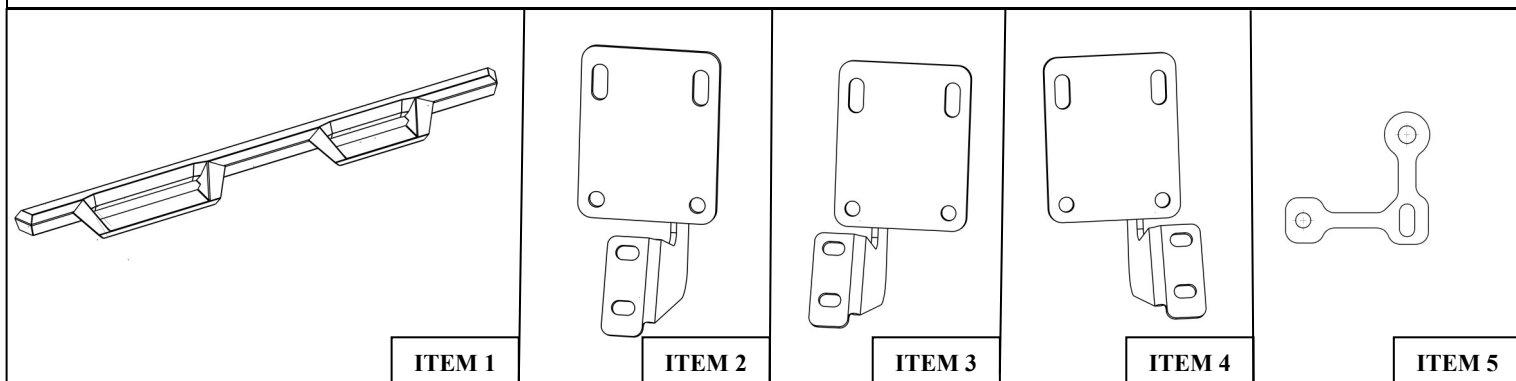

PROCEDURE

1. Remove contents from box, verify if all parts listed are present and free from damage.
Carefully read and understand all instructions before attempting installation.
Failure to identify damage before installation could lead to a rejection of any claim.



Westin Automotive Products, Inc.
320 W. Covina Blvd
San Dimas, Ca. 91773

Thank you for choosing Westin products
for additional installation assistance please call
Customer Service (800) 793-7846

www.westinautomotive.com

2. Start installation on driver's side. On the rocker panel find locations with open holes and insert in the top open holes (2) M8 nut clips (Item 6). **NOTE: ON SOME VEHICLES THE MOUNTING HOLES DO NOT LINE UP FROM THE FACTORY IF THIS IS THE CASE DRILL OUT THE HOLES USING A 7/16" DRILL BIT**
3. Then loosely install M8 hardware to previously installed Nut Clip; (2) M8 hex head bolts, (2) M8 flat washers, (2) M8 split lock washers. For installing to bottom open holes of the rocker panel, loosely install, (2) M8 button head bolts, (4) M8 flat washers, (2) M8 split lock washers, (2) M8 hex nuts. Repeat the same procedure for all other mounting locations. **See Figure 1.**
4. Note: For 2010– up model years place (1) front mounting bracket spacer (Item 5) in between the rocker panel and the front mounting bracket before installing. **See Figure 2**

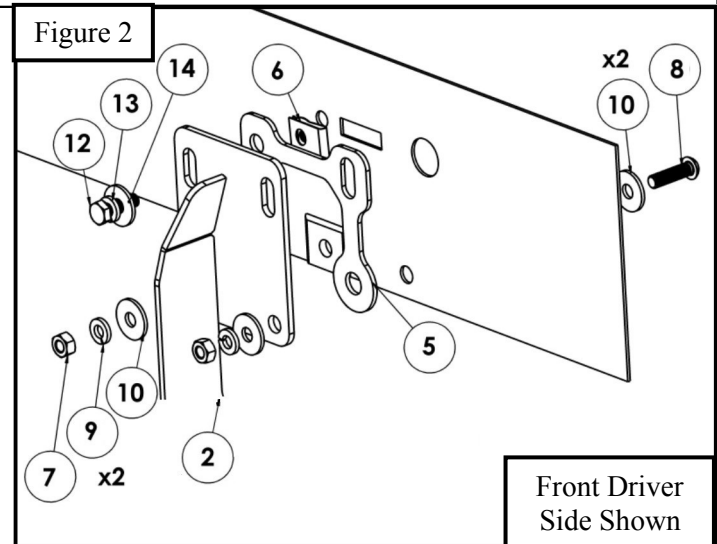
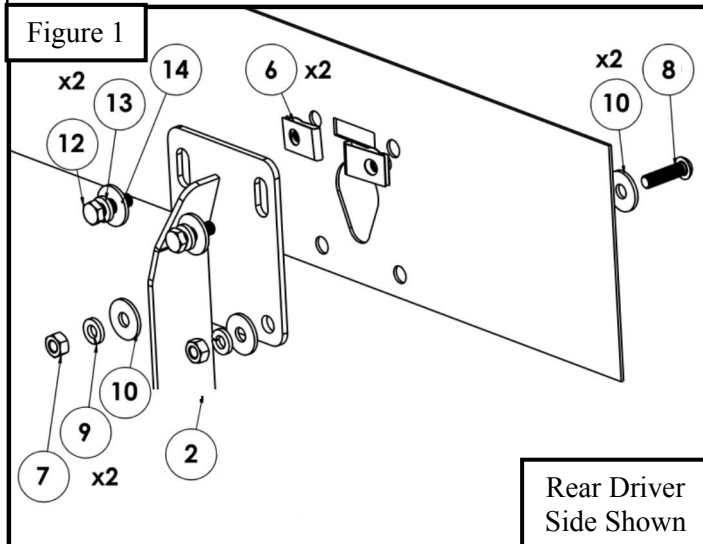

5. Tilt Board at angle to insert brackets into center mounting locations, item 3 for Driver Side and item 4 for Passenger Side. **See Figure 3**
6. For Step Board installation to the previously installed mounting brackets use the supplied M8 hardware. **See Figure 4.**
7. Align step bar and brackets to desired positioning then torque and tighten all: M8 hardware to 20 ft-lbs.

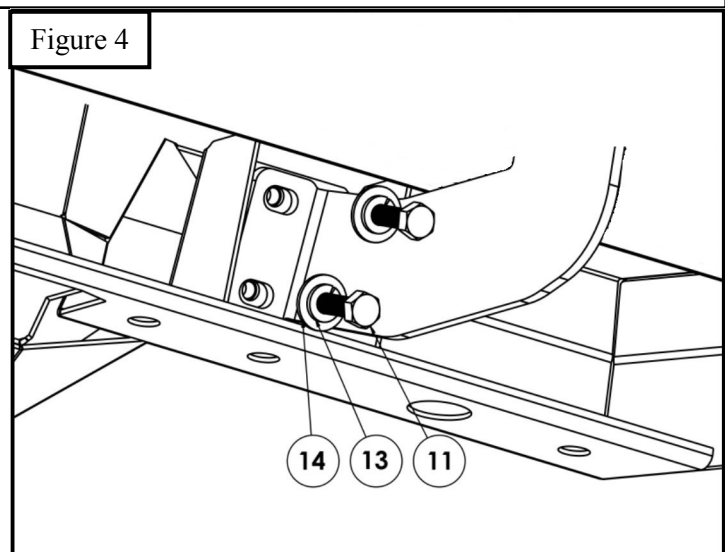
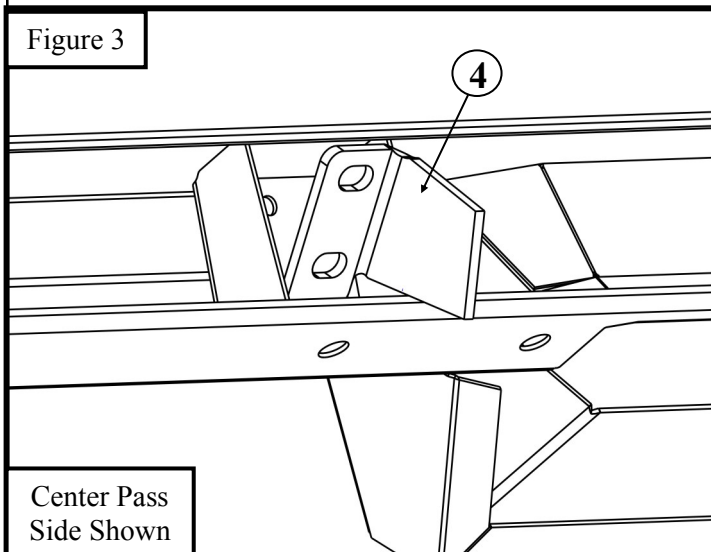

Westin Automotive Products, Inc.
320 W. Covina Blvd
San Dimas, Ca. 91773

8. Below are Figures representing the orientation and positioning of the brackets for Crew Cab and Ext. Cab trucks.

See Figures below

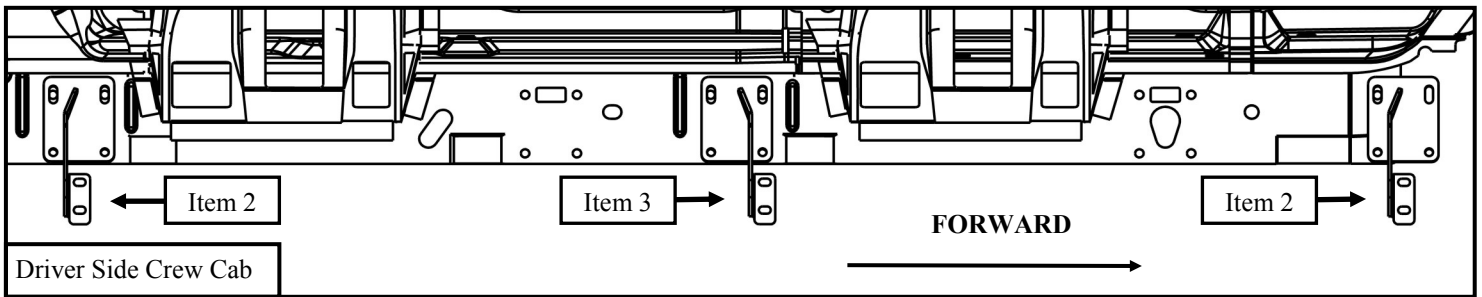
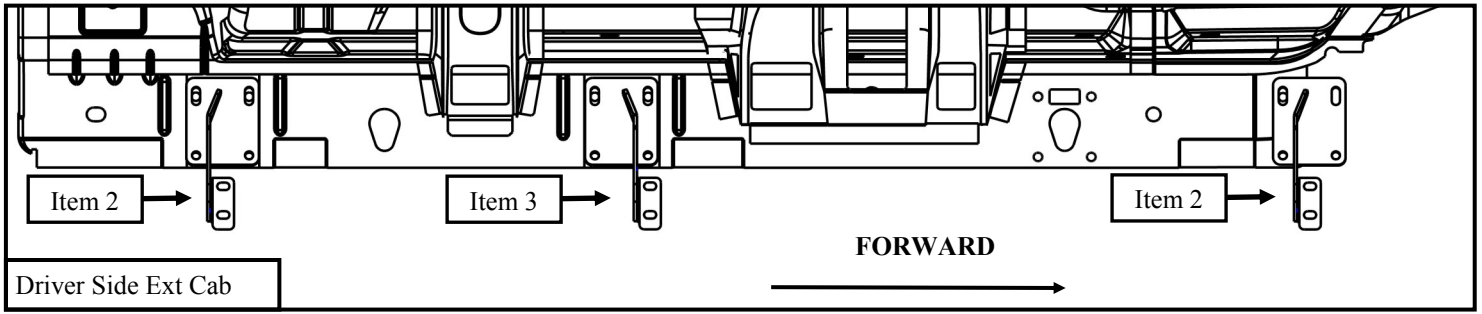

Westin Automotive Products, Inc.
320 W. Covina Blvd
San Dimas, Ca. 91773

Thank you for choosing Westin products
for additional installation assistance please call
Customer Service (800) 793-7846

INSTALLATION COMPLETED



**SUPER CREW
SHOWN**

INSTALLATION COMPLETED



**SUPERCAB
SHOWN**

Care Instructions

- REGULAR WAXING IS RECOMMENDED. DO NOT USE ANY TYPE OF POLISH OR WAX THAT MAY CONTAIN ABRASIVES.
- STAINLESS STEEL PRODUCTS CAN BE CLEANED WITH MILD SOAP AND WATER. STAINLESS STEEL POLISH SHOULD BE USED TO POLISH SMALL SCRATCHES.
- GLOSS BLACK FINISHES SHOULD BE CLEANED WITH MILD SOAP AND WATER.



Westin Automotive Products, Inc.
320 W. Covina Blvd
San Dimas, Ca. 91773

**Thank you for choosing Westin products
for additional installation assistance please call
Customer Service (800) 793-7846
www.westinautomotive.com**

Westin

SIGNATURE OF QUALITY

AUTOMOTIVE PRODUCTS, INC.



WARNING



Failure to follow these instructions could lead to death, personal injury, and / or property damage.

FASTENERS:

All Westin supplied fasteners must be utilized and installed in accordance with the installation instructions and apply torque to the specifications as defined. **DOUBLE CHECK ALL FASTENERS BEFORE INITIAL USE, AND PERIODICALLY IN THE FUTURE TO ENSURE PROPER FUNCTION AND SAFETY.**

DRILLING:

Most Westin products do not require drilling for installation. If drilling is defined as required, use caution when drilling a vehicle. **FAILURE TO REVIEW AN AREA TO BE DRILLED MAY RESULT IN PERSONAL INJURY AND/OR INJURY TO OTHERS AS WELL AS VEHICLE DAMAGE.**

EYE PROTECTION:

ALWAYS WEAR SAFETY GLASSES OR GOGGLES DURING THE INSTALLATION PROCESS TO AVOID PERSONAL INJURY.

MAXIMUM TOWING/CARRYING CAPACITY:

The Westin Receiver Hitches will have a visible tow rating label affixed directly on the product. User should never exceed the vehicle manufacturers maximum tow and weight rating regardless of the capacity of the hitch. **FAILURE TO FOLLOW THESE GUIDELINES WILL VOID THE WESTIN WARRANTY AND MAY RESULT IN PERSONAL INJURY AND/OR INJURY TO OTHERS AS WELL AS VEHICLE DAMAGE.**

Westin
SIGNATURE OF QUALITY

Westin Automotive Products, Inc.
320 W. Covina Blvd
San Dimas, Ca. 91773