

VOLANT AIR INTAKE SYSTEMS

TOYOTA 99-02 24 VALVE TACOMA

PART NO.: 18634

INSTALLATION INSTRUCTIONS

OFF ROAD USE ONLY

WWW.VOLANTPERFORMANCE.COM

TECH SUPPORT: (909) 476-7225

REMOVE THE 5/8" STOCK HOSE FROM THE VALVE COVER AND REPLACE IT WITH THE 5/8" X 5' VOLANT HOSE. USE THE 5/8" STRAIGHT FITTING TO ATTACH THE REMAINING END OF THE VOLANT HOSE TO THE 5/8" STOCK HOSE. CONNECT THE OTHER END OF THE STOCK HOSE TO THE VOLANT DUCT.

TOYOTA 99-02 24 VALVE TACOMA	
1	FILTER BOX
1	FILTER BOX LID
1	VOLANT AIR DUCT
1	RAM FILTER W/CLAMP
2	#048 CLAMPS
1	3" X 2 1/2" SLEEVE
5	1/4" TRUSS HEAD SCREWS
5	1/4" RUBBER WASHERS
2	STAINLESS STEEL SCREWS
1	1/4" X 16" VOLANT BREATHER HOSE
1	5/8" X 5' VOLANT HOSE
1	5/8" STRAIGHT FITTING
1	14 1/2" TRIM W/RUBBER SPONGE
1	1" THICK "O" RING

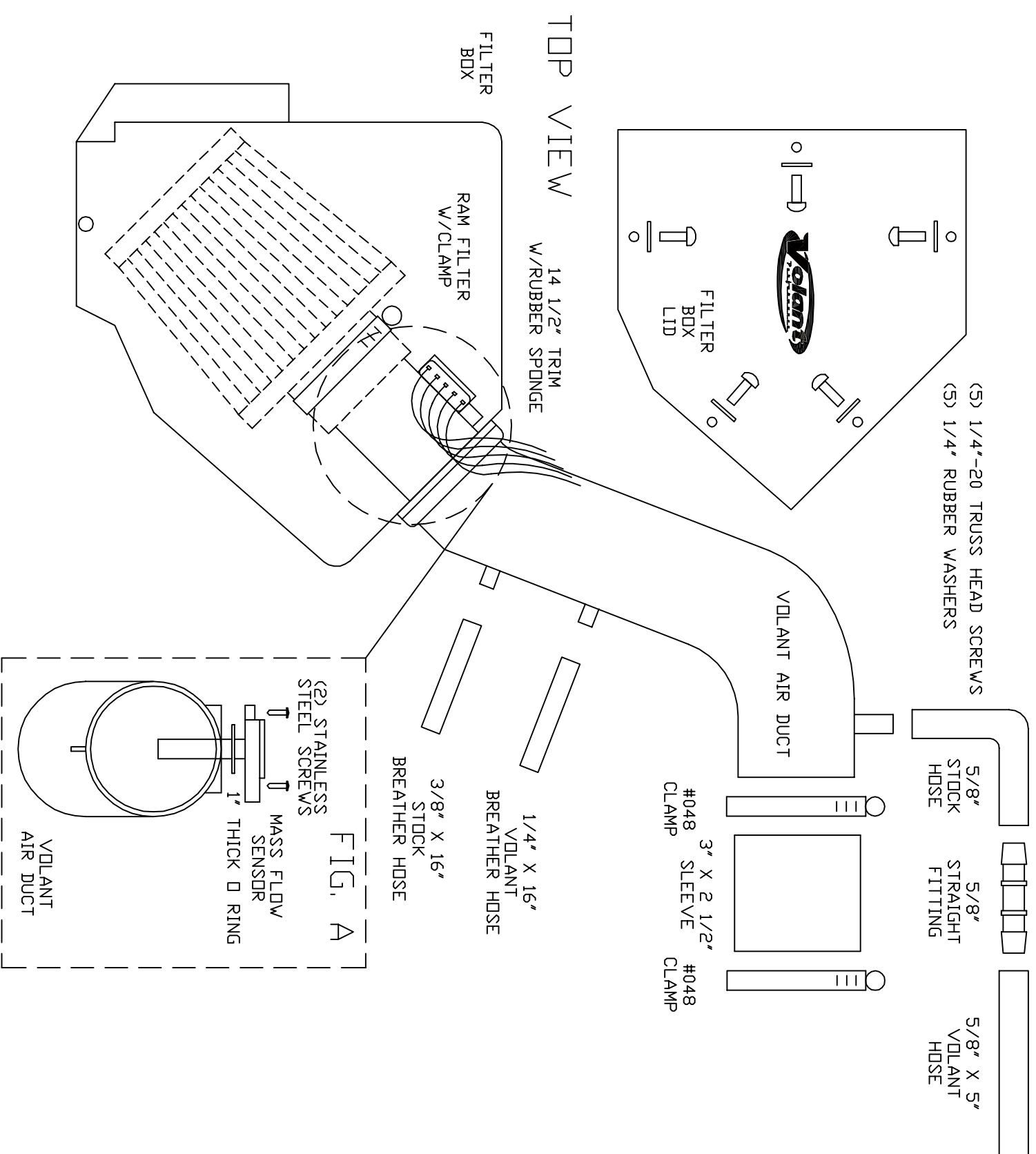
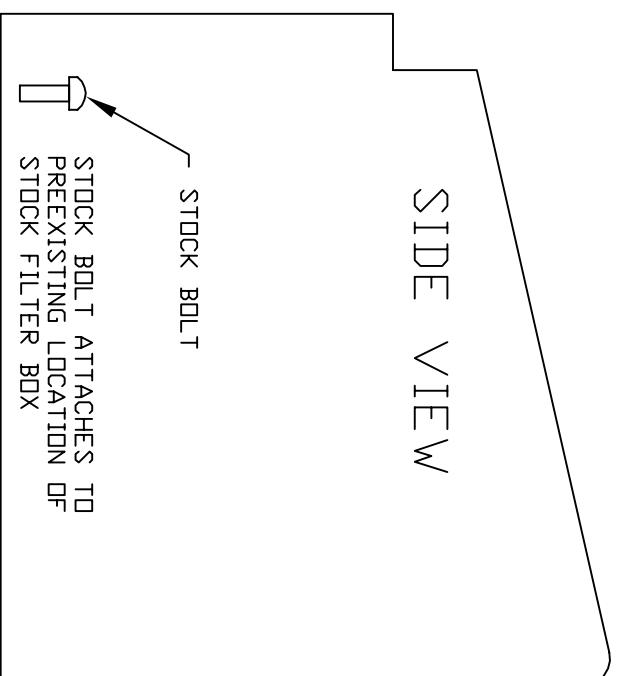



Volant Performance
 Rancho Cucamonga, CA 91730
 (909) 481-3888 Tech Support
 (909) 476-1491 Fax
 www.volant.com

READ INSTRUCTIONS THOROUGHLY BEFORE DISASSEMBLING. DO NOT SKIP ANY STEPS. ANY QUESTIONS ON A VOLANT KIT MAY BE REFERRED TO OUR TECH SUPPORT LINE AT (909) 481-3888 OR VISIT OUR WEBSITE AT WWW.VOLANT.COM

INSTALLATION INSTRUCTIONS PART NO. 18634

Installation Instructions:

1. Disconnect the negative battery cable.
2. Remove the MAF sensor from the factory air duct.
3. Remove the three bolts holding the air box into place.
4. Remove the breather hoses from the factory air duct.
5. Remove the factory intake system.
6. Place the volant box into factory position
7. Press the 14.5 trim around the hole were the duct slides through.
8. Place the MAF sensor inside of the volant air box.
9. Slide the volant air duct through the hole and attach the MAF sensor with the hardware provided.
10. Attach the duct to the throttle using the sleeve and clamps provided.
11. Attach the breather hoses to the volant air duct.
12. Re attach the negative battery cable.

WARNING: OVER TIGHTENING HARDWARE MAY ALTAR THE INTEGRITY OF THE VOLANT AIR INTAKE SYSTEM.

BEFORE ROAD TESTING

1. Start engine, leaving the transmission in park and securing the parking brake.
2. Make sure to look and listen for any unusual noises or air leaks. Repair problems if needed.
3. Once completed it will be necessary to check periodically for realignment and tightening of all connections.
4. Once all tests are completed, enjoy the performance of your new Volant Air Intake System.

CARE AND CLEANING

Check the cotton reusable filter periodically and remove any excessive dirt build-up by tapping the filter on the ground and brushing off the loosened dirt. Clean the filter by using Volant's Filter Recharger Kit. Volant's Filter Recharger Kit is designed to restore original air flow. Re-oil every 10,000 miles without cleaning to improve filtering in sand and dirt. Clean only when dirt is very excessive or 50,000 miles.

RECOMMENDED SERVICE PARTS

RECOMMENDED SERVICE PARTS	PART NO.
REPLACEMENT FILTER	5129
PREFILTER	51901
CLEANING KIT	5100

APPLICATION GUIDE

MY	MAKE	MODEL	ENG.
99-03	TOYOTA	TUNDRA	3.4L
99-03	TOYOTA	4 RUNNER	3.4L
99-03	TOYOTA	S-RUNNER	3.4L
99-04	TOYOTA	TACOMA	3.4L

INSTALL

