

## ⚠️ IMPORTANT

### READ BEFORE YOU BEGIN INSTALLATION

**IT IS CRITICAL FOR YOUR SAFETY THAT YOU CAREFULLY READ AND FOLLOW THE SAFETY CAUTIONS AND INSTALLATION INSTRUCTIONS BOTH PRIOR TO AND DURING INSTALLATION.**

#### USER SAFETY CAUTION

During installation, be mindful of the potential for sharp edges on the product or vehicle. Taking proper safety precautions helps ensure a safe and smooth installation process.

**Always wear protective gloves and handle components with care to reduce the risk of injury.**



#### TEMPERATURE SURFACE CAUTION

During high temperatures or extended sun exposure, surfaces of this product may become hot to the touch, posing a risk of burns or injury. Use caution when handling the product in hot weather and allow time for it to cool before contact.

**Always check surface temperature before use to ensure safe handling conditions.**



#### FASTENER TORQUE CAUTION

All fasteners must be tightened to the specified torque values provided in the installation instructions to ensure proper fit and safe operation of the tonneau cover. Under- or over-tightening can lead to product failure, potential damage to your vehicle, injury, or safety hazards while driving.

**Always use a calibrated torque wrench and follow the specifications in the installation instructions.**

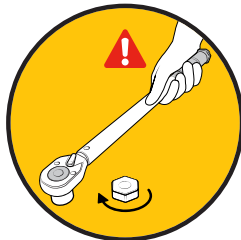

#### PINCH POINT SAFETY CAUTION

This tonneau cover may create pinch points when closing or operating near solid surfaces such as the truck bed rails or tailgate. To prevent injury, keep hands, fingers, and other body parts clear of moving parts during operation.

**Always operate the cover slowly and with caution to ensure safe and proper use.**



## **! IMPORTANT**

### **READ BEFORE YOU BEGIN INSTALLATION**

**IT IS CRITICAL FOR YOUR SAFETY THAT YOU CAREFULLY READ AND FOLLOW THE SAFETY CAUTIONS AND INSTALLATION INSTRUCTIONS BOTH PRIOR TO AND DURING INSTALLATION.**

#### **ENTRAPMENT SAFETY WARNING**

This tonneau cover does not feature a manual release mechanism from inside the truck bed. To prevent the risk of entrapment, never allow anyone to be inside the bed of the truck when the cover is closed.

**Always ensure the area is clear before closing the cover, and keep the cover securely latched when not in use to avoid accidental closure.**

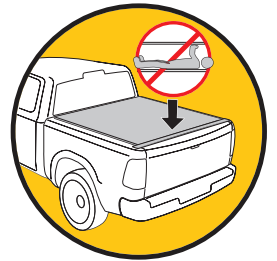

#### **CARGO TRANSPORT WARNING**

Do not attempt to close the tonneau cover over cargo that is taller than the depth of the truck bed.

Never force the cover to close improperly.

**Forcing the cover can:**

- Prevent the cover from lying flat and latching securely.
- Damage the cover's hinge and cause the cover to kink.
- Damage the rear tail panel and cause it to become detached.

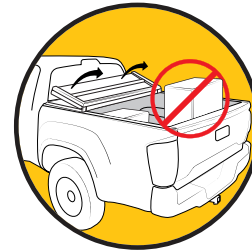

# INSTALLATION SHEET

**Any damaged or missing parts?**

Parts will be shipped to you directly.

Call 866-900-8800 Mon - Fri 8:00 am - 5:00 pm CST  
or email [info@undercoverinfo.com](mailto:info@undercoverinfo.com)

## TOOLS REQUIRED

- Scissors or utility knife
- Isopropyl alcohol
- 1/2" Wrench or socket
- Phillips screwdriver
- 5/8" Drill bit & drill

**NOTE:** It is important that all areas where the bed cover mounts are clean and free of debris prior to installing.

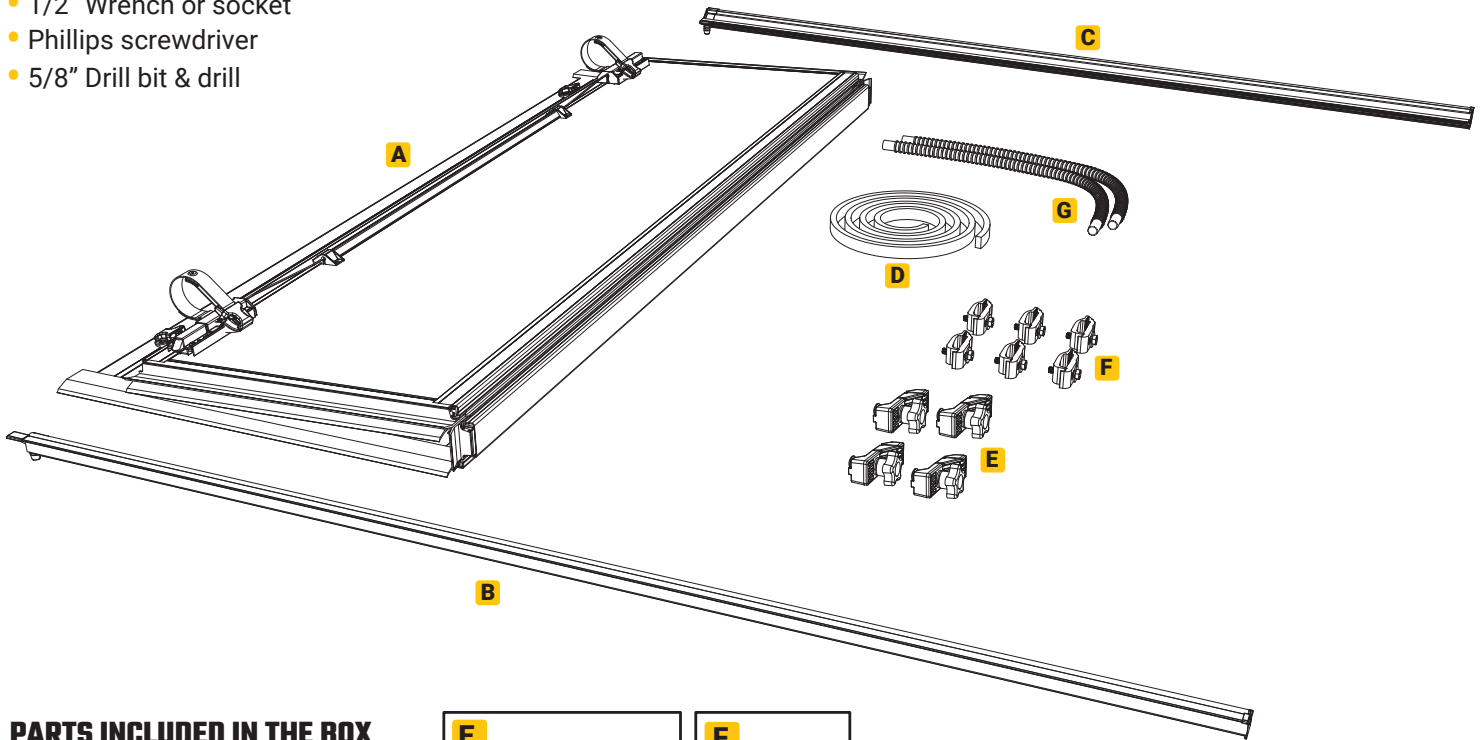

## PARTS INCLUDED IN THE BOX

- A** 1x Hard fold cover
- B** 1x Driver side rail
- C** 1x Passenger side rail
- D** 1x Bulkhead seal
- E** 4x Cover retainer clamps
- F** 6x Clamps
- G** 2x Drain tubes

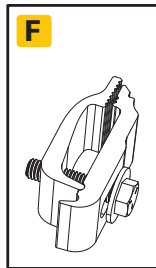
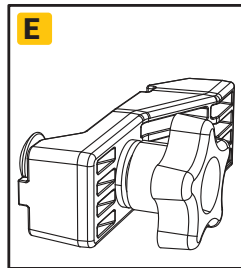

**1** **Installing Seal:** Install bulkhead seal (D) included with cover (A) by cleaning the top of the bulkhead with soap and water to remove dirt and debris. Clean the area with isopropyl alcohol to remove wax or grease and to evaporate any remaining water. Allow the surface to dry. Peel the backing and adhere the seal from one bulkhead edge to the other. Remove any excess with scissors or a utility knife. Apply pressure evenly to the entire seal to ensure proper adhesion. If the truck has a drop-in bedliner, no seal will be needed.

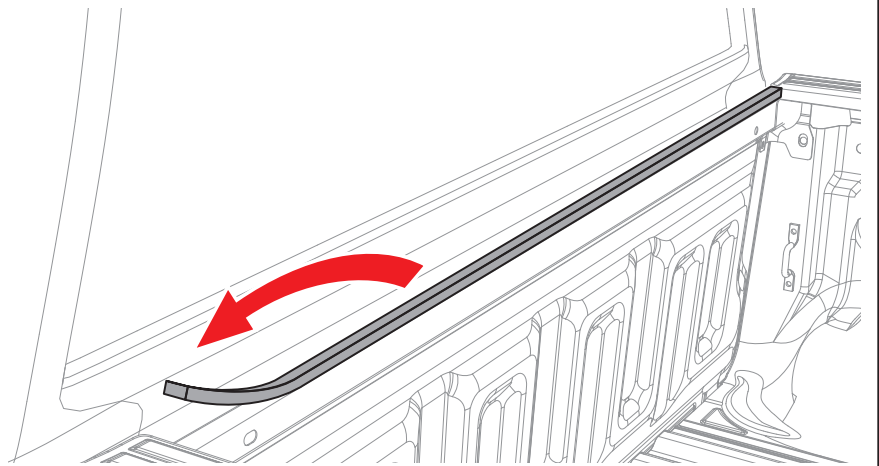

**2** Slide the clamp (F) up to capture the truck bed rail and the cover rail.

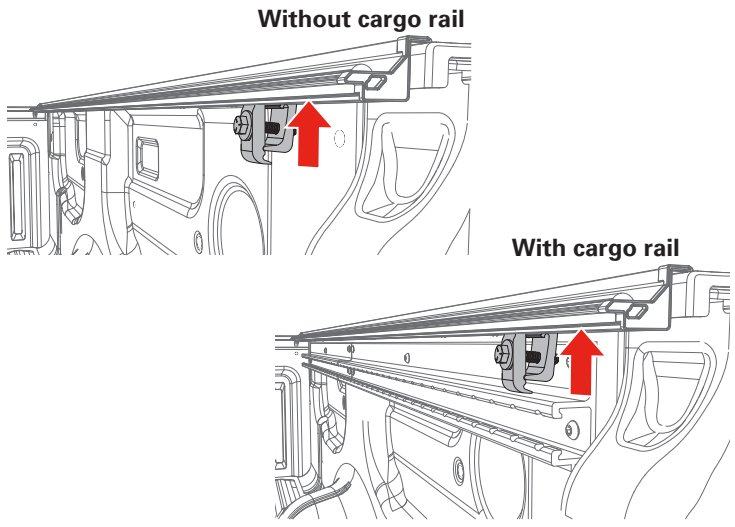

**3** Slide three front halves of the clamp (F) into the rail in the tapered slot. Position the rear front half of the clamp (F) as close to the tailgate as possible. It should be less than 12". Place the second front half of the clamp (F) near the center of the rail. Position the third front half of the clamp (F) as close to the front of the rail as possible. It should be less than 12" from the front.

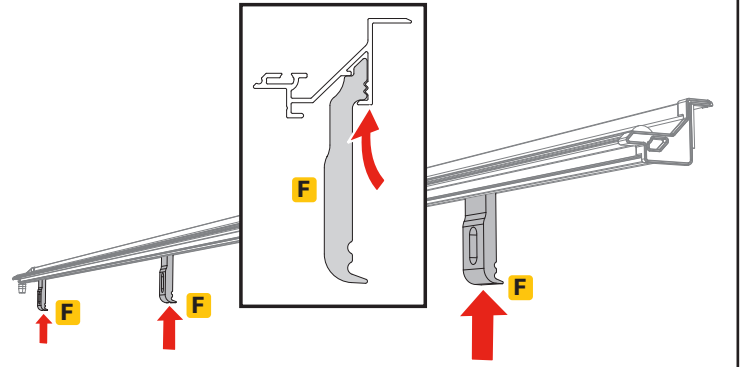

**4** For the best (A) fit, the side rails (B & C) should be level with the truck bed sheet metal and not angled up or down. Insert the backside of the clamp as high as possible and tighten clamp. Tighten all clamps to 10 ft/lbs of torque with a 1/2" wrench or socket. **Caution: Do NOT overtighten!**

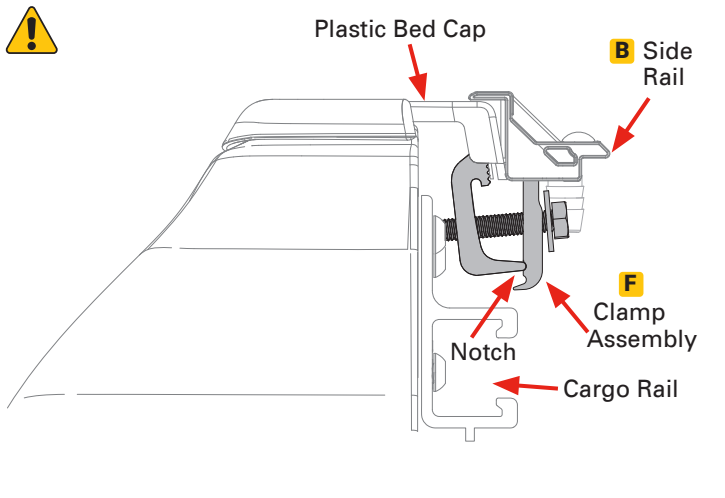

**5** Attach the drain tubes (G) to the front of the side rails (B & C).

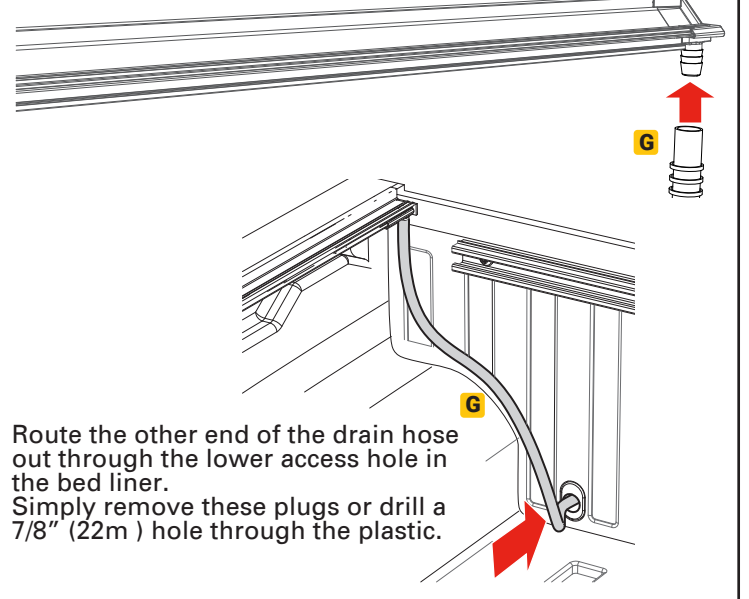

Route the other end of the drain hose out through the lower access hole in the bed liner. Simply remove these plugs or drill a 7/8" (22mm) hole through the plastic.

**6** Align the driver side rail (B) with the drain tube fitting going towards the cab of the truck and pushed up against the bulkhead. Make sure you check the position of the three clamps (F) where you positioned them in steps 3 & 4. Tighten the bolts to 10 ft/lbs of torque with a 1/2" wrench or socket.

**CAUTION: Do NOT overtighten.** Repeat on passenger side rail (C).

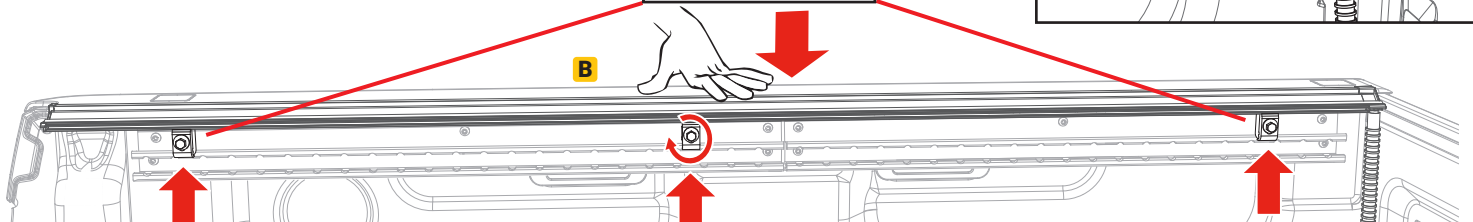
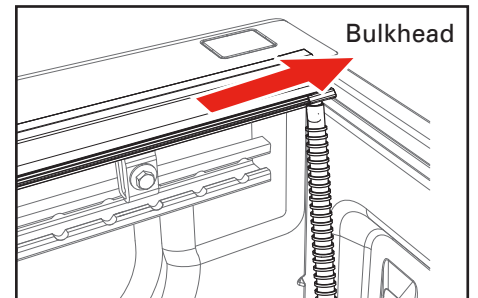
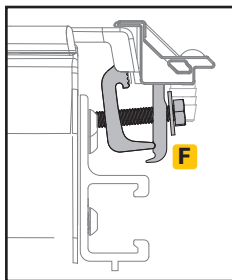

**NOTE:** If the rails are leaning down, have one person stand on the outside of the bed and slightly roll the rails upward while another person slowly snugs the clamps up. If the clamps are tightened too quickly or overtightened, it will cause the rails to lean down.

**7** Before placing the cover (A) onto the vehicle, slide four front cover retainer clamps (E) into the track on the underside of the cover (A) near the cab. Confirm the cover retainer clamps fit properly into the cover rail for optimum fit. Repeat on the opposite side of the cover.

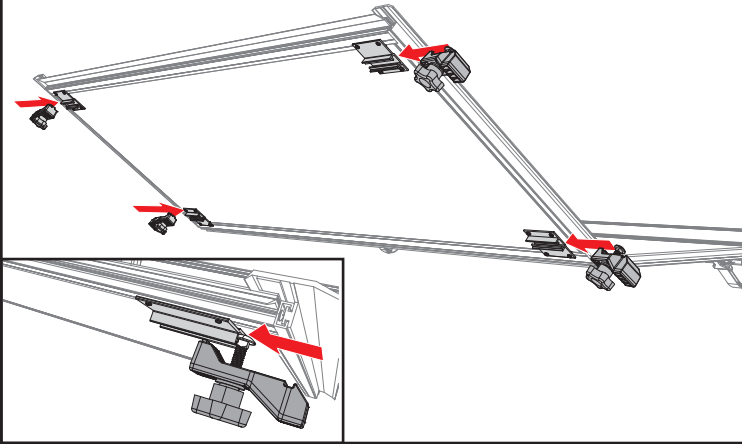

**8** Set the cover (A) in the folded position on the side rails (B & C) towards the cab of the truck. Confirm the cover is evenly spaced between the rails.

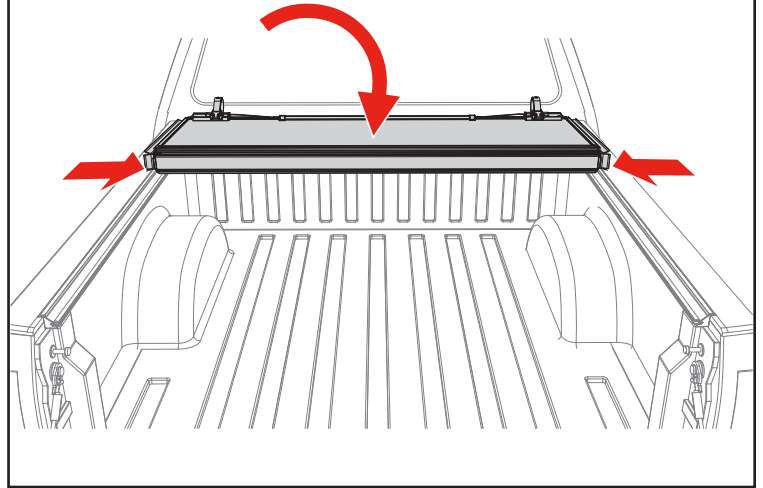

**9** Confirm the retainer clamps (E) are positioned around the side rails (B & C) correctly as shown below. Tighten the retainer clamps by turning them clockwise until the lock washer is secure.

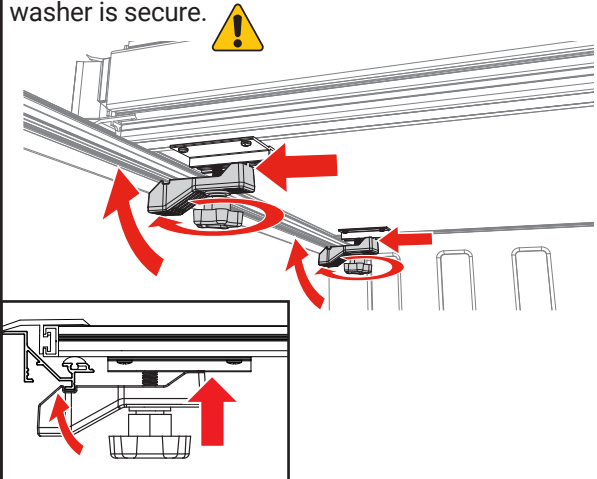

**10** Unfold the cover (A) towards the tailgate. Then confirm each panel is centered side to side and front to back on the truck bed. If adjustments are needed, loosen the cover retainer clamps (E) and shift the cover (A) until positioned correctly. Retighten the cover retainer clamps once the desired fitment is reached. *If adjustments to the slam latch are needed, see the directions on the next page.*

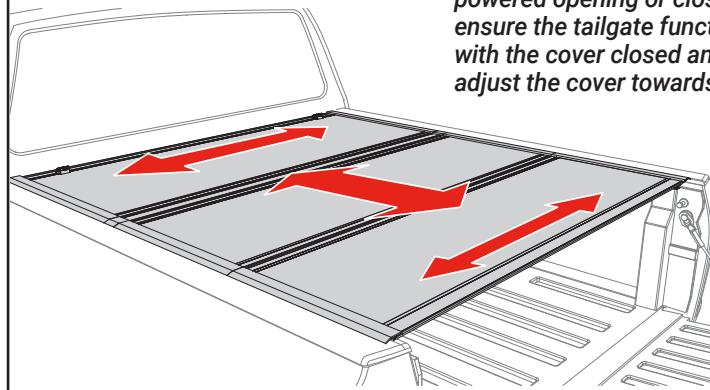

**Power Tailgates:** If your truck has a powered opening or closing tailgate ensure the tailgate functions properly with the cover closed and if needed adjust the cover towards the truck cab.

**11** The rear edge of the cover (A) and tailgate seal should rest on top of the tailgate. **You are ready to drive with your cover in the closed position.**



**OPENING COVER:** Lower the tailgate and pull the cable on either side. While pulling on the cable lift the panel up and towards the cab.

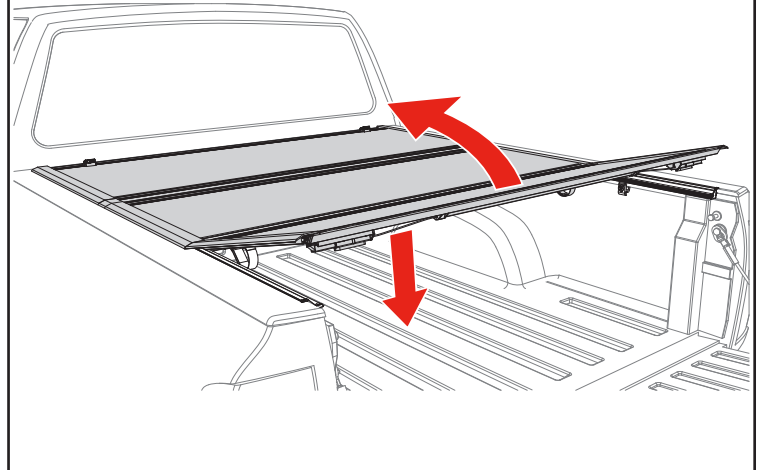

**FOLDED UP POSITION:** To drive with the cover (A) in the folded up position, use the straps and buckles provided with the cover. Attach the buckle at the bulkhead, then pull the strap to take up the slack and secure the cover. ⚠

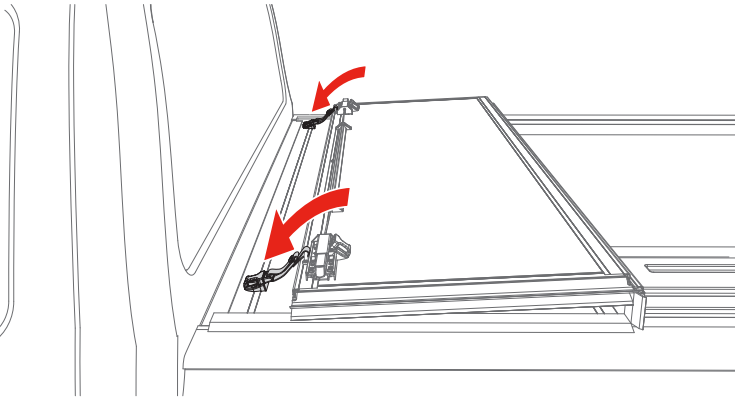

**CLOSING COVER:** To drive with the cover (A) closed, unhook the buckles and straps from the bulkhead. Stow the straps using the clips on the underside of the folded cover. Fold all panels towards the tailgate making sure that all latches are engaged.

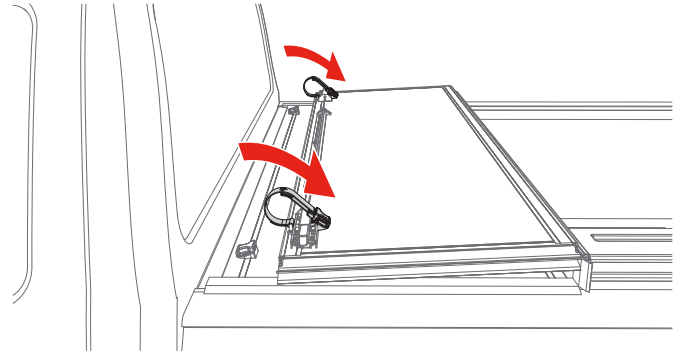

### ADJUSTING SLAM LATCH

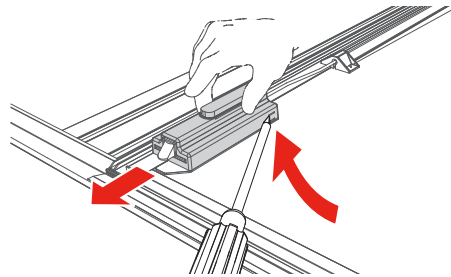

Use a screwdriver to partially pry open the tab on the latch housing. At the same time slide the housing away from the latch assembly.

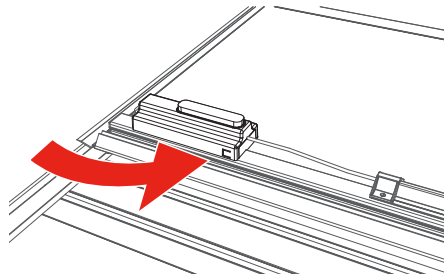

**Note:** that the tab is located on the opposite side of the housing on the passenger side of the cover.

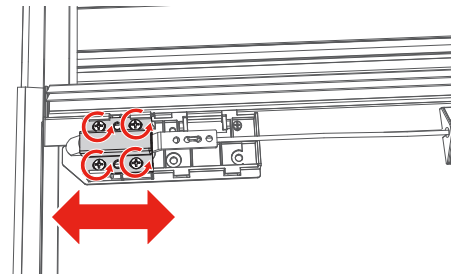

With the latch cover removed, loosen the screws and move the latch bracket to adjust. Tighten the screws. Slide the latch housing back on.

## CARE AND MAINTENANCE

The truck bed cover requires occasional cleaning with mild automotive soap and water only. Avoid using abrasive cleaners as they may dull the finish. Some chemicals and fluids such as insect repellents, oils, solvents, and lubricants could potentially damage the rubber hinges and seals and void the warranty.

### CAUTION

Always read the ingredients of any product you are using to clean your truck bed cover. Make sure that you use only products that are safe for use with rubber. Many cleaners contain chemicals that could permanently discolor or damage your hinges and seals.



Periodically check that your cover is securely attached to your truck bed and working as intended. Inspect all hardware such as clamps and front cover retainer clamps to ensure they are properly installed and working as intended. Covers that are used at high frequency or subject to rough roadways and/or heavy vibration conditions may cause the cover to require adjustment.

It is also recommended that you regularly inspect and service each panel latch. Clean away any excess dirt or grime. Ensure all latches move freely in and properly engage the side rail to provide optimal performance and security.



## SAFETY INSTRUCTIONS

- DO NOT place objects on or against cover or framework.
- DO NOT tie cargo to truck bed cover or framework.
- DO NOT operate vehicle with objects on top of the cover.
- NEVER allow children or pets to occupy the truck bed with the cover in the fully closed position.
- The cover is not airtight. Special care is required to keep cargo clean and dry.
- Truck bed covers will not prevent theft of contents inside the truck bed.

## TROUBLESHOOTING TIPS

**Leaning Rails:** If the rails are leaning down, have one person stand on the outside of the bed and slightly roll the rails upward while another person slowly snugs the clamps up. If the clamps are tightened too quickly or overtightened, it will cause the rails to lean down.

**Water Intrusion:** Make sure front retaining clamps are tight and properly engaged to the side rails. Check that the bulkhead seal is in place and the cover is resting on it. Make sure that all latches are engaged to the side rails and adjust if needed. Check that the side rails are installed flush with the top of the bed rail.

**Sticking Latch:** The cable could be pinched in or under the cable guide extrusion. Loosen the three screws on the center cable cover (bar), located in the middle of the panel. Slightly lift up on the cable guide extrusion. Pull on both sides of the cable.

**Wavy Side Seal:** The seal may be wavy when removed from the box. Allow 3-5 days in warm sunlight to lay down and relax.

# LIMITED WARRANTY

## WARRANTY COVERAGE

This truck bed cover is warranted against defects in materials or workmanship as follows. This warranty is void if the product has been damaged in an accident, or due to neglect, unforeseeable use, improper installation, improper servicing, or other cause not arising out of defects in material or workmanship.

The truck bed cover carries a limited warranty for **three (3) years** from the original date of purchase, subject to the terms below.

## WARRANTY IS NOT TRANSFERABLE

The warranty is to the initial owner purchasing the truck bed cover and it is not transferrable to a subsequent end user. Proof of purchase may be required to enforce these warranty rights.

## WARRANTY CONDITIONS

Failure to follow care and use instructions will void the warranty.

- Clean with mild automotive soap and water only.
- Cover must be secured at all points when vehicle is in motion.
- Check all clamps and retention mechanisms for tightness after a week of driving following installation (or re-installation) of the cover and periodically thereafter.
- Before opening, the cover must be free of all foreign materials including snow and ice.
- Do NOT tow your vehicle from the rear with the cover on your vehicle. If towing from the rear is required, the cover MUST be removed from the vehicle and properly stored.

## WARRANTY PERFORMANCE

If all warranty conditions are met, a defective truck bed cover or hardware component will either be repaired or replaced (at our option). We reserve the right, for any warranty, to substitute a newer model or bed cover having similar form and function, to offer a warranty discount on an entire replacement system, and/or provide remedies other than those mentioned in this document.

## WARRANTY RETURN

A Return Material Authorization number must be obtained from our Customer Service Department prior to returning any product. We may require the original item to be returned postage prepaid for final determination. Shipping charges will apply for any repair or replacement. Other than postage or shipping charges, no charge will be made for repair or replacement under this warranty.

This warranty gives you specific legal rights. As an owner, you may also have additional rights and remedies under the laws of your state.

## WARRANTY REGISTRATION

Warranty registration must be on file and/or proof of original purchase (detailed and dated receipt) required for warranty to be effective.

<https://realtruck.com/undercover-warranty>

**REGISTER  
YOUR  
WARRANTY  
ONLINE**



Serial Number \_\_\_\_\_

Date of Purchase \_\_\_\_\_