

INSTALLATION INSTRUCTIONS

CUSTOMER SERVICE

Phone: 877-878-9336 • 8:00 am - 5:00 pm Mon - Fri CT

Email: customersupport@truxedo.com



OWNER'S MANUAL TOYOTA TACOMA 24+

Damaged or missing parts? Call 877-878-9336 Mon - Fri 8 a.m. - 5 p.m. CT
Parts will be shipped to you factory direct. Do not return kit to place of purchase.

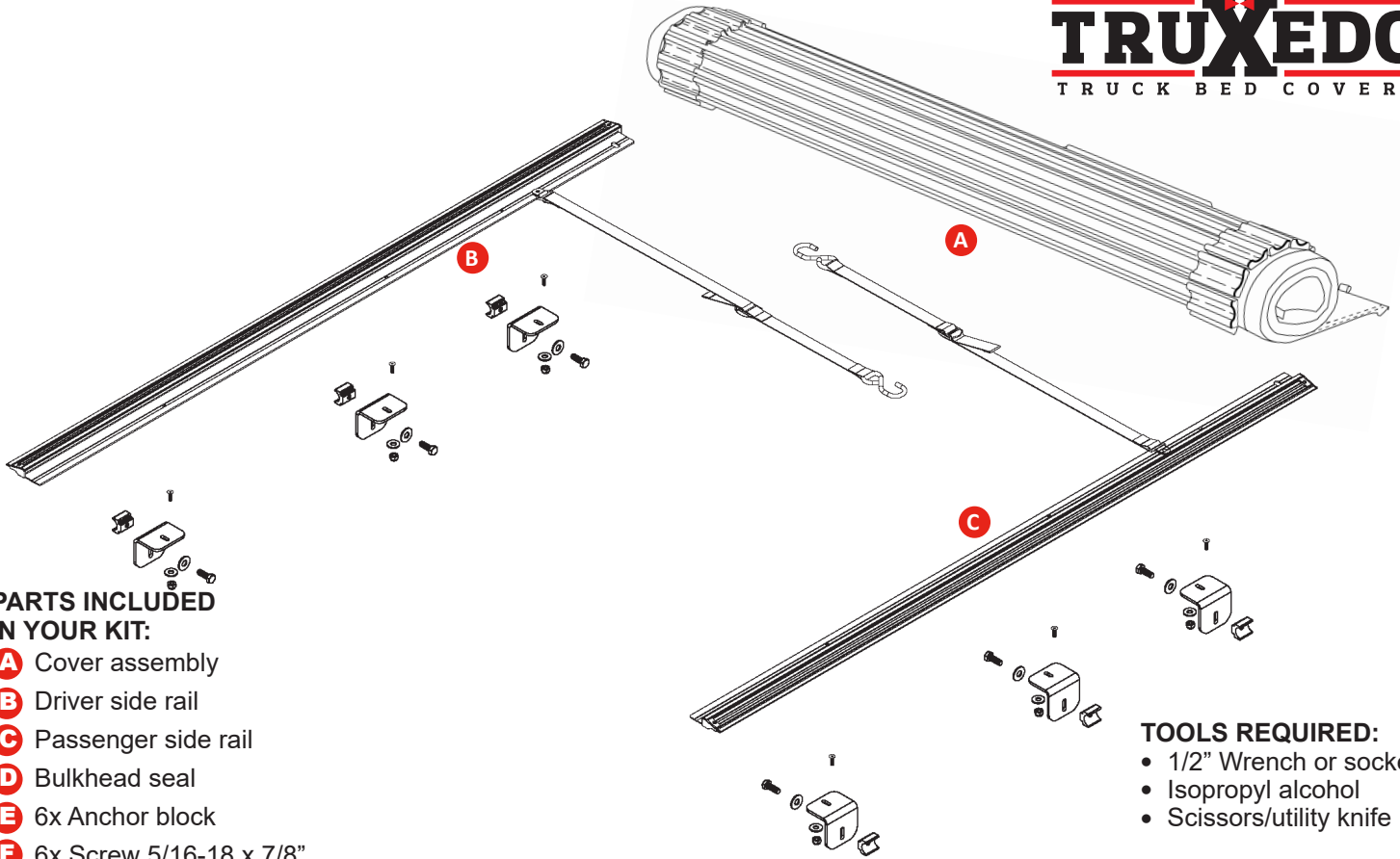

PARTS INCLUDED IN YOUR KIT:

- A** Cover assembly
- B** Driver side rail
- C** Passenger side rail
- D** Bulkhead seal
- E** 6x Anchor block
- F** 6x Screw 5/16-18 x 7/8"
- G** 6x Washer, 5/16"
- H** 6x Rail Attachment Bracket
- I** 6x Screw 1/4-20 x 3/4"
- J** 6x Flat Washer 1/4"
- K** 6x Nylock Nut, 1/4-20

- TOOLS REQUIRED:**
- 1/2" Wrench or socket
 - Isopropyl alcohol
 - Scissors/utility knife

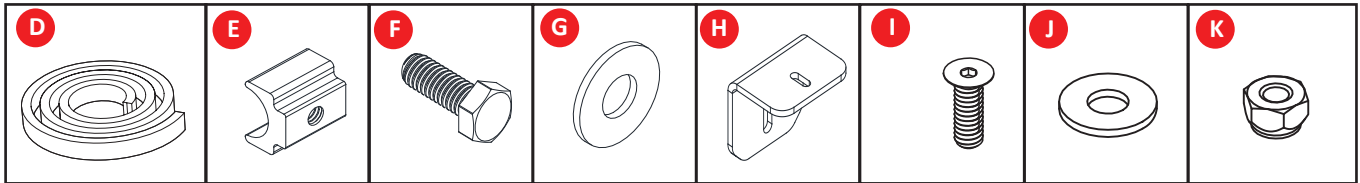

1 The serial number for the cover is located here.

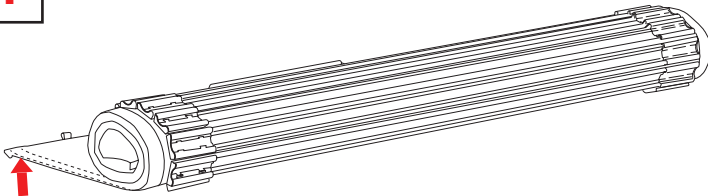

For future reference, write it here:

2 It is important that all areas where the bed cover mounts are clean and free of debris prior to installing.

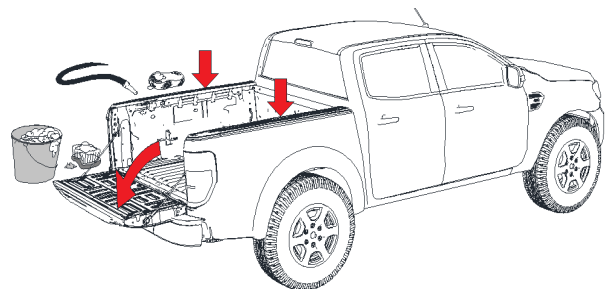

3 Install the bulkhead weather seal (D) to the truck's front bulkhead: Clean the area where the seal will go with soap and water to remove dirt and debris. Then clean the area with isopropyl alcohol to remove wax or grease and to evaporate any remaining water, allow the surface to dry. Then position the seal and apply pressure to the entire seal to make sure the adhesion is good.

Install corner support block seals (J): Peel off the protective layer to expose the adhesive surface of the weather seal. Apply the corner support block seals to the front corners of the truck bed. Position them carefully into the front corners of the truck bed, right under the bulkhead seal. Ensure that they are aligned properly and positioned where the bulkhead seal lacks support from the cargo rail. Do this at both front corners of the truck box.

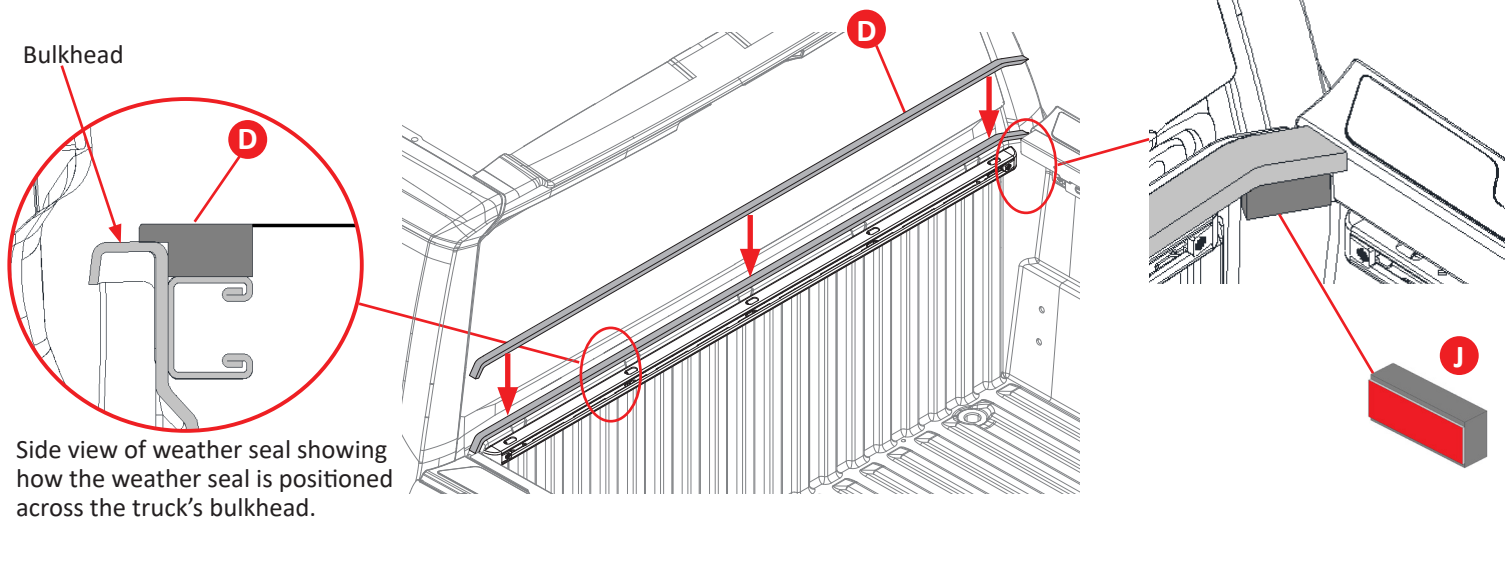

4 Remove cargo rail end plugs: Begin by pushing in on the end plug tab and at the same time push the end plug out of the rail.

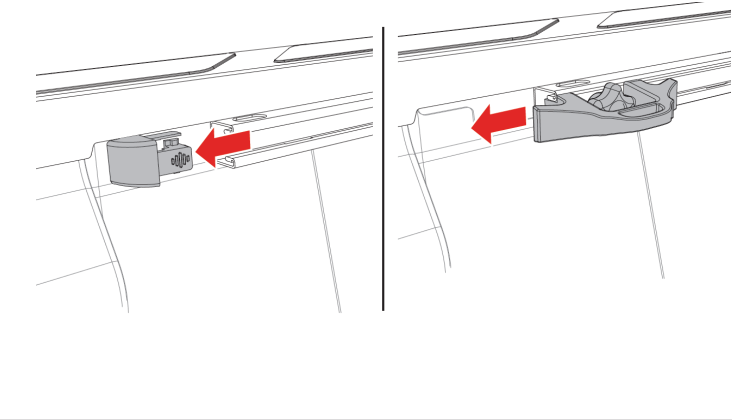

5 Install 3 anchor blocks (E) into the accessory rail from the tailgate end. Then put the end cap back into the tailgate end of the accessory rail. Repeat installation for drive side.

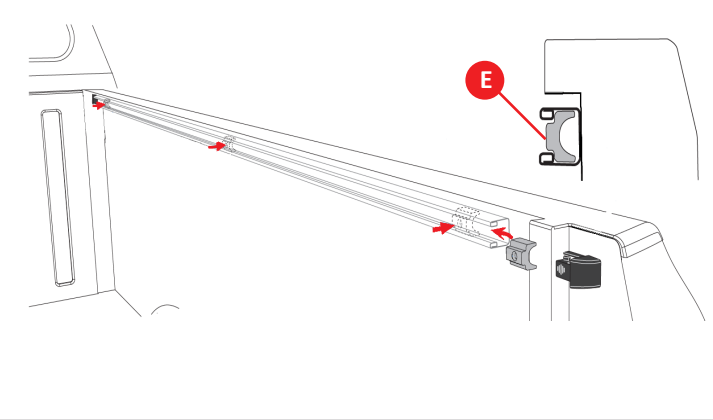

6 Fastening: Use 5/16 x 7/8" long screws (F) along with 5/16 washers (G) to attach the formed brackets to the anchor blocks. Insert the screws through the aligned holes on the brackets and anchors, placing washers between the screw heads and the brackets for secure attachment.

Positioning: Inside each cargo rail, position the brackets and anchors as follows: Ensure there is one bracket at the cab, one in the middle, and one at the tailgate of the cargo rail. Repeat the same process for both the driver side and the passenger side of the cargo rail.

Leave fasteners loose: It's important to leave all fasteners loose at this stage. This allows for adjustments to be made later on to ensure proper alignment and fitment of the side rails (A) and (B) to the brackets.

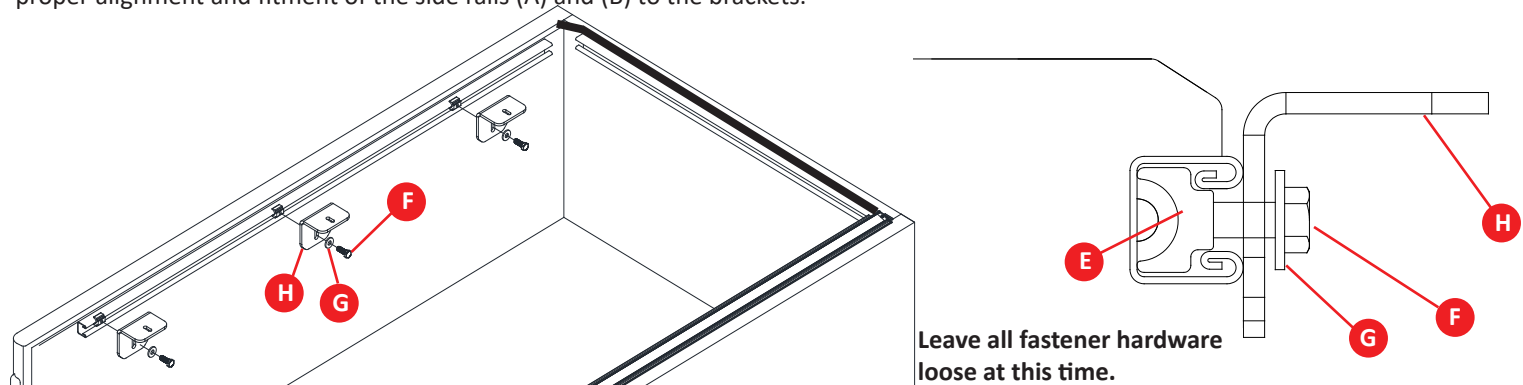

7 To attach the side rails to the formed brackets, follow these steps:

Positioning: Place the side rails (A) and (B) onto the formed brackets (H) that you have previously attached to the cargo rail anchors. Ensure that the side rails are positioned securely and aligned properly with the formed brackets.

Fastening: Use 1/4 x 3/4" screws (I) along with 1/4 washers (J) and 1/4" nylon locking nuts (K) to fasten the side rails to the formed brackets. Insert the screws through the holes in the side rails and brackets, placing washers between the screw heads and the side rails for added stability. Secure the screws with the nylon locking nuts.

Leave fasteners loose: At this stage, it's crucial to leave all fasteners loose. This allows for adjustments to be made later on to ensure proper alignment and fitment of the side rails. Tightening the fasteners prematurely may make adjustments difficult.

Leave all fastener hardware loose at this time.

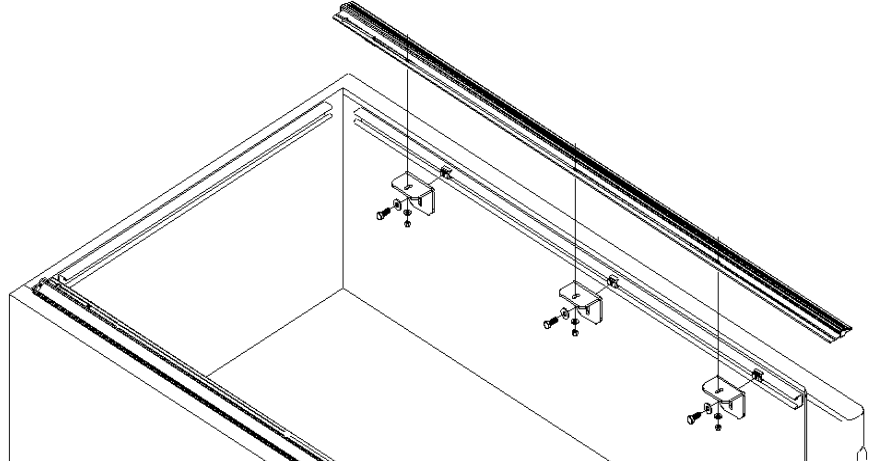
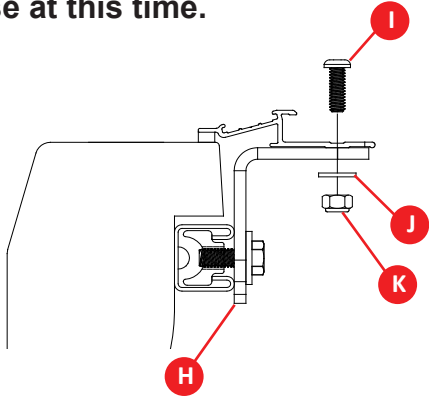

8 Position assembled side rails from the closed tailgate: With the truck's tailgate closed, position the end of each rail approximately 1/2" away from the rear corner of the truck bed. This positioning helps ensure proper alignment of the rail system and allows for clearance when opening and closing the tailgate.

Repeat for passenger rail: Repeat the entire process to install the passenger rail on the opposite side of the truck bed. Follow the same steps to position brackets, align anchor blocks, fasten rail brackets, and position the end of the rail.

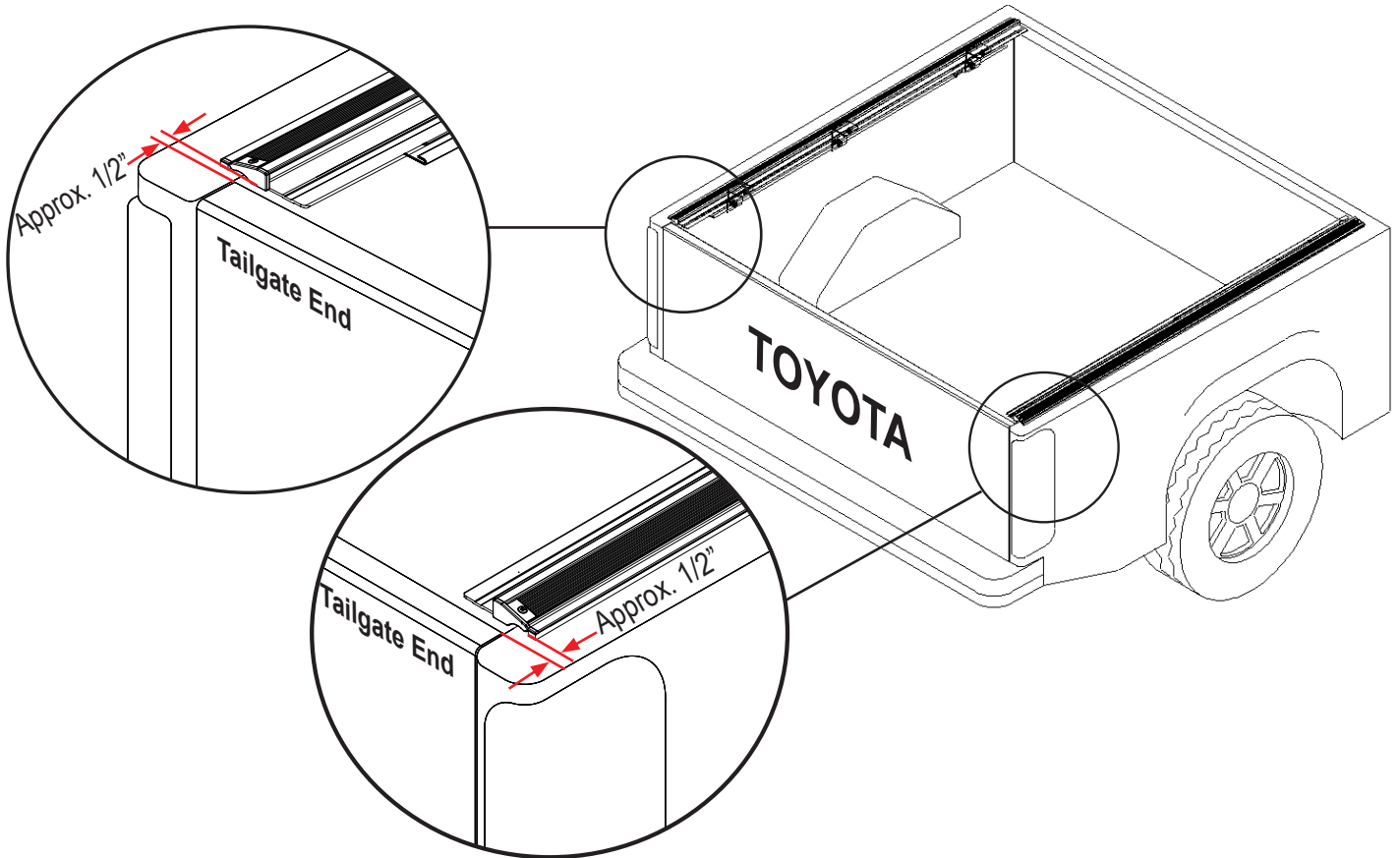

9 **Adjusting the cross car spacing of side rails (A) and (B) at the tailgate end of the truck bed:** At this point, the side rails should already be spaced correctly fore and aft (lengthwise), focusing now on the side-to-side spacing at the tailgate end.

Measuring the proper placement: Use a tape measure to help place the side rails 2" from the inside edge of the trucks plastic bed cap. The goal is to have equal spacing on both sides to ensure symmetry and proper alignment.

Secure the side rails (A) and (B): Once the rails are correctly aligned with equal spacing on both sides at the tailgate end, proceed to tighten any loose hardware on the rear brackets. Apply downward pressure on the rails while tightening the fasteners to ensure proper sealing.

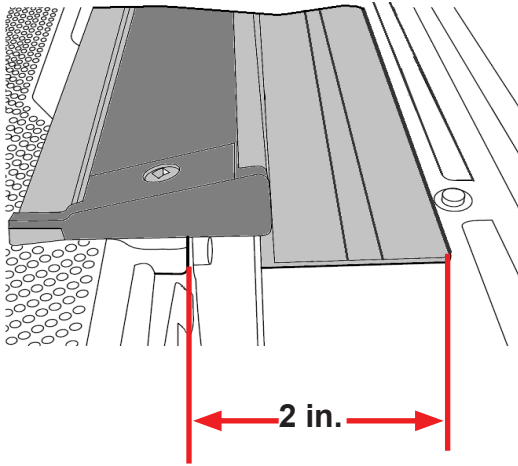

Space the Driver and Passenger side rails 2 inches from each bed cap at the tailgate end. While holding rail at 2 inches apply pressure downward on the rail and tighten both bolts in each rear bracket.

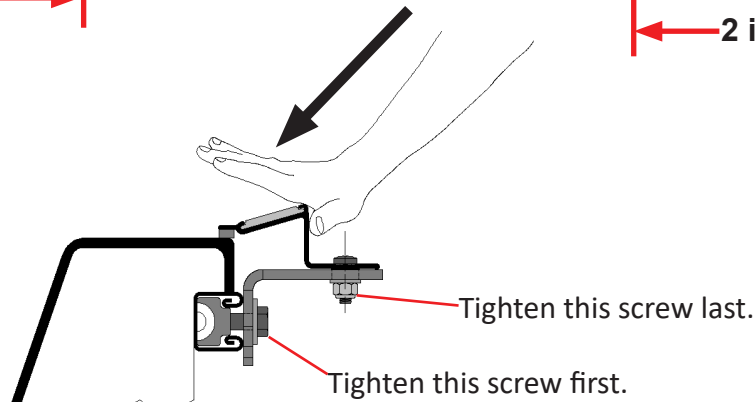
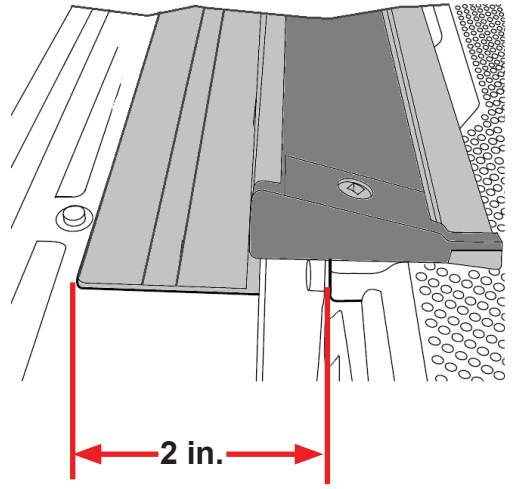

10 **Adjusting the cross car spacing of side rails (A) and (B) at the cab end of the truck bed:** At this point, the side rails should already be spaced correctly fore and aft (lengthwise), focusing now on the side-to-side spacing at the cab end.

Measuring the proper placement: Use a tape measure to help place the side rails 2-5/8" from the inside edge of the trucks plastic bed cap. The goal is to have equal spacing on both sides to ensure symmetry and proper alignment.

Secure the side rails (A) and (B): Once the rails are correctly aligned with equal spacing on both sides at the cab end, proceed to tighten any loose hardware on the front brackets. Apply downward pressure on the rails while tightening the fasteners to ensure proper sealing.

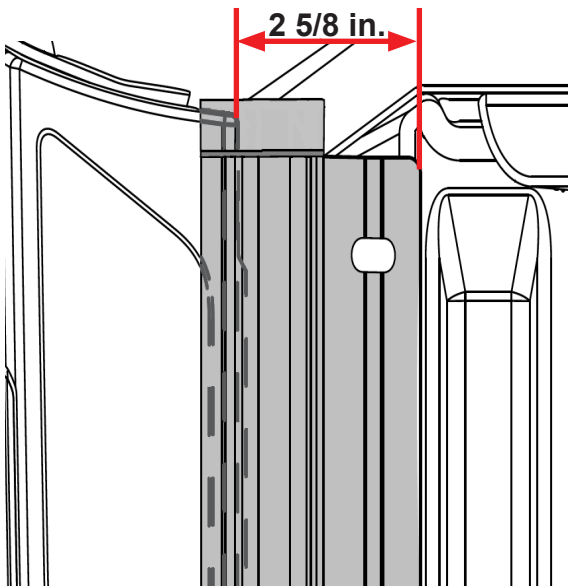

Space the driver and passenger side rails 2-5/8 inches from each bed cap at the cab end. While holding rail at 2-5/8 inches apply pressure downward on rail and tighten both bolts in each front bracket.

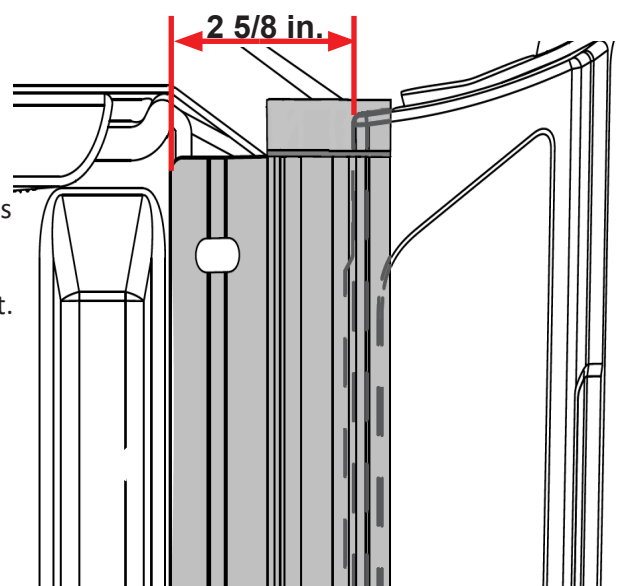

Measure 2 5/8 inches from bedcap to edge of rail as shown in these pictures.

- 11** To ensure cover assembly (A) is square for proper operation, make sure attachment holes on the driver and passenger side rails (B & C) are lined up across from each other.

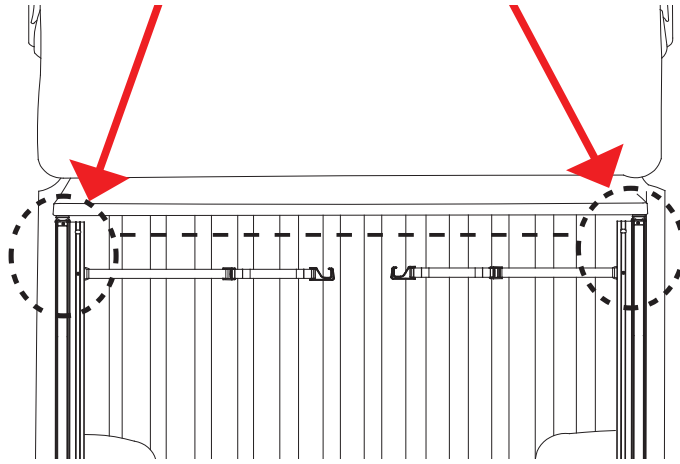

- 12** Place the cover assembly (A) on the side rails (B & C) towards the front of the truck bed (near the cab).

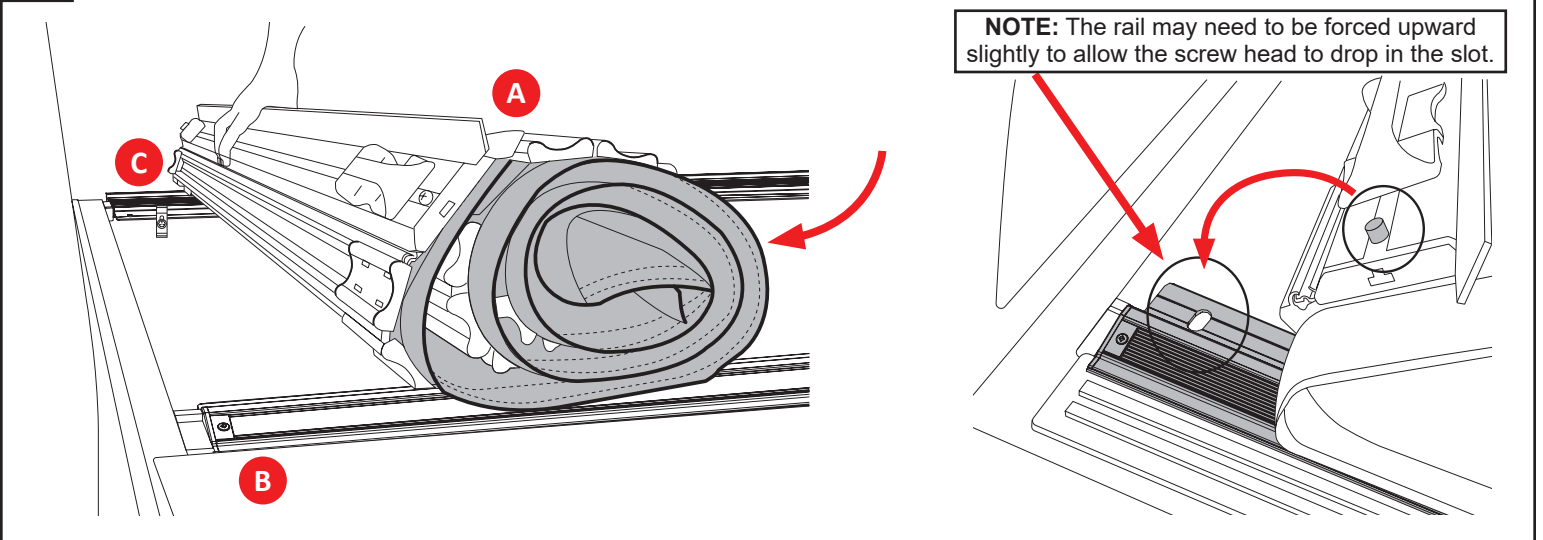

- 13** To connect the cover assembly (A) to the side rails (B & C), slide the right and left header guides into the locked position. A clicking sound will indicate a secure attachment.

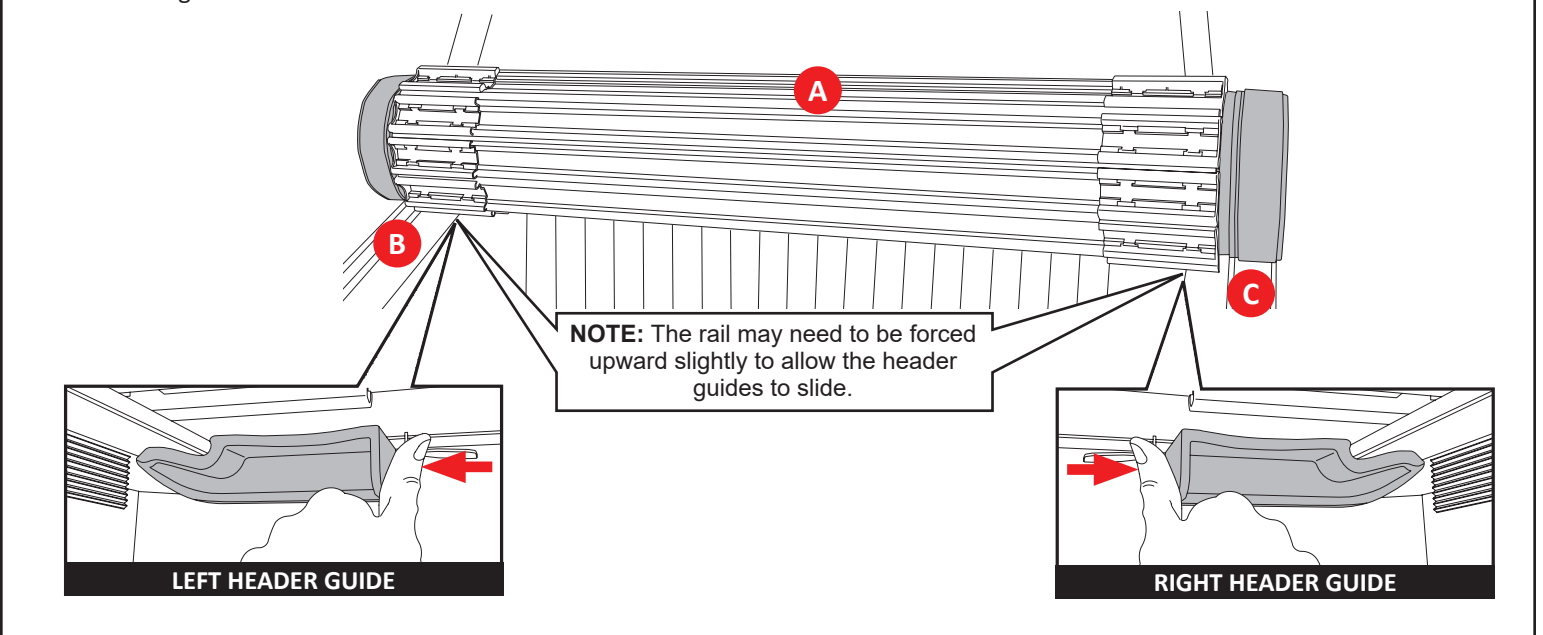

14 Unroll cover to tailgate.

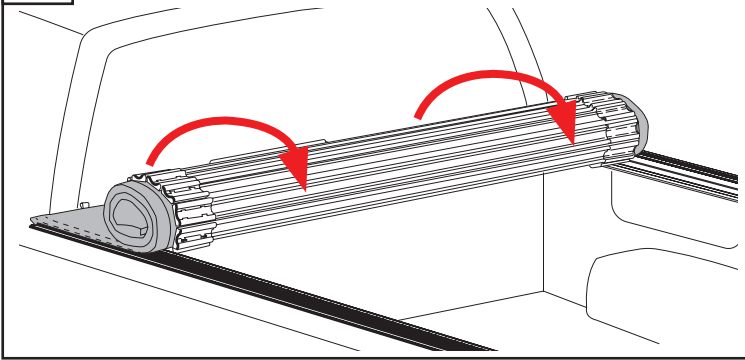

15 Push down on both ends of the cover (A), near the tailgate, to latch the driver and passenger slam latches. A clicking sound will indicate a correctly installed cover.

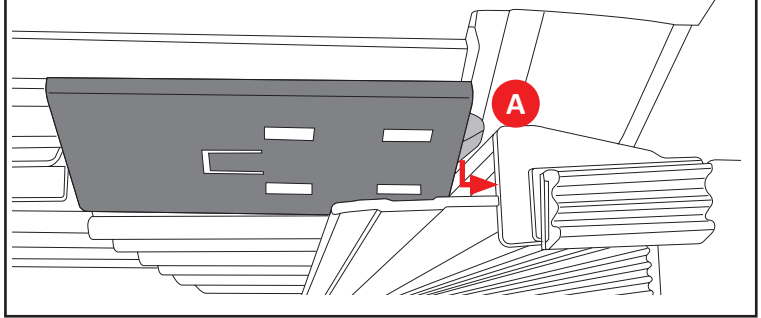

16 Preferred method of closure: Close tailgate, then close cover on top of tailgate. This method will not work with some truck applications. Use alternative method instead.

Alternative method of closing cover: Close and latch cover, then close tailgate with the seal inside the tailgate. It will take a little time to train the seal to close on the inside.

PREFERRED

ALTERNATIVE

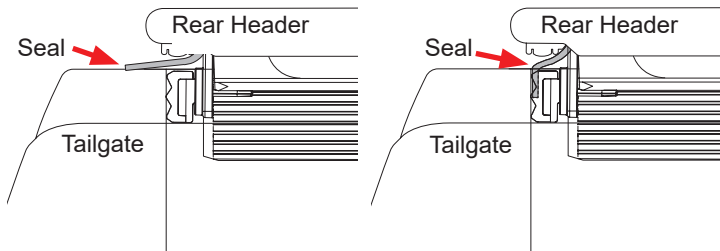

NOTE: If you have a key lock tailgate, the truck bed cover is secured until the tailgate is unlocked and opened.

NOTE: Make sure cover is securely latched on both sides before operating vehicle.

17 Secure the hook and loop down both sides along the entire length of the truck bed cover before driving the vehicle. This will prevent wind from lifting the cover and causing damage.

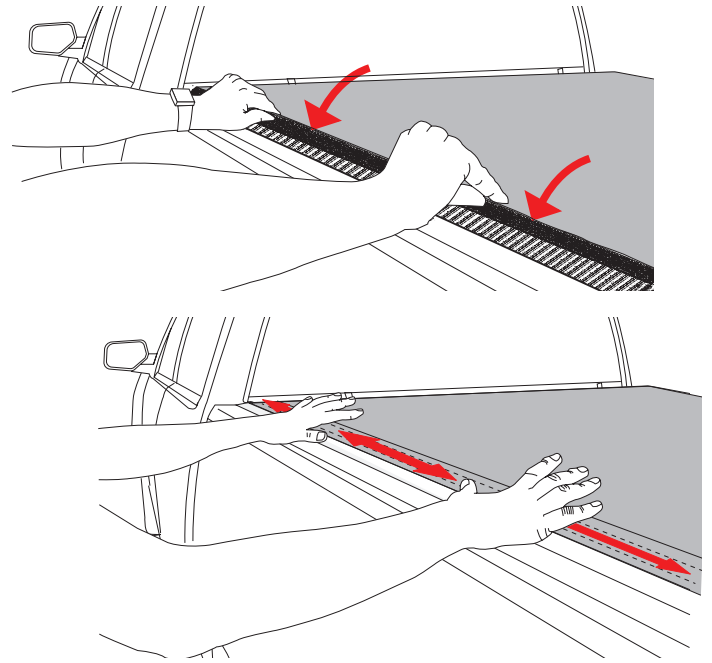

ATTENTION:

After the initial installation leave cover closed and latched for 24 hour period. This will ensure that the fabric has completely set to the metal substrate.

OPENING THE COVER

To open cover, pull down on release cable and hold down. Lift and roll tail header toward the cab.

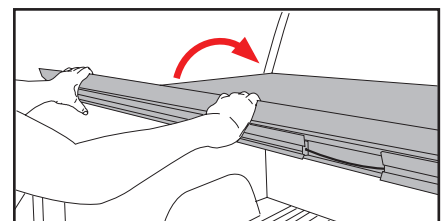
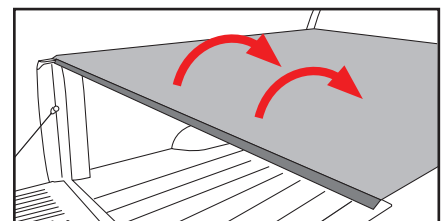
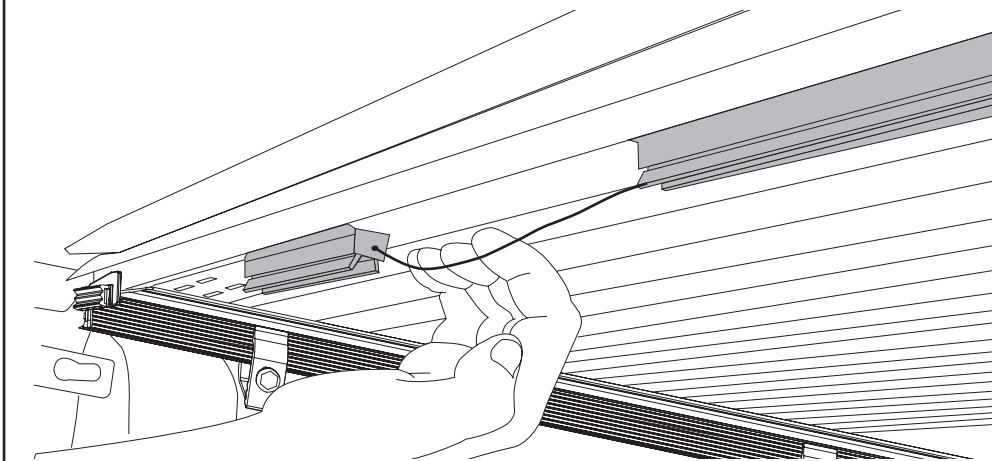

SECURING THE COVER

Roll cover tight. Secure the cover appropriately using both retainer straps. Do not over tighten. Do not stow cover against cab window.

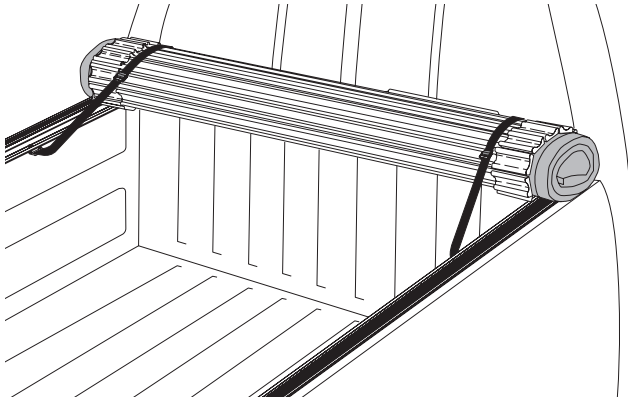

Before driving with the cover open, both straps must be secured to retaining loops. Failure to do so could cause accidental release of the cover, resulting in personal injury or property damage.

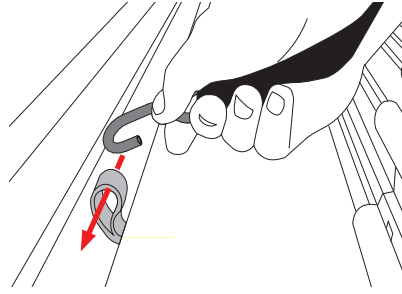

To release strap push tab up. **NOTE:** Ice buildup within hinge sections can occur if cover is stowed in open position. To prevent potential damage, close cover during winter precipitation.

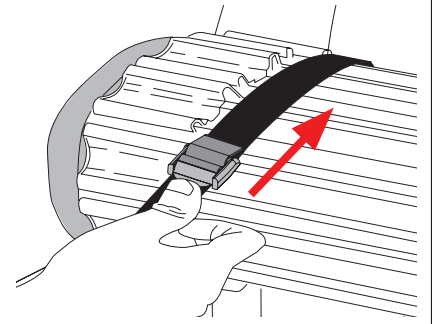

LIMITED WARRANTY

WARRANTY COVERAGE

This truck bed cover is warranted against defects in materials or workmanship as follows. This warranty is void if the product has been damaged in an accident, or due to neglect, unforeseeable use, improper installation, improper servicing, or other cause not arising out of defects in material or workmanship.

SENTRY: LIMITED THREE-YEAR WARRANTY ON HARD PARTS

All hardware included with your truck bed cover, including rails, clamps and bows carry a limited warranty for three (3) years from the original date of purchase, subject to the terms below.

SENTRY: LIMITED THREE-YEAR WARRANTY FOR FABRIC

The fabric on your truck bed cover carries a limited warranty for three (3) years from the original date of purchase, subject to the terms below.

SENTRY CT: LIMITED FIVE-YEAR WARRANTY ON HARD PARTS

All hardware included with your truck bed cover, including rails, clamps and bows carry a limited warranty for five (5) years from the original date of purchase, subject to the terms below.

SENTRY CT: LIMITED FIVE-YEAR WARRANTY FOR FABRIC

The fabric on your truck bed cover carries a limited warranty for five (5) years from the original date of purchase, subject to the terms below.

WARRANTY IS NOT TRANSFERABLE

The warranty is to the initial owner purchasing the truck bed cover and it is not transferrable to a subsequent end user. Proof of purchase may be required to enforce these warranty rights.

WARRANTY CONDITIONS

Failure to follow these warnings and care instructions will void the warranty:

- Clean with mild automotive soap and water only.
- Do not use conditioners that contain silicone or petroleum.
- The tonneau cover must be secured at all points when the vehicle is in motion. When not fully closed with the rear latch engaged the cover must be completely rolled up and secured at the cab with both provided retainer straps attached. Do NOT drive with the bed cover in a partially open position.
- Do NOT tie cargo to truck bed cover framework.
- Check rail clamps for tightness after a week of driving following the installation of the cover and periodically thereafter.
- Do NOT roll the cover into the rear cab window. Do NOT stow the cover against the cab of the truck.
- If the cover is going to be rolled open for an extended amount of time, periodically re-roll the cover and secure the retainer straps to ensure the cover doesn't rest against the cab of the truck.
- Before opening, the cover must be free of all foreign materials including snow and ice.
- Do NOT tow your vehicle from the rear with the cover on your vehicle. If towing from the rear is required, the cover MUST be removed from the vehicle and properly stored.

WARRANTY PERFORMANCE

If all warranty conditions are met, a defective truck bed cover, tarp, or hardware component will either be repaired or replaced (at our option). We reserve the right, for any warranty, to substitute a newer model of bed cover having similar form and function, to offer a warranty discount on an entire replacement system, and/or provide remedies other than those mentioned in this document.

WARRANTY PROCESS

A Return Material Authorization number must be obtained from our Customer Service Department prior to returning any product. We may require the original item to be returned postage prepaid for final determination. Shipping charges will apply for any repair or replacement. Other than postage or shipping charges, no charge will be made for repair or replacement under this warranty.

This warranty gives you specific legal rights. As an owner, you may also have additional rights and remedies under the laws of your state.

WARRANTY REGISTRATION

Warranty registration must be on file and/or proof of original purchase (detailed and dated receipt) required for warranty to be effective.

Please register online at <https://realtruck.com/truxedo-warranty>

REGISTER
YOUR
WARRANTY
ONLINE



SAFETY INSTRUCTIONS

- DO NOT place objects on or against cover or framework.
- DO NOT tie cargo to truck bed cover framework.
- Never allow children or pets to occupy pickup box while cover is closed.
- Cover is not airtight. Special care is required to keep cargo clean and dry.
- Tonneau covers won't prevent theft of contents inside truck box.
- DO NOT stow rolled cover against cab window.
- DO NOT attempt to drive with the cover in the partially open position!
- A fully rolled open cover must always be secured with retainer straps.
- DO NOT operate vehicle with objects on top of the cover.
- CAUTION - Pinch points can cause serious personal injury.
- CAUTION - Metal parts can get extremely hot if left in bright sun and or heat.

TROUBLESHOOTING TIPS

COVER ASSEMBLY WILL NOT ATTACH TO SIDE RAILS DURING INSTALLATION

- Check side rails to make sure they are level.
- The rolled-up cover is heavy which may be flexing the rails downward. Push front of rail up slightly to allow the screw head to fall in the slot and the header guide to slide freely into the secured location.
- If rear header doesn't latch correctly check side rail installation.

HEADER WILL NOT LATCH

- Check side rails to make sure they are level.
- Make sure the rear header seal is not caught between side rail & rear header.
- If rear header doesn't latch correctly check side rail installation.
- Check to make sure side rails are both equally spaced front to rear.
- Make sure both latches are functioning properly. Clean any debris that may be impeding latches.

COVER CARE AND MAINTENANCE

- Clean with soap and water. The cover can be treated with any vinyl protectant specifically made for tonneau covers.
- It is recommended that you periodically check that the cover is securely attached to your truck bed. Inspect the clamps and front header guide slides to ensure they were properly installed and have not come loose during operation.
- It is recommended that you periodically inspect and service the rear latch closure. Clean away any excess dirt or grime.
- Covers that are used frequently or are subject to vibrations and impacts from rough roadways may require adjustment.

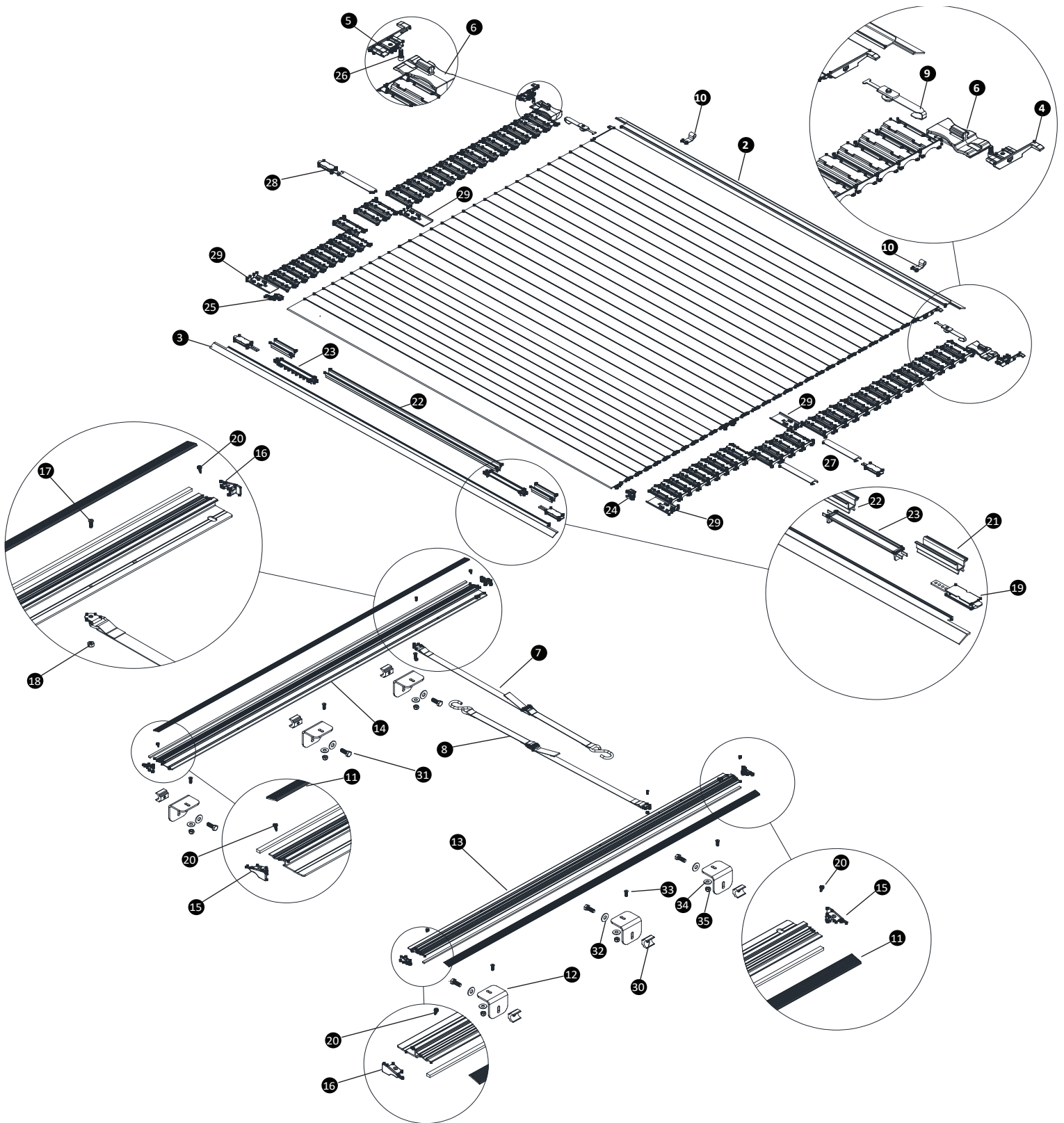

Replacement Parts

1	*	Sentry/Sentry CT Replacement Cover	14	*	Side Rail, Driver's Side	26	1704689	Machine Screw 1/4-20 X 9/16
2	*	Header Seal Front	15	1706245	Side Rail End Plug Assy_RH	27	*	Passenger Security Latch Assy
3	*	Header Seal Rear	16	1706246	Side Rail End Plug Assy_LH	28	*	Driver Security Latch Assy
4	1705828	Front Header End Plug (Passenger)	17	1705415	Cap Screw 10-24 X 1/2	29	1705929	Latch Cover
5	1705829	Front Header End Plug (Driver)	18	1703762	Hex Nut 10-24	30	1703889	Anchor Block
6	1704707	Header Guide	19	*	Latch System	31	1702926	Screw 5/16-18 X 7/8
7	1117892	Retainer Hook Strap (Passenger)	20	1705629	Self Drill Screw 6-20 X 3/8	32	1700428	Washer 5/16
8	1117893	Retainer Hook Strap (Driver)	21	1118225	Cable Cover 3.75"	33	1706911	Screw 1/4-20 X 3/4
9	1117594	Header Guide Retainer	22	*	Cable Cover	34	1700427	Washer 1/4
10	1705806	Extruded Retainer Loop	23	1115822	Cable Guard	35	1701543	Nylock Nut 1/4-20
11	*	Hook and Loop Fasteners	24	1705826	Rear Header End Plug (Passenger)			
12	1705577	Rail Attachment Bracket	25	1705825	Rear Header End Plug (Driver)			
13	*	Side Rail, Passenger's Side						

* Please specify length or make and model of vehicle.