

## ⚠️ IMPORTANT

### READ BEFORE YOU BEGIN INSTALLATION

**IT IS CRITICAL FOR YOUR SAFETY THAT YOU CAREFULLY READ AND FOLLOW THE SAFETY CAUTIONS AND INSTALLATION INSTRUCTIONS BOTH PRIOR TO AND DURING INSTALLATION.**

#### USER SAFETY CAUTION

During installation, be mindful of the potential for sharp edges on the product or vehicle. Taking proper safety precautions helps ensure a safe and smooth installation process.

**Always wear protective gloves and handle components with care to reduce the risk of injury.**



#### TEMPERATURE SURFACE CAUTION

During high temperatures or extended sun exposure, surfaces of this product may become hot to the touch, posing a risk of burns or injury. Use caution when handling the product in hot weather and allow time for it to cool before contact.

**Always check surface temperature before use to ensure safe handling conditions.**



#### FASTENER TORQUE CAUTION

All fasteners must be tightened to the specified torque values provided in the installation instructions to ensure proper fit and safe operation of the tonneau cover. Under- or over-tightening can lead to product failure, potential damage to your vehicle, injury, or safety hazards while driving.

**Always use a calibrated torque wrench and follow the specifications in the installation instructions.**

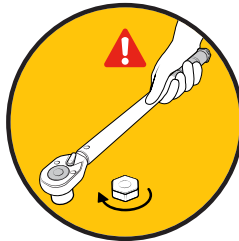

#### PINCH POINT SAFETY CAUTION

This tonneau cover may create pinch points when closing or operating near solid surfaces such as the truck bed rails or tailgate. To prevent injury, keep hands, fingers, and other body parts clear of moving parts during operation.

**Always operate the cover slowly and with caution to ensure safe and proper use.**



## ! IMPORTANT

### READ BEFORE YOU BEGIN INSTALLATION

**IT IS CRITICAL FOR YOUR SAFETY THAT YOU CAREFULLY READ AND FOLLOW THE SAFETY CAUTIONS AND INSTALLATION INSTRUCTIONS BOTH PRIOR TO AND DURING INSTALLATION.**

#### ENTRAPMENT SAFETY WARNING

This tonneau cover does not feature a manual release mechanism from inside the truck bed. To prevent the risk of entrapment, never allow anyone to be inside the bed of the truck when the cover is closed.

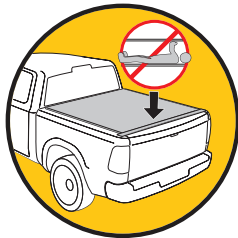

**Always ensure the area is clear before closing the cover, and keep the cover securely latched when not in use to avoid accidental closure.**

#### COVER ATTACHMENT WARNING

A partially rolled up or unsecured cover may detach during transit, risking vehicle or property damage and personal injury.

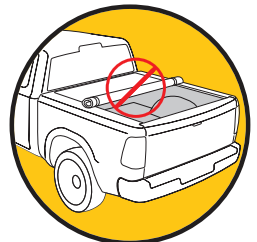

**Always verify the tonneau cover is properly secured before operating the vehicle.**

#### CARGO TRANSPORT WARNING

When transporting cargo that is taller than the truck bed, the cover must be fully rolled open and securely fastened with both retainer straps. An unsecured cover can detach while driving, risking vehicle or property damage and personal injury.



**Never operate the vehicle with a partially rolled up cover.**

#### COVER POSITION WARNING

Before operating the vehicle, always verify the tonneau cover is either fully rolled open and secured with both retainer straps or fully rolled closed and securely latched down.

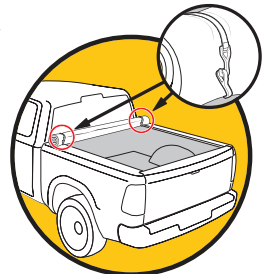

**Never operate the vehicle if the tonneau cover is not properly secured.**

**Any damaged or missing parts?**

Parts will be shipped to you directly.

Call 877-878-9336, Mon - Fri, 8:00 a.m. - 5:00 p.m. CT

**NOTE:** It is important that all areas where the bed cover mounts are clean and free of debris prior to installing.

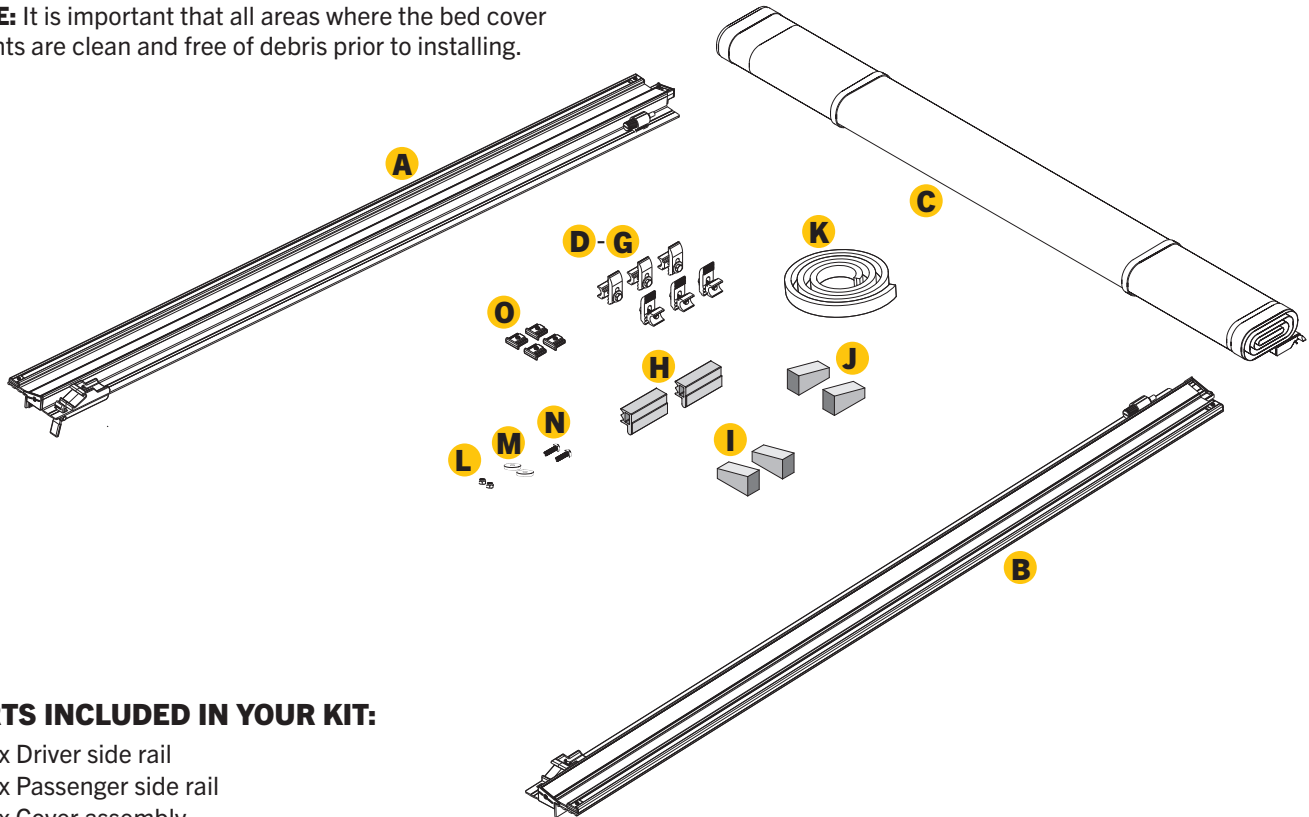

### PARTS INCLUDED IN YOUR KIT:

- A** 1x Driver side rail
- B** 1x Passenger side rail
- C** 1x Cover assembly
- D-G** 6x Male clamp ends
- E** 6x Female clamp ends
- F** 6x Flat washers
- G** 6x Cap screws
- H** 2x Front corner seals
- I** 2x End plug seals
- J** 2x End plug seals
- K** 1x Bulkhead seal  
*(on select make/models)*
- L** 2x Hex nuts
- M** 2x Plastic washers
- N** 2x Square head bolts
- O** 4x T-slot end plugs

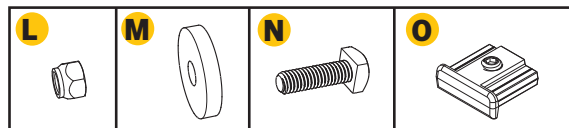
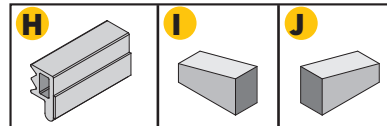
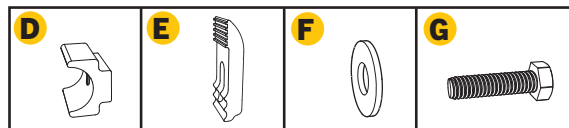

### TOOLS PROVIDED

- 1/8" Allen wrench

### TOOLS REQUIRED

- Flat head screwdriver
- 1/2" Wrench or socket
- Isopropyl alcohol

### TOOLS RECOMMENDED

- Spring clamps
- Scissors/utility knife

**1** The serial number for the cover is located here.

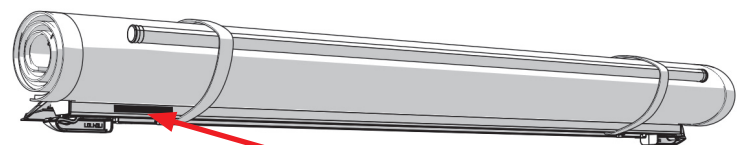

For future reference, write it here:

\_\_\_\_\_

**2** Install front seal (H) included with cover (A) by cleaning the front of the bulkhead with soap and water to remove dirt and debris. Clean the area with isopropyl alcohol to remove wax or grease and to evaporate any remaining water. Allow the surface to dry. Peel the white paper backing and adhere the seal in the valley between the bulkhead and the plastic truck bed caps as shown. Apply pressure evenly to the entire seal to ensure proper adhesion. Do this for both driver and passenger sides.

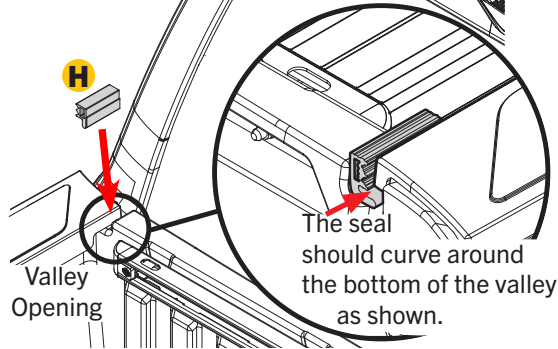

**3** Remove the rear cargo rail end plugs and remove the cargo tie-downs if installed.

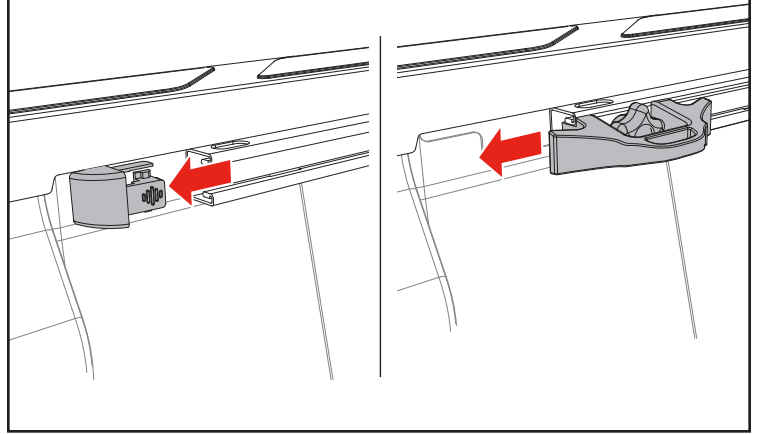

**4** Assemble the clamps by placing a cap screw (G) and a flat washer (F) through the female clamp end (E) then through the male clamp end (D), as shown below. There are 6 clamps in total, 3 per side rail.

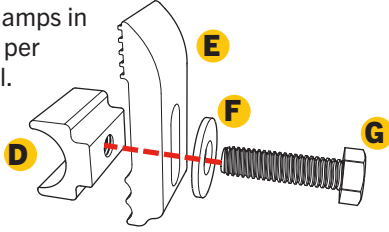

**5** Slide the assembled clamps (D-G) into the cargo rail. Space them evenly, leaving approximately 8" on each end of the cargo rail. Reinstall the tie-down cleats and the cargo rail end plugs.

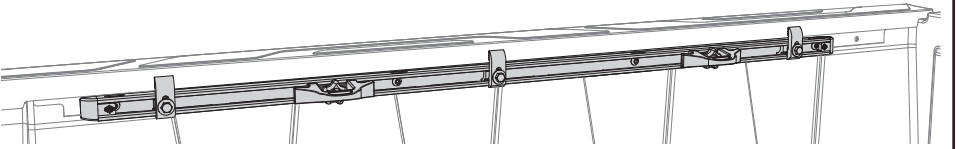
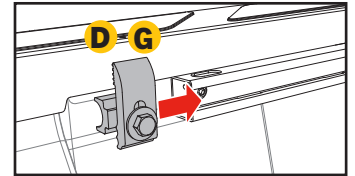

**6** Install end plug seals (I & J) included with cover (A) by cleaning the front of the side rails (A & B) with soap and water to remove dirt and debris. Clean the area with isopropyl alcohol to remove wax or grease and to evaporate any remaining water. Allow the surface to dry. Peel the white paper backing and adhere the seals to the front of the side rails (A & B) as shown. Apply pressure evenly to the entire seal to ensure proper adhesion. Install one T-slot end plug (O) in the front end of each side rail at this time and tighten down the set screw with a 1/8" Allen wrench.

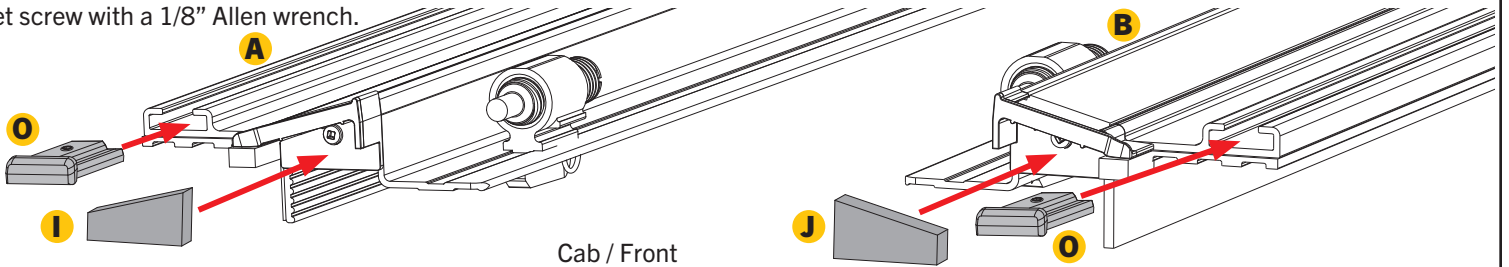

**7** Position the driver side rail (A) to the inside of the truck's bed rail, making sure the flange of the driver side rail fits on top of the bed cap. The front edge of the rails will be 3/8" back from the bulkhead.

The side rail flange must be positioned on top of the truck's bed cap as shown.

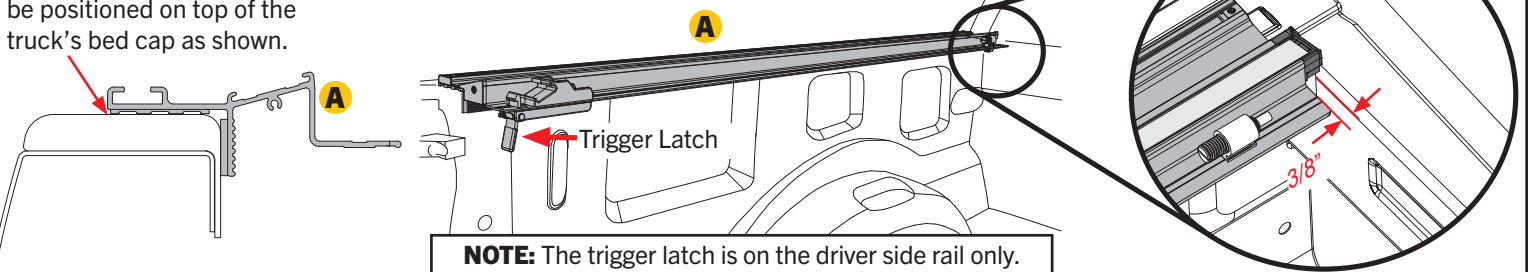

- 8** To secure the side rails (A and B) in place hand tighten the clamps (D-G) installed on the cargo rail.

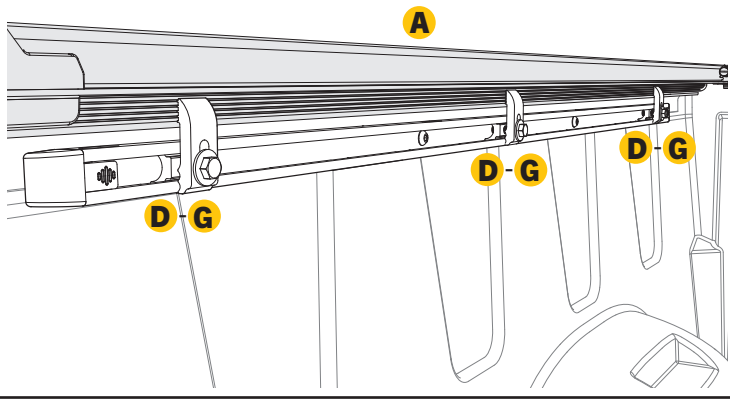

- 9** For optimal latching performance and cover fit, the side rails (A and B) should be level with the truck bed caps and not tilted up or down. Tighten all clamps with a 1/2" wrench or socket.

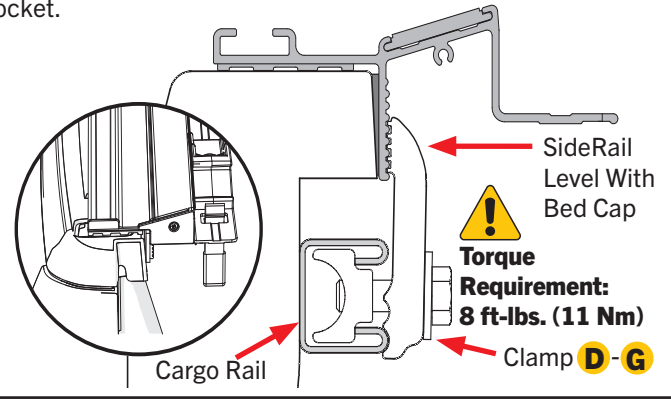

- 10** Install bulkhead seal (K) included with cover (A) by cleaning the top of the bulkhead with soap and water to remove dirt and debris. Clean the area with isopropyl alcohol to remove wax or grease and to evaporate any remaining water. Allow the surface to dry. Peel the white paper backing and adhere the seal from one bulkhead edge to the other. Remove any excess with scissors or a utility knife. Apply pressure evenly to the entire seal to ensure proper adhesion.

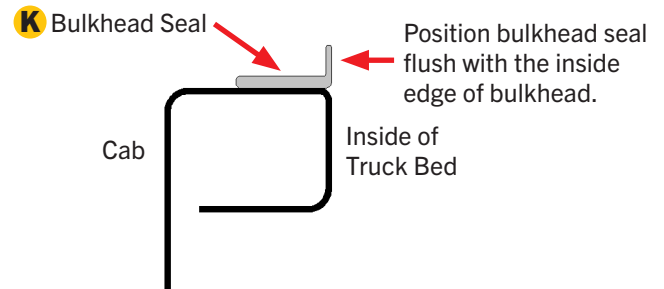
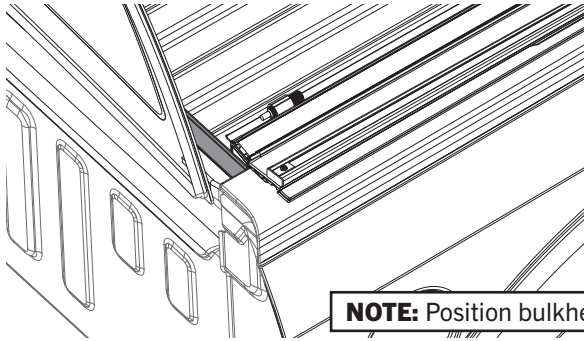

**NOTE:** Position bulkhead seal tight against rail endplug seal and bedcap.

- 11** Many truck tailgates, when closed, have corner gaps that allow moisture to enter the truck bed. Install end plug seals (I & J) included with cover (A) by cleaning the rear of the side rails (A & B) with soap and water to remove dirt and debris. Clean the area with isopropyl alcohol to remove wax or grease and to evaporate any remaining water. Allow the surface to dry. Peel the white paper backing and adhere the seals to the rear of the side rails (A & B) as shown. Apply pressure evenly to the entire seal to ensure proper adhesion. This blocks moisture from entering the truck bed at the tailgate.

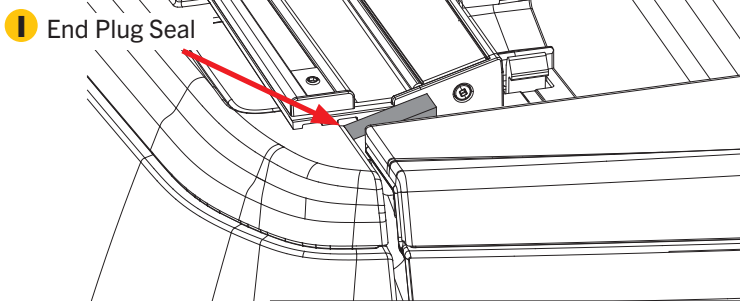

Driver Side Shown

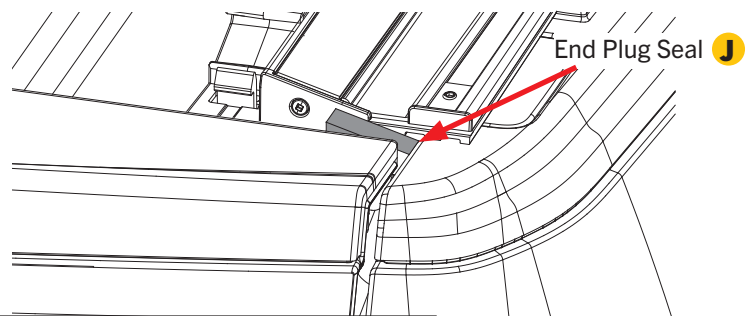

Passenger Side Shown

**NOTE:** If moisture does enter at the tailgate area then generally the moisture will run down the tailgate and out through the bottom of the tailgate and away from the truck.

- 12** On the cover assembly (C), identify the driver and passenger front header end plugs. Remove both plugs by pulling them outward as shown below.

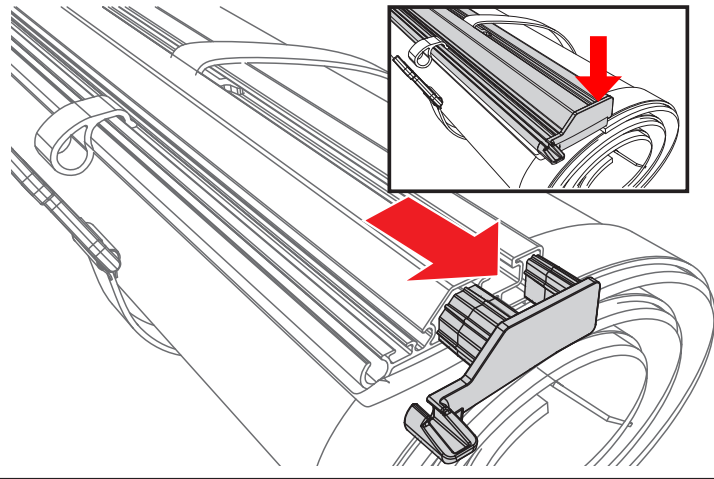

- 13** Install the square head bolts (N) by sliding them into the header as shown below. Do this on both driver and passenger sides. Then reinstall both end plugs.

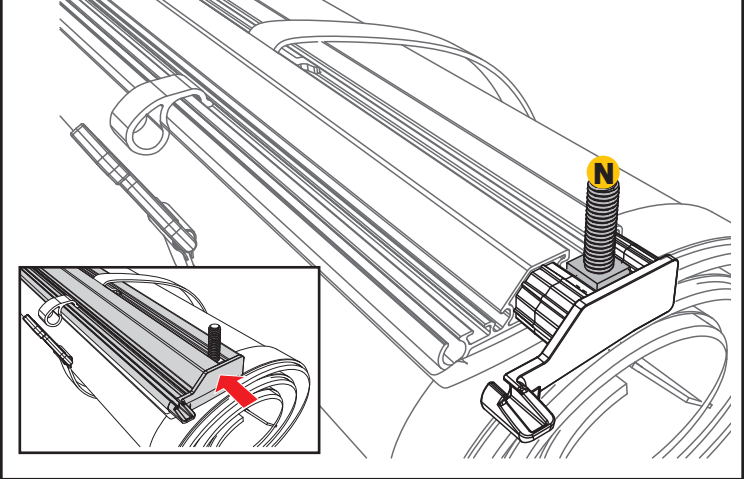

- 14** Place the cover (C) on the side rails towards the front of the truck bed (near the cab). The front header seal is designed to help shed water and should sit on top of the bulkhead.

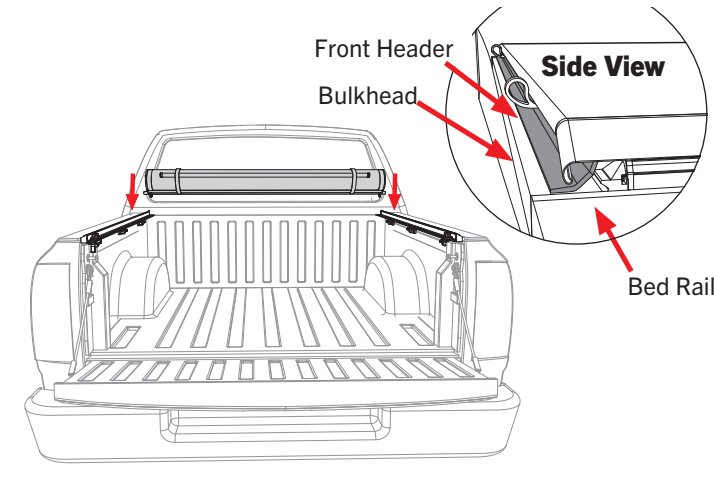

- 15** To connect the cover assembly (C) to the side rails (A and B), place the bolt (N) through the oblong hole in the side rails. Secure the cover assembly by installing a washer (M) and a hex nut (L) underneath the side rails at the cab with a 1/2" socket. Tighten the nut until resistance is felt, then back off the nut by a 1/4-1/2 turn.

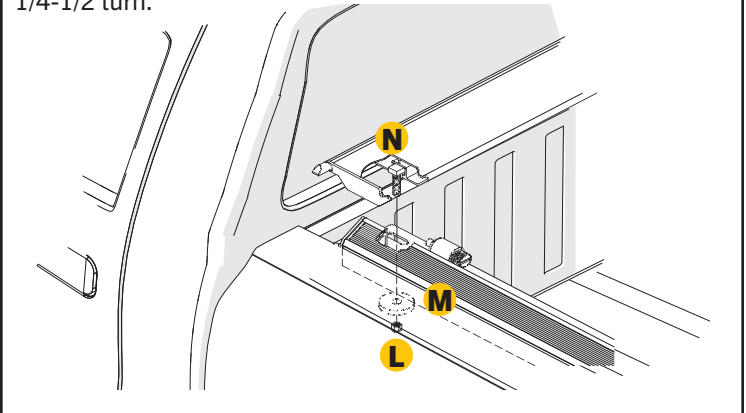

- 16** Disengage the retainer hooks from the retainer loops and unroll the cover towards the tailgate.

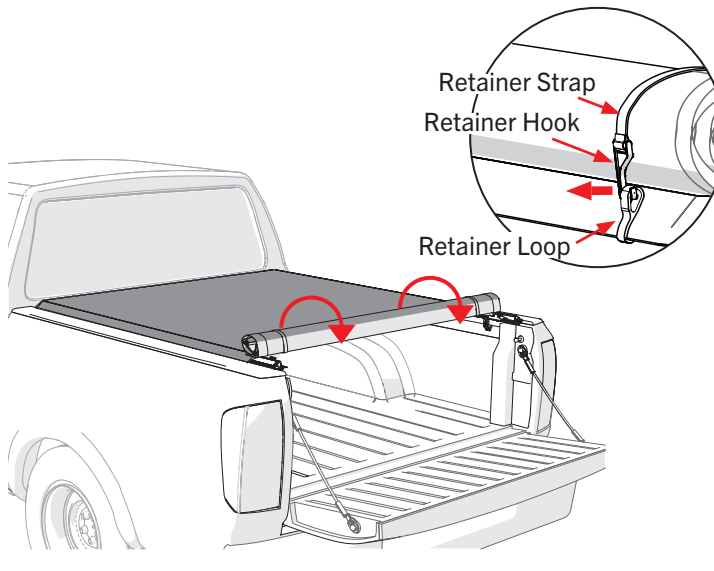

- 17** Place the rear header into the header stops which are located on both side rails. Rotate the rear header downwards until you feel the cover latch in place. A clicking sound will indicate a correctly installed cover.

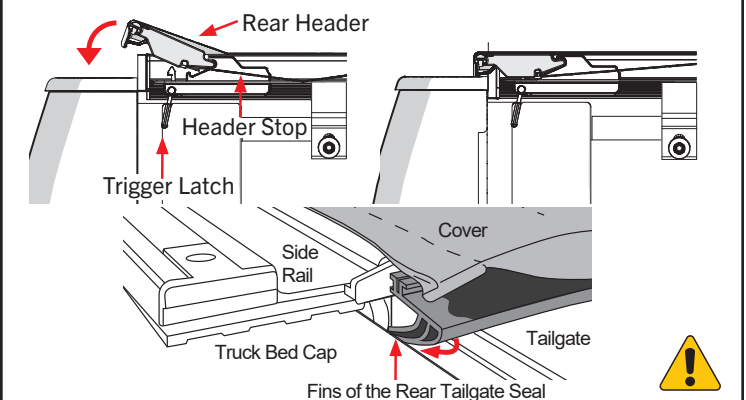

**NOTE:** When you close the tailgate, it pushes the fins toward the inside of the bed with the rest of the seal partially on top of the tailgate.

- 18** Once the cover is closed, grab the fabric flap and evenly pull it over the hook track engaging the loop to the hook.

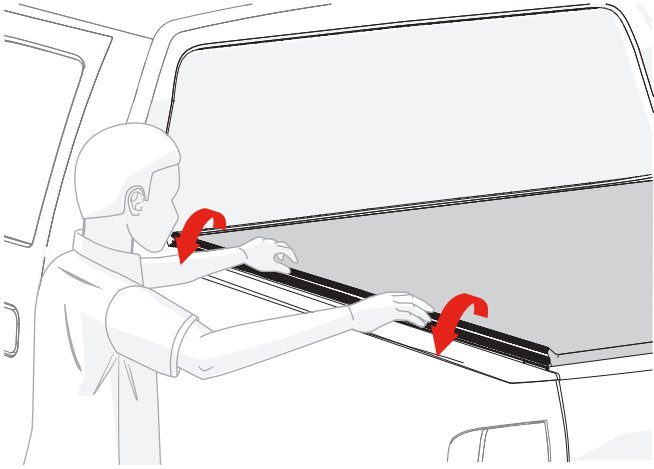

- 19** With both sides of the hook and loop engaged, use the palms of your hand to firmly push the loop strip into the hook track. Do this to both driver and passenger sides. You are ready to drive with the cover in the closed position.

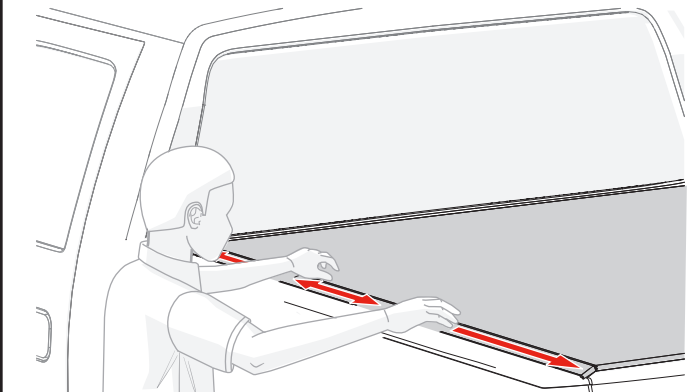

**!** **HOOK AND LOOP MUST ALWAYS BE ADJUSTED AFTER ROLLING COVER CLOSED!**

- 20** Once you are ready to install your accessory into the T-slot rails by sliding it through the rear slots in rails (A & B), re-install one T-slot end plug (O) in the rear/tail end of each side rail at this time. Then tighten down the set screw in each T-slot end plug with a 1/8" Allen wrench.

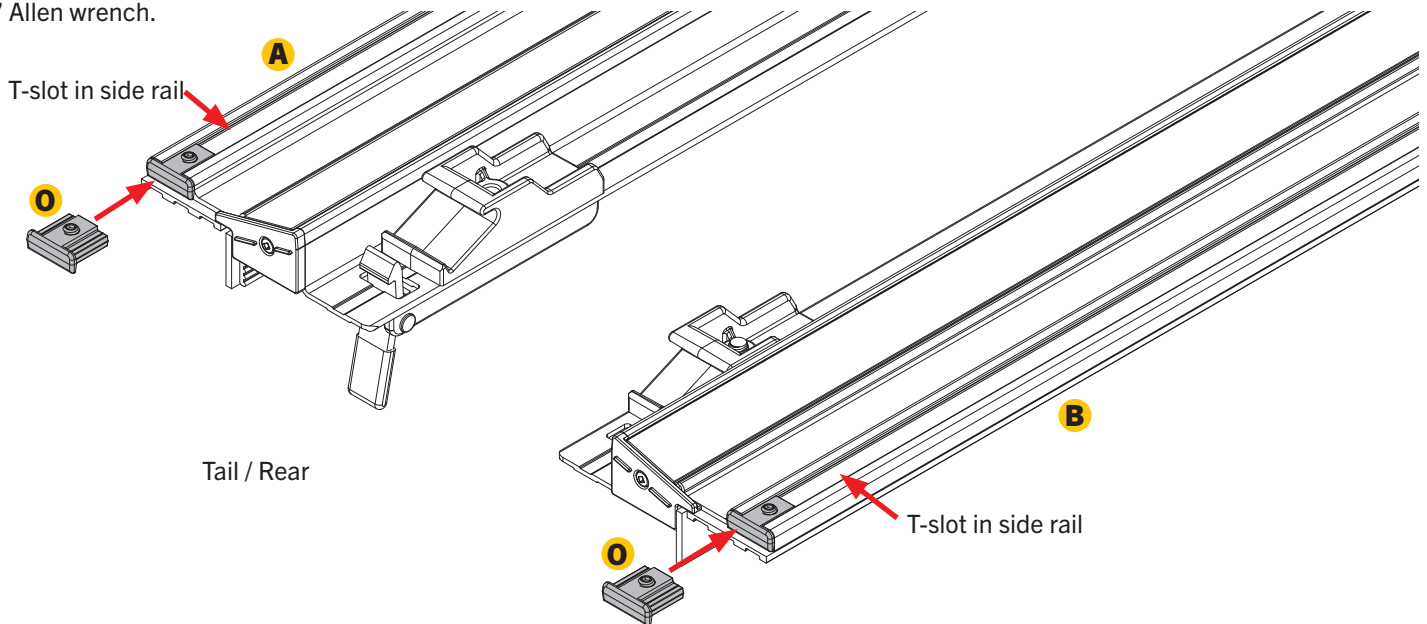

## OPENING THE COVER

To drive with the cover in the open position, pull the latch towards you to release the cover (located on driver side rail). Roll the cover toward the cab of the truck, making sure that both sides roll evenly. Secure the cover by placing both retainer hooks into the retainer loops. **You are ready to drive with the cover in the open position.**

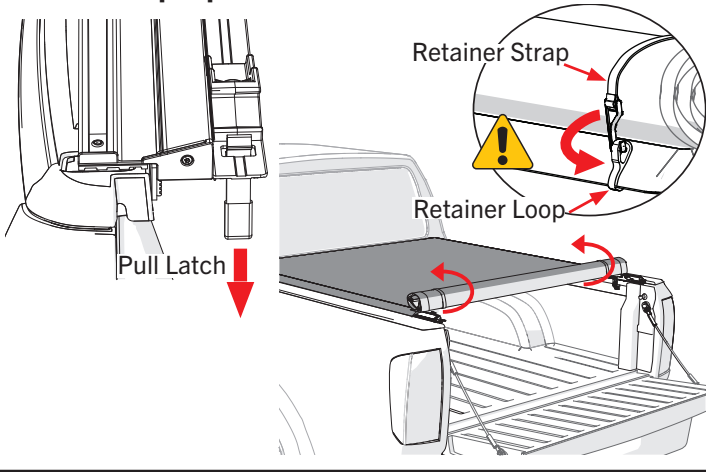

## REMOVING THE COVER

To remove the cover from the side rails, unfasten the hex nut (L) and washer (M) from underneath the side rails at the cab. Do this on both the driver and passenger side. Carefully lift the cover off the side rails.

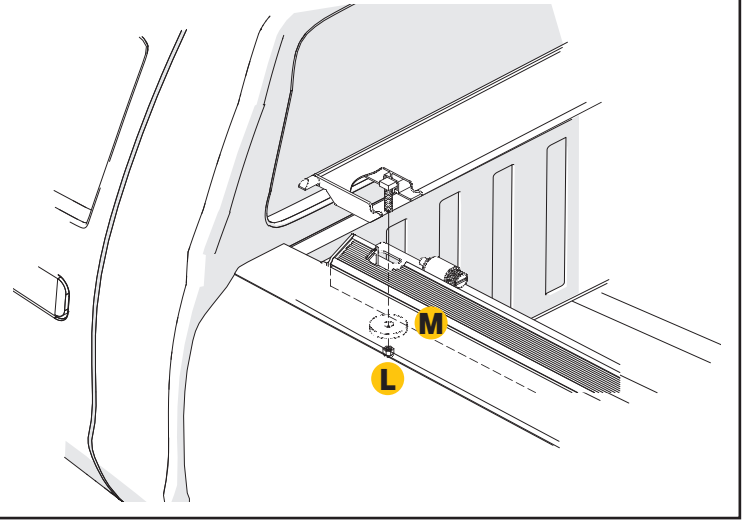

## AUTOMATIC TENSION CONTROL ADJUSTMENT

The cover is equipped with Automatic Tension Control. This helps compensate for material expansion and contraction caused by extreme temperature changes. Proper tension allows the cover to look and perform at its best. While preset at the factory, you can check cover tension after installation as well as seasonally.

If the cover feels too tight or too loose when opening or closing it, adjust the tension during the warmest part of the day. With the cover closed, release the hook and loop fastener from both side rails near the cab. Check compression of both spring plungers against the front header per Detail C. Roll the cover open and make adjustments. Repeat until satisfactory tension has been achieved.

### DETAIL C

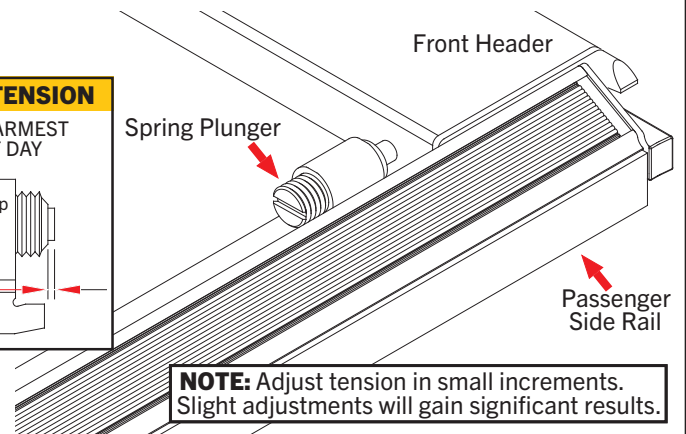
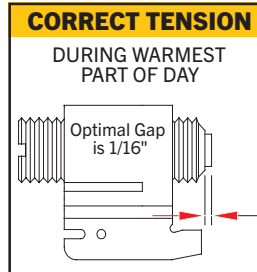
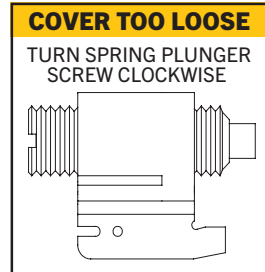

**NOTE:** Adjust tension in small increments. Slight adjustments will gain significant results.

# LIMITED LIFETIME WARRANTY

## WARRANTY COVERAGE

This truck bed cover is warranted against defects in materials or workmanship as follows. This warranty is void if the product has been damaged in an accident, or due to neglect, unforeseeable use, improper installation, improper servicing, or other cause not arising out of defects in material or workmanship.

### LIMITED LIFETIME WARRANTY ON HARD PARTS

All hardware included with your truck bed cover, including rails, clamps and bows carry a limited lifetime warranty, subject to the terms below.

### LIMITED LIFETIME WARRANTY FOR FABRIC

The fabric on your truck bed cover carries a limited lifetime warranty, subject to the terms below.

## WARRANTY IS NOT TRANSFERABLE

The warranty is to the initial consumer purchasing the truck bed cover and it is not transferrable to a subsequent end user. Proof of purchase may be required to enforce these warranty rights.

## WARRANTY CONDITIONS

Failure to follow these warnings and care instructions will void the warranty:

- Clean with mild automotive soap and water only.
- Do not use conditioners that contain silicone or petroleum.
- The tonneau cover must be secured at all points when the vehicle is in motion. When not fully closed with the rear latch engaged the cover must be completely rolled up and secured at the cab with both provided retainer straps attached. Do NOT drive with the bed cover in a partially open position.
- Cargo should not contact the tarp at any point. Protrusions in the tarp will stress the fabric. Cargo may also shift while traveling causing it to press against the fabric and damage it.
- Check rail clamps for tightness after a week of driving following the installation of the cover and periodically thereafter.
- Do NOT roll the cover into the rear cab window. Do NOT stow the cover against the cab of the truck.
- If the cover is going to be rolled open for an extended amount of time, periodically re-roll the cover and secure the retainer straps to ensure the cover doesn't rest against the cab of the truck.
- Before opening, the cover must be free of all foreign materials including snow and ice.
- Do NOT tow your vehicle from the rear with the cover on your vehicle. If towing from the rear is required, the cover MUST be removed from the vehicle and properly stored.

## WARRANTY PERFORMANCE

If all warranty conditions are met, a defective truck bed cover, tarp, or hardware component will either be repaired or replaced (at our option). We reserve the right, for any warranty, to substitute a newer model of bed cover having similar form and function, to offer a warranty discount on an entire replacement system, and/or provide remedies other than those mentioned in this document.

## WARRANTY PROCESS

A Return Material Authorization number must be obtained from our Customer Service Department prior to returning any product. We may require the original item to be returned postage prepaid for final determination. Shipping charges will apply for any repair or replacement. Other than postage or shipping charges, no charge will be made for repair or replacement under this warranty. This warranty gives you specific legal rights. As a consumer, you may also have additional rights and remedies under the laws of your state.

## WARRANTY REGISTRATION

Warranty registration must be on file and/or proof of original purchase (detailed and dated receipt) required for warranty to be effective.

Register online at <https://realtruck.com/truxedo-warranty/>

**REGISTER  
YOUR  
WARRANTY  
ONLINE**





## SAFETY INSTRUCTIONS

- DO NOT place objects on or against cover or framework.
- DO NOT tie cargo to truck bed cover framework.
- DO NOT attempt to drive with the cover in the partially open position.
- DO NOT operate vehicle with objects on top of the cover.
- NEVER allow children or pets to occupy pickup box while cover is closed.
- Cover is not airtight. Special care is required to keep cargo clean and dry.
- Tonneau covers won't prevent theft of contents inside truck box.
- The cover assembly (tarp) must be rolled fully open and secured with retainer straps when towing vehicle backwards.
- If the cover is going to be rolled open for an extended amount of time, periodically re-roll the cover and secure the retainer straps to ensure the cover doesn't rest against the cab of the truck.
- A fully rolled cover in the open position must always be secured with retainer straps.

## TROUBLESHOOTING TIPS

### WRINKLES ON THE FABRIC AFTER ROLLING COVER CLOSED

- Pull the fabric taut from each side. For best results, the help of a second person pulling on the opposite side is preferable.

### SAGGING FABRIC BETWEEN THE CROSS BOWS

- Adjustment to automatic tension control may be required.

### WIND LIFTS UP THE EDGE OF THE FABRIC

- Make sure to engage the hook and loop on the driver and passenger side rails after closing the cover. This may need to be done periodically when taking long trips.

### FABRIC FLUTTERS EXCESSIVELY WHEN DRIVING

- Check cover tension, refer to the Automatic Tension Control section.
- Make sure hook and loop fasteners are set. See Steps 18 - 19.

### SNOW AND ICE ACCUMULATION ON THE FABRIC

- Use broom or brush to remove loose snow and ice. DO NOT use sharp or pointed tools to remove snow and ice.
- Direct sunlight will help melt snow and ice off the fabric.

### TONNEAU COVER WILL NOT LATCH

- Check side rails to make sure they are level. See Step 9.
- Make sure the header seal is not caught between side rails & header.
- Check the position of side rails on the pickup box. They may be positioned too low. See Step 9.
- Make sure the cover has proper tension, refer to the Automatic Tension Control section.

### FABRIC IS TOO TIGHT OR TOO LOOSE

- See Automatic Tension Control section to adjust tension.

### FABRIC HAS SHIFTED TOO FAR TO ONE SIDE

- Unlatch the cover at the tailgate, release the hook and loop along both sides, go to the shorter side of the tarp and tug. The fabric will slide in the aluminum headers. Pull on the shorter side until the tarp appears centered on the whole system. Latch the cover and secure the hook and loop down both sides. Repeat if more adjustment is needed.

## COVER CARE AND MAINTENANCE

- Clean with soap and water. The cover can be treated with any vinyl protectant specifically made for tonneau covers.
- It is recommended that you periodically check that the cover is securely attached to your truck bed. Inspect the clamps and front header guide slides to ensure they were properly installed and have not come loose during operation.
- It is recommended that you periodically inspect and service the rear latch closure. Clean away any excess dirt or grime.
- Covers that are used frequently or are subject to vibrations and impacts from rough roadways may require adjustment.

## FAQ

### WHY IS THERE A HOLE PUNCHED AT THE REAR OF THE PASSENGER SIDE RAIL OF THE TRUXEDO LO PRO, DEUCE, PRO X15 AND PRO X15 TS BUT NO LATCH?

All side rails are punched identically to keep them uniform, to ensure manufacturing efficiency and to reduce tooling costs. By doing this, TruXedo can build and ship more covers while maintaining competitively priced products of the highest quality.

### WHY IS MY COVER HOLDING WATER AFTER IT RAINS?

Water pooling on the cover is normal because our cross bows are not arched. Since they are designed to sit flat some water may accumulate on the top of the cover. Once you drive your truck, the water will shed from the cover. Make sure to retighten the hook and loop fasteners along the length of the bed.

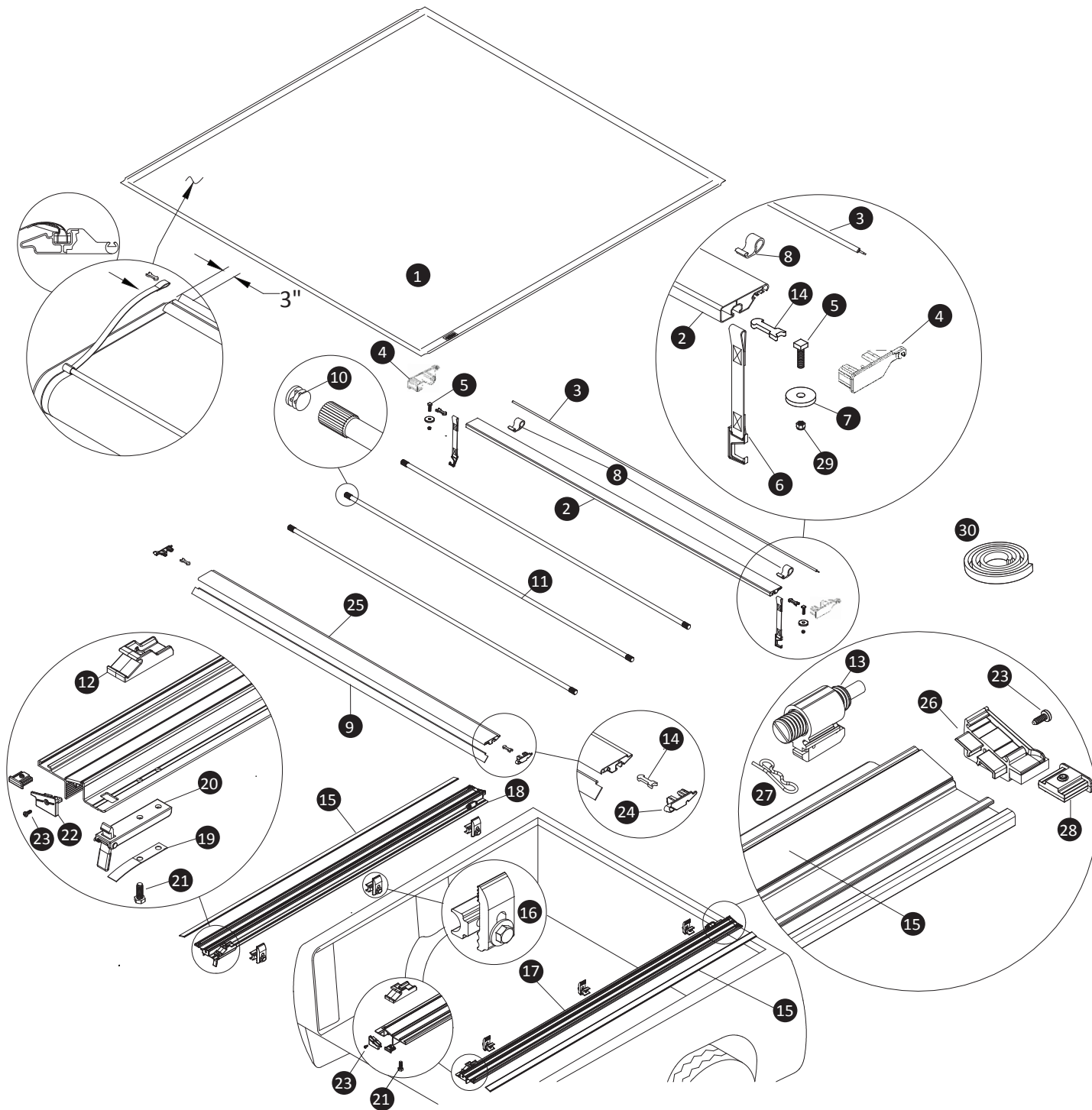

### Replacement Parts

1	*	TruXedo Pro X15 TS Replacement Cover	11	*	Aluminum Cross Tubes	21	1702926	Cap Screw, 5/16" x 7/8"
2	*	Black Front Header	12	1704187	Header Stop	22	1118700	Rear Side Rail End Plugs w/Seal ProX15 (Set of Two)
3	*	Header Seal Front	13	1115356	Tension Control Housing & Spring Tension	23	1706547	Square Head Screw (#1 Drive)
4	1118915	Front Header End Plugs (Set of Two)	14	1705787	Header Insert Retainer Clip	24	1117467	Rear Header End Plugs Pro X15 (Set of Two)
5	1703455	Sq. Hd. Cap Screw 3/8" x 1 1/2"	15	*	Hook and Loop Fasteners	25	*	Black Rear Header
6	*	Retainer Strap	16	1706843	Aluminum Clamp Single (1)	26	1118701	Front Side Rail End Plugs w/Seal ProX15 (Set of Two)
7	1117594	Washer Plastic 1/4" x 1.50 Dia.	17	*	Pro X15 TS Rail, Passenger's Side	27	1707003	Bow Tie Hitch Pin
8	*	Extruded Retainer Loop	18	*	Pro X15 TS Rail, Driver's Side	28	1707322	Pro X15 TS End Plugs (Set of Four)
9	*	Header Seal Rear	19	1705727	Flat Spring, 5/8" x 3 7/8"	29	1701580	Hex Lock Nut, 3/8"-16
						30	1118237	Bulkhead Seal

\* Please specify length or make and model of vehicle.