

PARTS LIST:

1	Bull Bar	4	10-1.50mm x 30mm Hex Bolts
1	Driver/Left Frame Bracket	8	10mm x 27mm OD x 3mm Flat Washers
1	Passenger/Right Frame Bracket	4	10mm Lock Washers
1	Driver/Left Bull Bar Bracket	4	10mm Hex Nuts
1	Passenger/Right Bull Bar Bracket	4	8-1.25mm x 35mm Hex Bolts
2	Light Brackets	4	8mm x 24mm OD x 2mm Flat Washers
4	12-1.75mm x 35mm Hex Bolts	4	8mm Lock Washers
8	12mm x 32mm OD x 3mm Flat Washers	4	6-1.0mm x 20mm Button Head Bolts
4	12mm Lock Washers	4	6mm Lock washers
4	12mm Hex Nuts	4	6mm x 18mm OD x 1.6mm Flat Washers

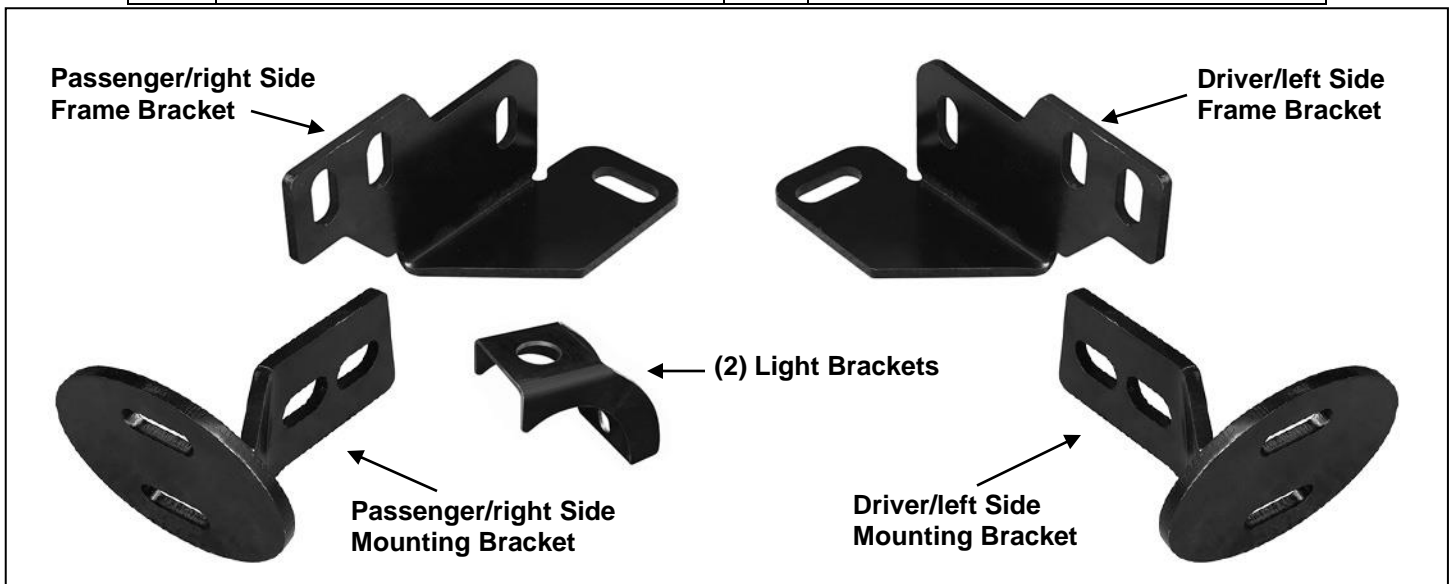

PROCEDURE:

- 1. REMOVE CONTENTS FROM BOX. VERIFY ALL PARTS ARE PRESENT. READ INSTRUCTIONS CAREFULLY BEFORE STARTING INSTALLATION. CUTTING MAY BE REQUIRED.**
- 2. NOTE:** It may be necessary to remove/relocate front license plate and license plate bracket. It is not required, but strongly recommended. If local/state law requires a license plate, license plate relocation kit is available.
- From under the front of the vehicle, remove the two bolts holding the driver side tow hook in place in the end of the frame. Remove tow hook from vehicle, **(Figure 1)**. **NOTE:** This Bull Bar is not compatible with factory tow hooks and they cannot be reinstalled. **IMPORTANT:** It may be necessary to trim the opening in the bumper cover slightly for Bracket clearance.
On models without tow hooks, the pocket in the plastic bumper cover will need to be cut out to clear the Brackets, **(Figure 2)**.
- Select the driver side Frame Bracket, **(Figure 3)**. Position the Bracket up to the outside of the frame with mounting holes lined up with the holes for the tow hook. Bolt the Bracket to the frame with the included (2) 12mm x 35mm Hex Bolts, (4) 12mm Flat Washers, (2) 12mm Lock Washers and (2) 12mm Hex Nuts, **(Figures 4 & 5)**. Do not tighten at this time.

3-1/2" OVAL BULL BAR
07-10 CHEVY SILVERADO 25-3500/GMC SIERRA 25-3500

5. Select the driver side Bull Bar Mounting Bracket, **(Figure 6)**. Attach the Bracket to the inside of the Frame Bracket with the included (2) 10mm x 30mm Hex Bolts, (4) 10mm Flat Washers, (2) 10mm Lock Washers and (2) 10mm Hex Nuts, **(Figure 7)**. Do not tighten hardware at this time.
6. Repeat **Steps 3—6** to install the passenger side Frame Bracket and Bull Bar Mounting Bracket.
7. With assistance, position the Bull Bar up to the end of the (2) Mounting Brackets. Bolt the Bull Bar to the Mounting Brackets with the included (4) 8mm x 35mm Hex Bolts, (4) 8mm Lock Washers and (4) 8mm Flat Washers, **(Figure 8)**. Do not tighten at this time.
8. Level and adjust the Bull Bar and tighten all hardware. **NOTE:** If you can't reach the Bull Bar Bolts, (8mm hardware), from behind of bumper and through tow hook opening, some trimming to the opening might be necessary to access the Bull Bar Bolts, **(Figure 7)**.
9. If not installing lights at this time, use the included (4) 6mm Button Head Bolts, (4) 6mm Lock Washers and (4) 6mm Flat Washers to plug the (4) threaded holes in the back of the cross bar, **(Figure 9)**.
10. If aftermarket lights, (not included), are to be installed, remove the rubber plugs on the top of the cross bar. Select (1) Light Bracket, **(Figure 10)**. Attach the light to the Light Bracket using the hardware included with the light. Attach the light and Bracket to the back of the Bull Bar with (2) 6mm Button Head Bolts, (2) 6mm Lock Washers and (2) 6mm Flat Washers, **(Figure 11)**. Adjust the light as desired. **NOTE:** Depending on light design, repeated removal and reinstallation of the light and Bracket may be required for proper adjustment. Tighten all hardware.
11. Repeat **Step 10** to install the second light.
12. Do periodic inspections to the installation to make sure that all hardware is secure and tight.

To protect your investment, wax this product after installing. Regular waxing is recommended to add a protective layer over the finish. Do not use any type of polish or wax that may contain abrasives that could damage the finish.

For stainless steel: Aluminum polish may be used to polish small scratches and scuffs on the finish. Mild soap may be used also to clean the Bull Bar.

For gloss black finishes: Mild soap may be used to clean the Bull Bar.

Driver Side Installation Pictured

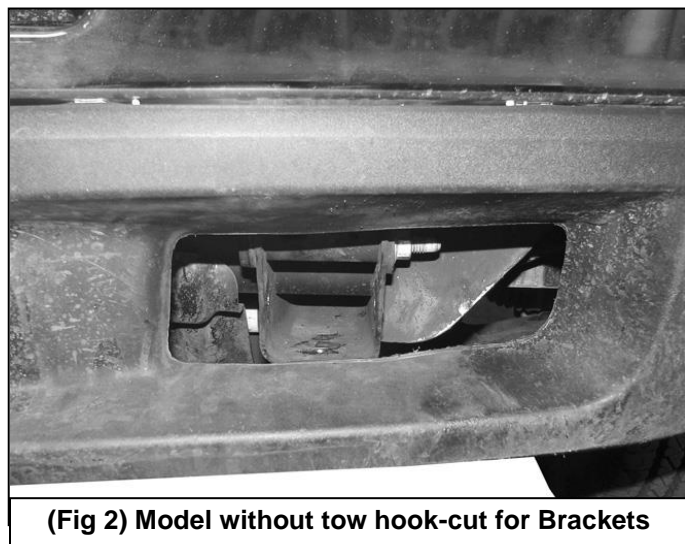
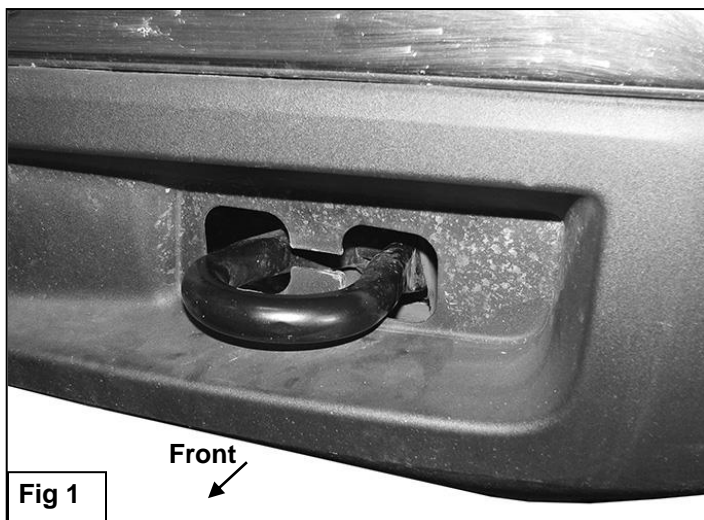

3-1/2" OVAL BULL BAR
07-10 CHEVY SILVERADO 25-3500/GMC SIERRA 25-3500
Driver Side Installation Pictured

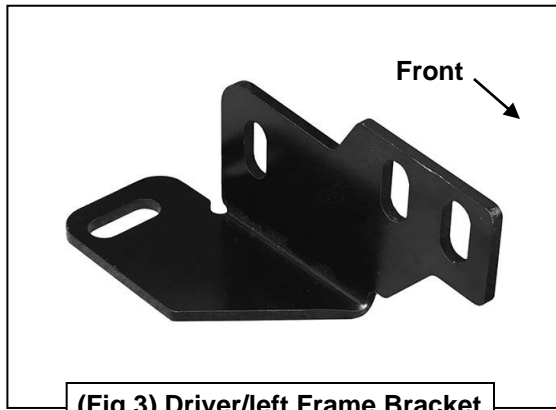

(Fig 3) Driver/left Frame Bracket

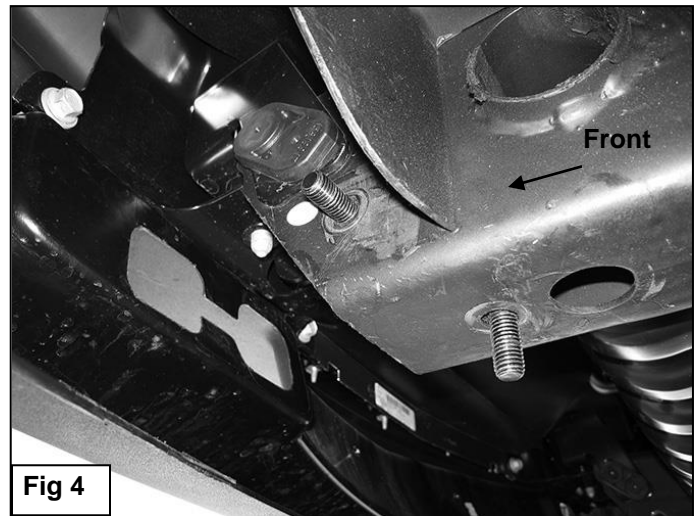

Fig 4

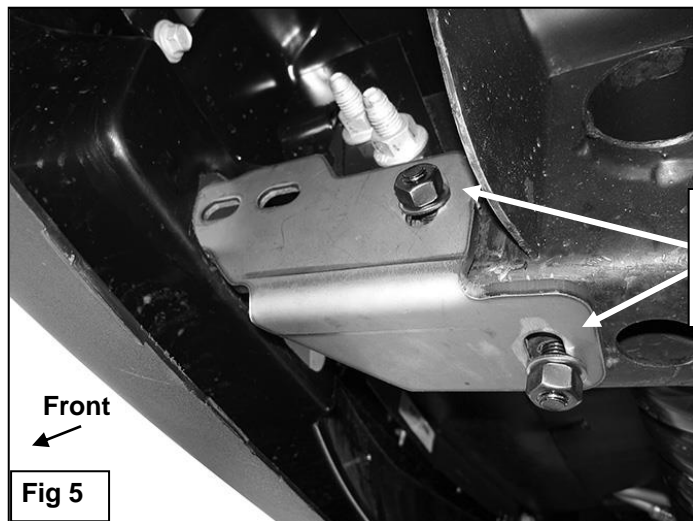
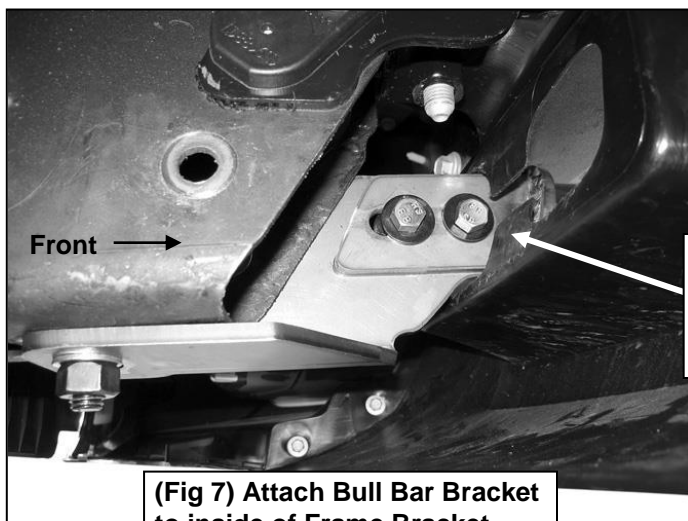

Fig 5

- (2) 12mm x 35mm Hex Bolts
- (4) 12mm Flat Washers
- (2) 12mm Lock Washers
- (2) 12mm Hex Nuts



(Fig 6) Driver/left Bull Bar Mounting Bracket



(Fig 7) Attach Bull Bar Bracket to inside of Frame Bracket

- (2) 10mm x 30mm Hex Bolts
- (4) 10mm Flat Washers
- (2) 10mm Lock Washers
- (2) 10mm Hex Nuts

3-1/2" OVAL BULL BAR
07-10 CHEVY SILVERADO 25-3500/GMC SIERRA 25-3500

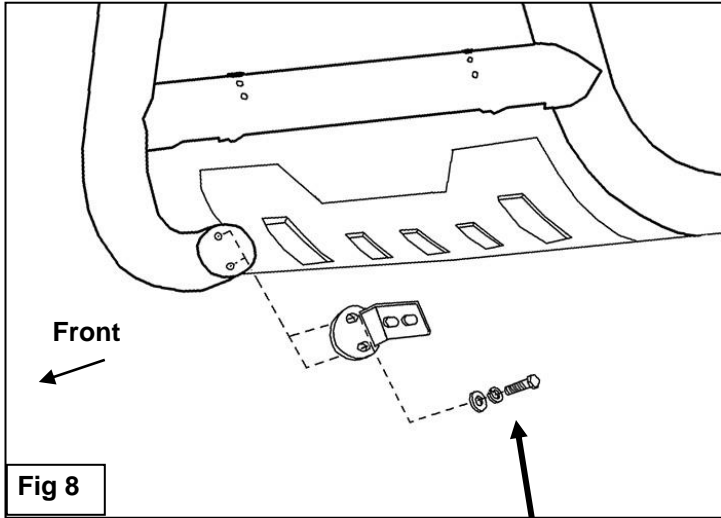

- (2) 8mm x 35mm Hex Bolts
- (2) 8mm Lock Washers
- (2) 8mm Flat Washers

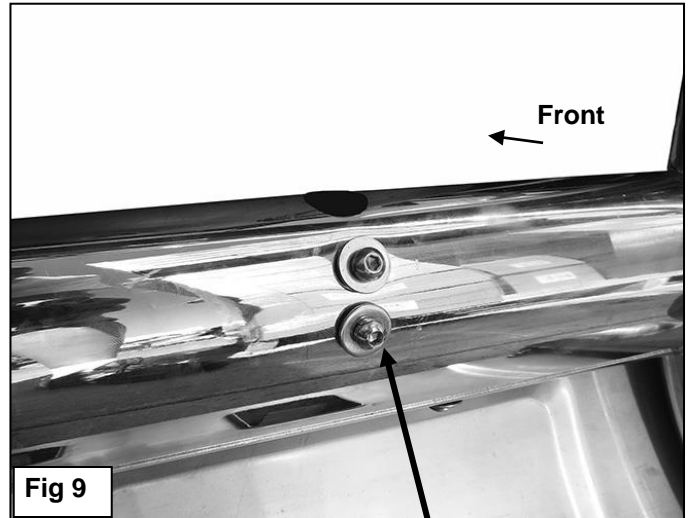

- (2) 6mm Button Head Bolts
- (2) 6mm Lock Washers
- (2) 6mm Flat Washers

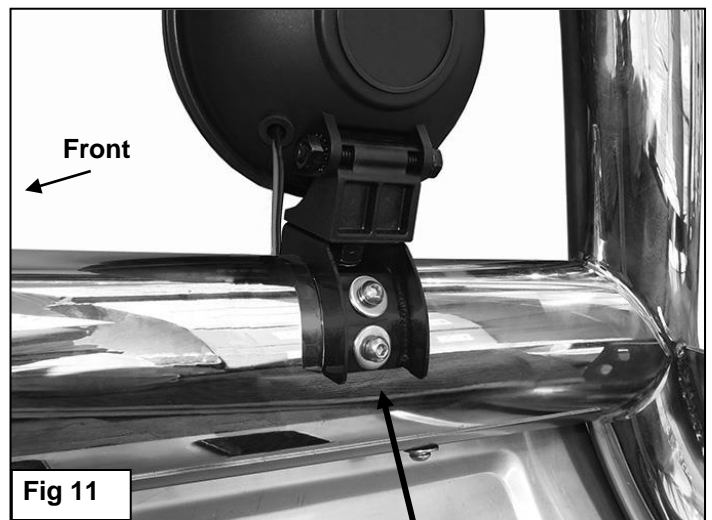
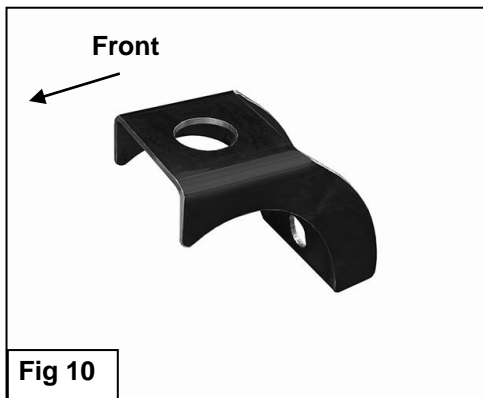

- (2) 6mm Button Head Bolts
- (2) 6mm Lock Washers
- (2) 6mm Flat Washers

