

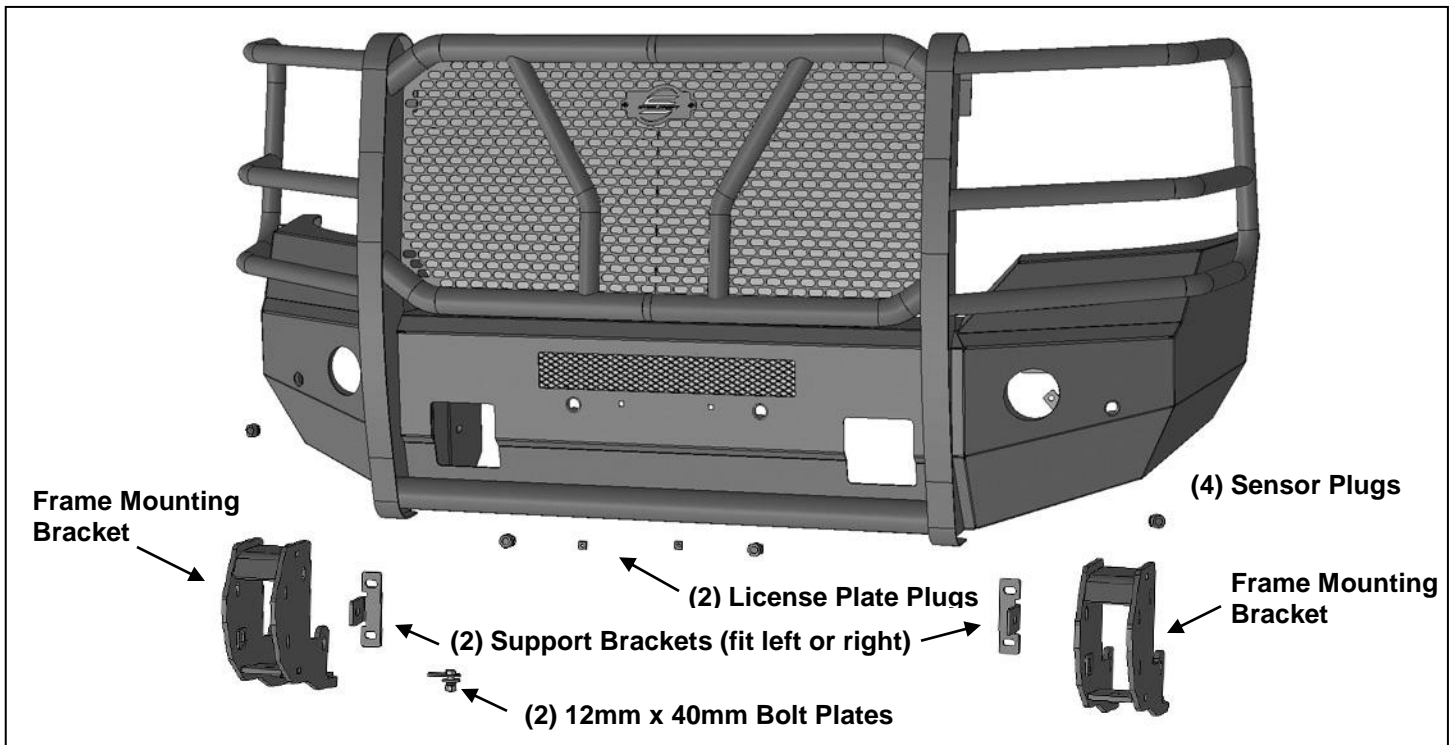

ELEVATION FRONT BUMPER 2015-17 GMC SIERRA 25-3500

PARTS LIST:

1	Elevation Front bumper	6	12-1.75mm x 160mm Hex Bolts
2	Frame Mounting Brackets (fit left or right)	2	12-1.75mm x 50mm Hex Bolts
2	Support Brackets (fit left or right)	18	12mm x 37mm OD x 3mm Flat Washers
4	Sensor Plugs	10	12mm Lock Washers
1	Sensor Cover Kit	10	12mm Hex Nuts
2	Plastic Plugs for License Plate	8	4mm x 10mm Button Head Screws
2	12mm Bolt Plates	1	2.5mm Wrench



PROCEDURE:

REMOVE CONTENTS FROM BOX. VERIFY ALL PARTS ARE PRESENT. READ INSTRUCTIONS CAREFULLY BEFORE STARTING INSTALLATION. BUMPER IS HEAVY, ASSISTANCE IS HIGHLY RECOMMENDED TO AVOID POSSIBLE INJURY OR DAMAGE TO THE VEHICLE.

1. Remove the license plate and bracket. On models with factory fog lights and/or bumper sensors, unplug the wiring harness leading to the front bumper and move it out of the way, **(Figure 1)**.
2. Remove the bumper supports running from the outside of the frame to the outer ends of the bumper.
3. Open the hood and remove the plastic cover from the top of the radiator, **(Figure 2)**. Temporarily remove the plastic grille, **(Figure 3)**.
4. Place blocks or jack stands under the front bumper to support it during mounting bolt removal. Once the bumper has been safely supported, from above the bumper, remove the (2) factory bumper bolts from each side, **(Figure 4)**. **WARNING!** Assistance is required to hold the bumper in place during bolt removal to prevent the bumper from falling. Carefully slide the bumper off of the end of the frame and tow hooks.
5. Remove the factory bumper brackets and tow hooks from the ends of frame, **(Figure 5)**.
6. Select (1) Frame Mounting Bracket. Attach the Bracket to the end of the driver/left end of the frame with the included (1) 12mm x 160mm Hex Bolt, (2) 12mm Flat Washers, (1) 12mm Lock Washer and (1) 12mm Hex Nut, **(Figures 6 & 9)**. Next, attach the bottom of the Frame Bracket to the bottom of the frame with (1) 12mm Bolt Plate, (1) 12mm Flat Washer, (1) 12mm Lock Washer and (1) 12mm Hex Nut, **(Figures 6 & 9)**. **NOTE:** Insert the Bolt Plate into the end of the frame and down through the bottom of the Frame and through the Bracket. Do not fully tighten hardware at this time.
7. Next, select (1) Support Bracket, **(Figure 7)**. Reuse (2) factory bumper bracket bolts to attach the Support Bracket to the mounting plate on the end of the frame, **(Figures 7 & 8)**. Do not attach the

**ELEVATION FRONT BUMPER
2015-17 GMC SIERRA 25-3500**

Support Bracket to the side of the Frame Bracket at this time, (See **Step 11A**). Do not fully tighten hardware at this time.

8. Repeat **Steps 6 & 7** to install the passenger side Frame Bracket, Support Bracket, (**Figure 9**).
9. Determine if the vehicle is equipped with bumper sensors. It may be easier or necessary to install the sensors before installing the Bumper.

Models without bumper sensors:

- a. Select the included (4) Rubber Plugs.
- b. From behind bumper, push plugs into sensor mounting holes, (**Figure 10**).

Models with bumper mounted sensors:

- a. Push the sensor into the mounting socket in the back of the bumper.
- b. Secure each sensor to the socket with (2) 4mm x 10mm Button Head Screws, (**Figure 10**).
IMPORTANT: Sensors fit snug in sockets. The 4mm Screws are used to apply slight pressure to lock the sensors in place. Tighten both screws evenly until they touch the sensor body only. Make sure sensor is in the center of the mounting sleeve and flush with the outside of the bumper. It may be necessary to remove the plastic tab from the side of the sensor to fit into the mount sleeve. Do not overtighten screws or damage to sensors may result.

10. With assistance, position the Bumper Assembly up to and over the Brackets. Temporarily support the weight of the Bumper. **WARNING:** To avoid possible injury or damage to the vehicle, do not proceed until the Bumper is fully and safely supported.
11. Line up the (3) holes in the driver side mounting plate on the back of the Bumper with the (3) slots in the Frame Bracket. Attach the Bumper to the top inner mounting hole in the Bracket with (1) 12mm x 160mm Hex Bolt, (2) 12mm Flat Washers, (1) 12mm Lock Washer and (1) 12mm Hex Nut, (**Figures 11—13**). **NOTE:** Top Bolt will also attach Support Bracket to inside of Frame Bracket. Repeat to attach the passenger side of the Bumper to the Bracket.
12. Next, from in front of the Bumper, insert (1) 12mm x 50mm Hex Bolt, (2) 12mm Flat Washers, ((1) 12mm Lock Washer and (1) 12mm Hex Nut through the tow hook opening and out the slot in the outside of the Bracket, (**Figures 11A & 11B**). Repeat this **Step** to attach the passenger side of the Bumper to the Frame Bracket.
13. Select (1) factory tow hook if equipped. Insert the tow hook into the opening in the driver side Frame Bracket, (**Figure 12**). Reuse the short factory tow hook hex bolt to attach the tow hook to the bottom plate on the Bracket. Insert (1) 12mm x 160mm Hex Bolt, (2) 12mm Flat Washers, (1) 12mm Lock Washer and (1) 12mm Hex Nut, through the Bumper Bracket and tow hook, (**Figures 12 & 13**). Leave tow hook hardware loose at this time. Repeat this **Step** to install the passenger side tow hook.
14. Level and adjust the Bumper and fully tighten all hardware to 65-70ft-lbs.
15. **Models with fog lights and/or bumper sensors:**
 - a. Slide the driver side light into place through the opening in the bumper, (**Figure 14**). Carefully push the attaching posts into the tabs on the bumper, (**Figure 15**). Repeat this **Step** to install passenger/right side light.
16. Reattach the factory wiring harness to both lights and/or sensors if equipped.
17. Use the included (2) push-in Plastic Nuts to attach the front license plate, (if required), to the (2) holes in the front Bumper, (**Figure 16**).
18. Do periodic inspections to the installation to make sure that all hardware is secure and tight.

To protect your investment, wax this product after installing. Regular waxing is recommended to add a protective layer over the finish. Do not use any type of polish or wax that may contain abrasives that could damage the finish. Mild soap may be used to clean the Front Bumper assembly.

Driver/left Side Installation Pictured

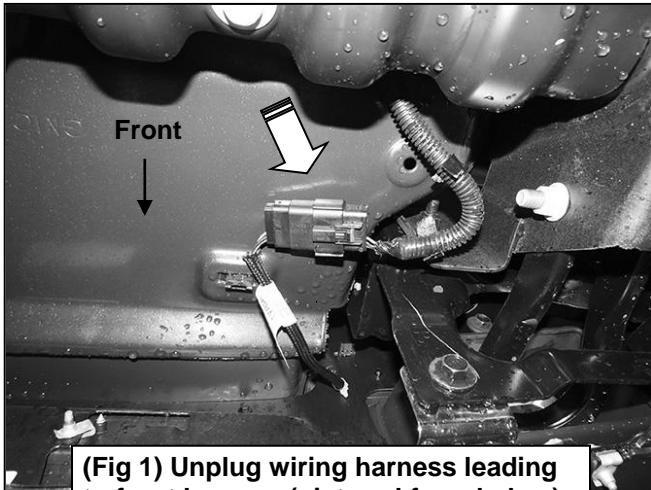

(Fig 1) Unplug wiring harness leading to front bumper (pictured from below)

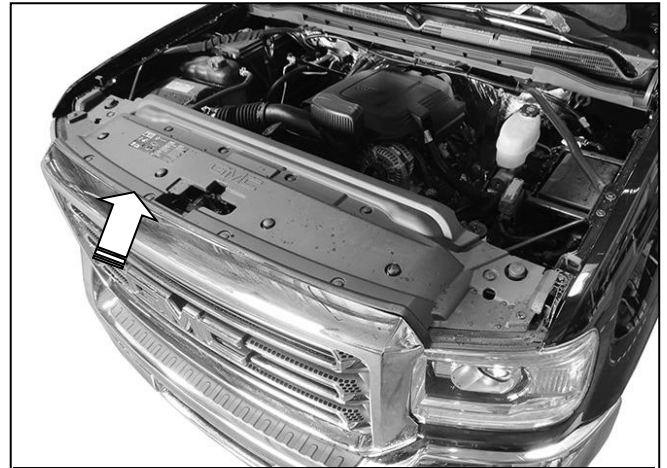

(Fig 2) Remove plastic cover from top of radiator

WARNING! Do not remove bumper bolts unless the bumper is properly supported on blocks or stands or the bumper may fall.

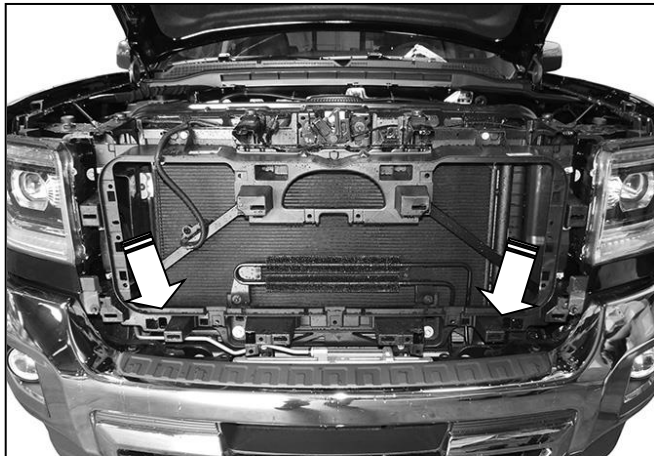

(Fig 3) Remove grille to access bumper bolts (Fig 4)

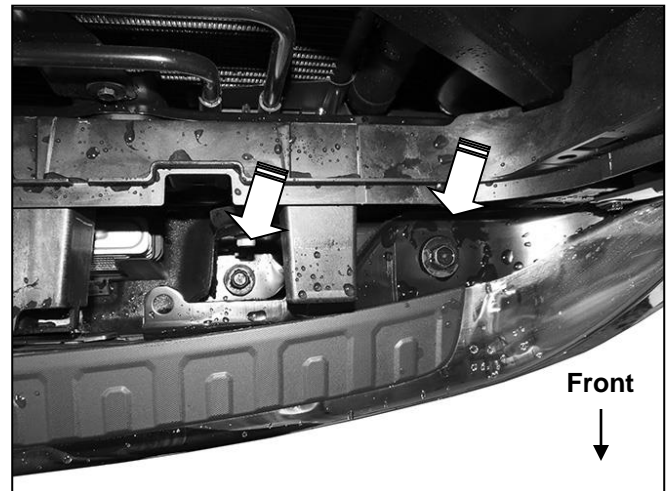

(Fig 4) Remove outer bumper supports attached to frame and ends of the bumper. Remove bumper bolts (arrows) to remove bumper (driver side pictured from above).

WARNING! Do not crawl under bumper unless the bumper is properly supported on blocks or stands or the bumper may fall.

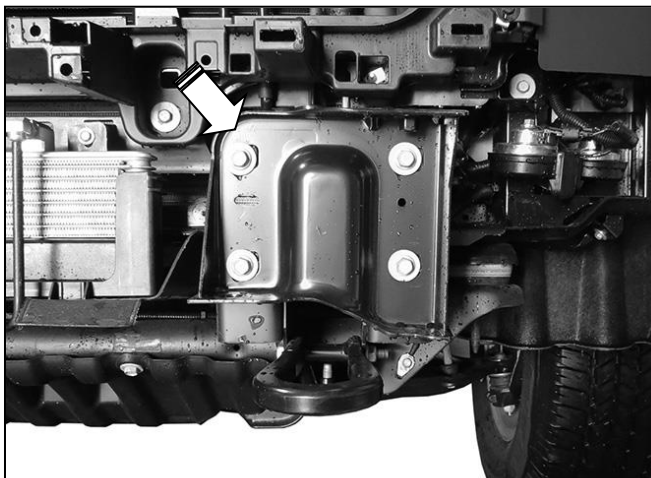

(Fig 5) Remove bumper brackets and tow hooks

Driver Side Installation Pictured

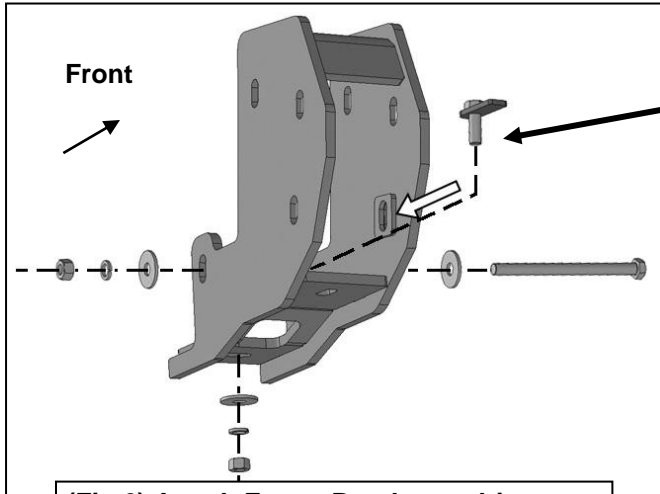

12mm Bolt Plate
12mm Flat Washer
12mm Lock Washer
12mm Hex Nut

12mm x 160mm Hex Bolt
(2) 12mm Flat Washers
12mm Lock Washer
12mm Hex Nut

(Fig 6) Attach Frame Bracket to driver side of frame. Insert 12mm Bolt Plate down through hole in bottom of the frame

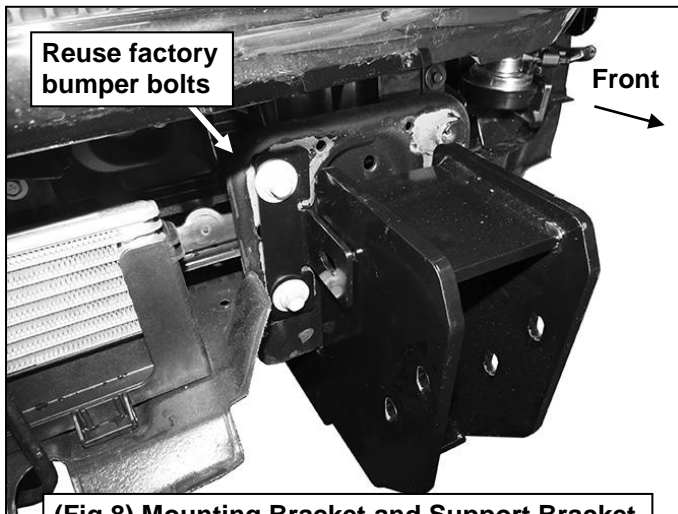

Reuse factory bumper bolts

(Fig 8) Mounting Bracket and Support Bracket

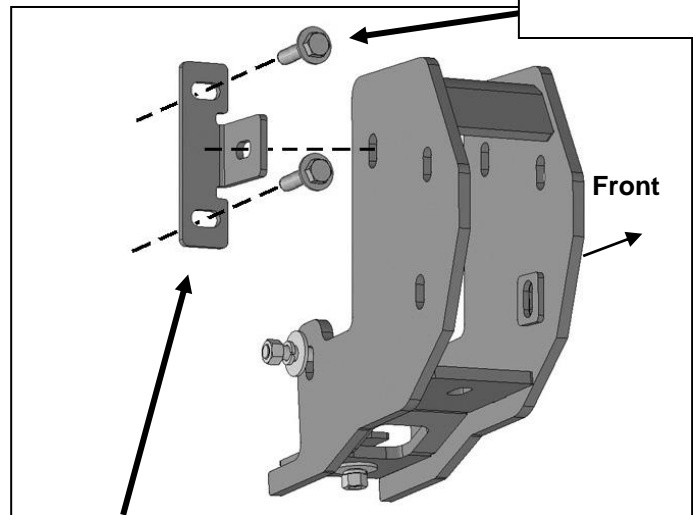

(Fig 7) Reuse factory bumper bolts to attach Support Bracket to bumper/frame mounting plate

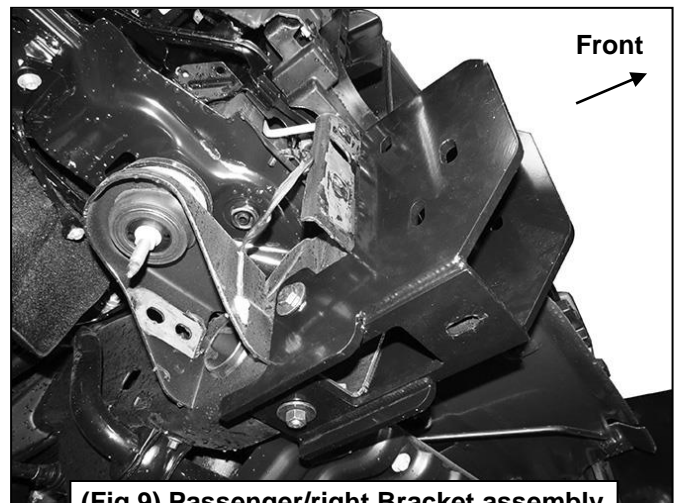

(Fig 9) Passenger/right Bracket assembly

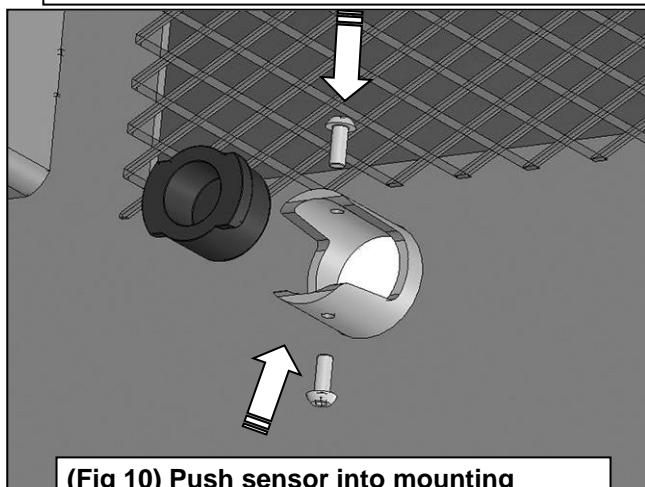

(Fig 10) Push sensor into mounting sleeve. Use 4mm Screws to lock sensor

IMPORTANT: Sensors fit snug in sockets. The 4mm Screws are only used to apply slight pressure to lock the sensors in place. Tighten both screws evenly until they touch the sensor body only. Do not overtighten screws or damage to sensors will result.

Driver side installation pictured

12mm x 50mm Hex Bolt
(2) 12mm Flat Washers
12mm Lock Washer
12mm Hex Nut

WARNING! Do not crawl under bumper unless the bumper is properly supported on blocks or stands or the bumper may fall.

12mm x 160mm Hex Bolt
(2) 12mm Flat Washers
12mm Lock Washer
12mm Hex Nut

12mm x 50mm Hex Bolt
(2) 12mm Flat Washers
12mm Lock Washer
12mm Hex Nut

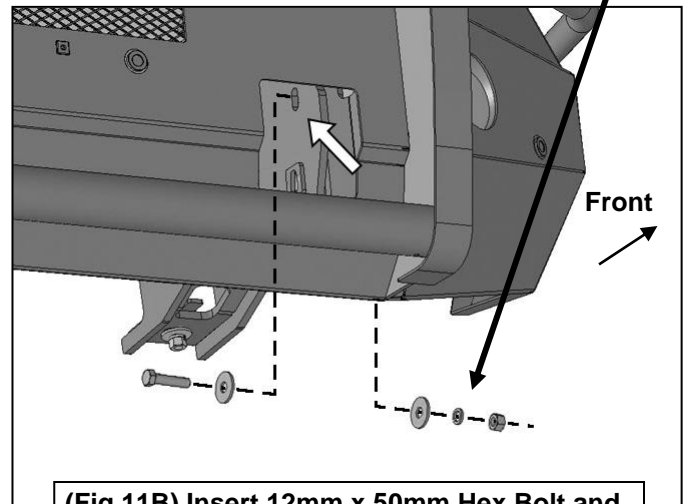
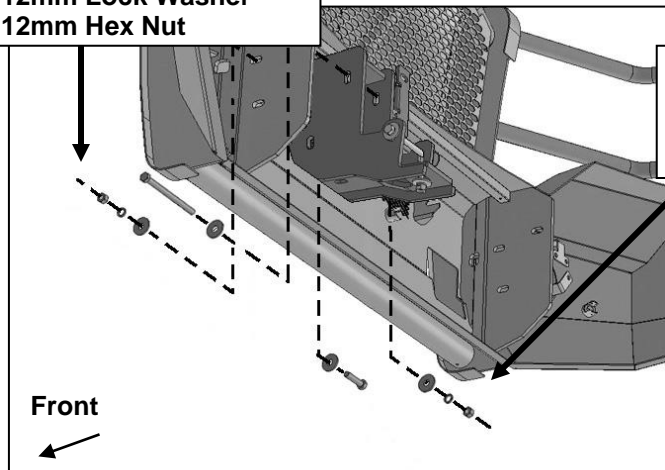

(Fig 11A) Insert long 12mm x 160mm Hex Bolt and Flat Washer into top slot in Bumper and through Bracket. Back of driver side of Bumper illustrated

(Fig 11B) Insert 12mm x 50mm Hex Bolt and Flat Washer into opening for tow hook and out through inside slot in top of Bracket. Front of driver side of Bumper illustrated

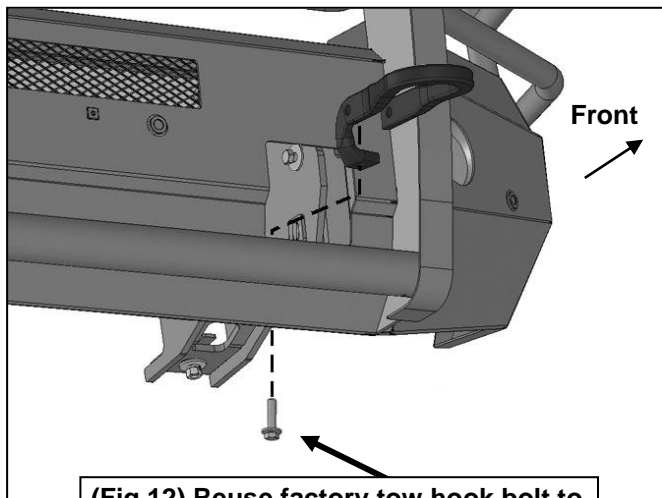

(Fig 12) Reuse factory tow hook bolt to attach tow hook to bottom of Bracket

12mm x 160mm Hex Bolt
(2) 12mm Flat Washers
12mm Lock Washer
12mm Hex Nut

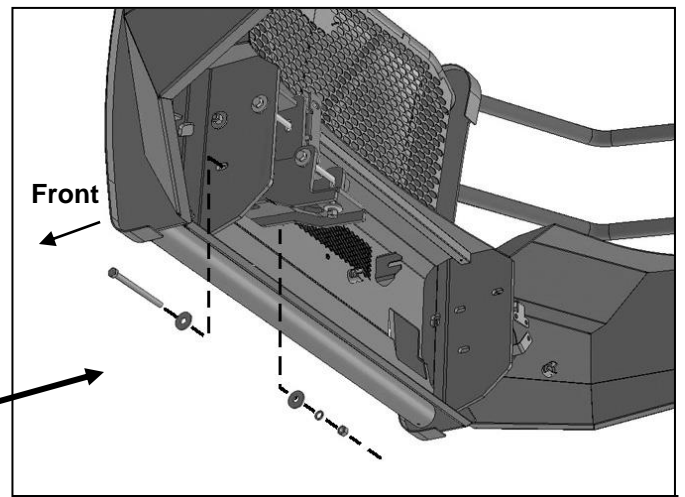

(Fig 13) Insert long 12mm x 160mm Hex Bolt with Flat Washer through Bumper, Bracket and tow hook. Back of driver side of Bumper illustrated

WARNING! Do not crawl under bumper unless the bumper is properly supported on blocks or stands or the bumper may fall.

Driver side installation pictured



(Fig 14) Factory fog light

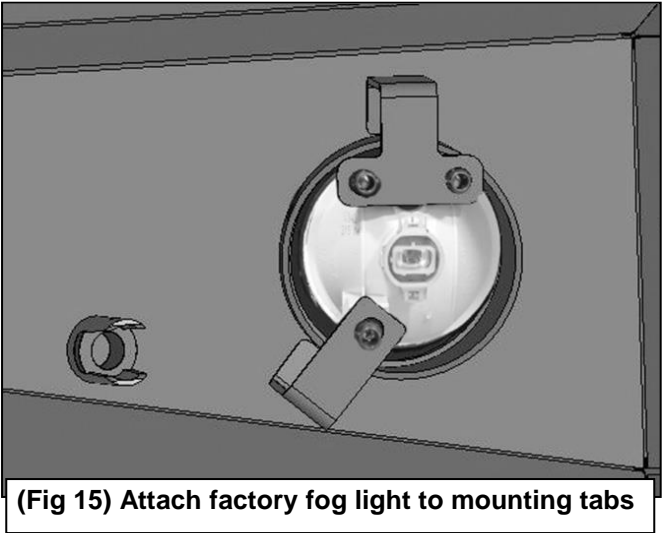

(Fig 15) Attach factory fog light to mounting tabs

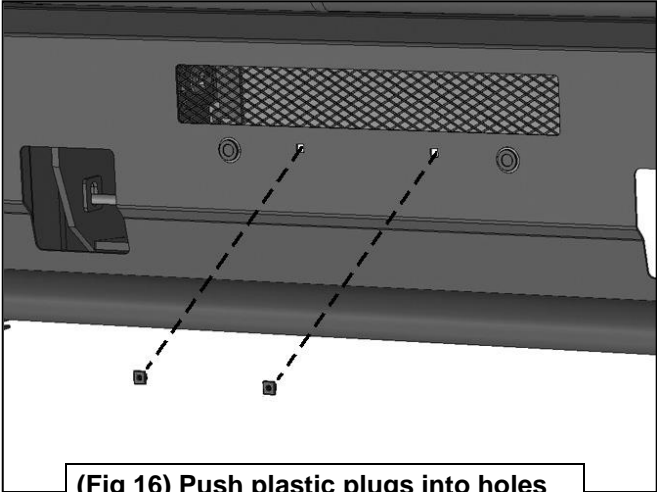

(Fig 16) Push plastic plugs into holes in Bumper for license plate if required

