

PARTS LIST:

1	Extreme Grille Guard	16	12mm x 32mm OD x 3mm Flat Washers
1	Driver/Left Top Mounting Bracket	10	12mm Lock Washers
1	Passenger/Right Top Mounting Bracket	10	12mm Hex Nuts
1	Driver/Left Frame Mounting Bracket	2	10-1.5mm x 40mm Hex Bolts
1	Passenger/Right Frame Mounting Bracket	4	10mm x 27mm OD x 3mm Flat Washers
4	12-1.75mm x 60mm Gr. 10.9 Hex Bolts	2	10mm Lock Washers
6	12-1.75mm x 35mm Gr. 10.9 Hex Bolts	2	10mm Hex Nuts
4	12mm x 24mm OD x 2.5mm Flat Washers		

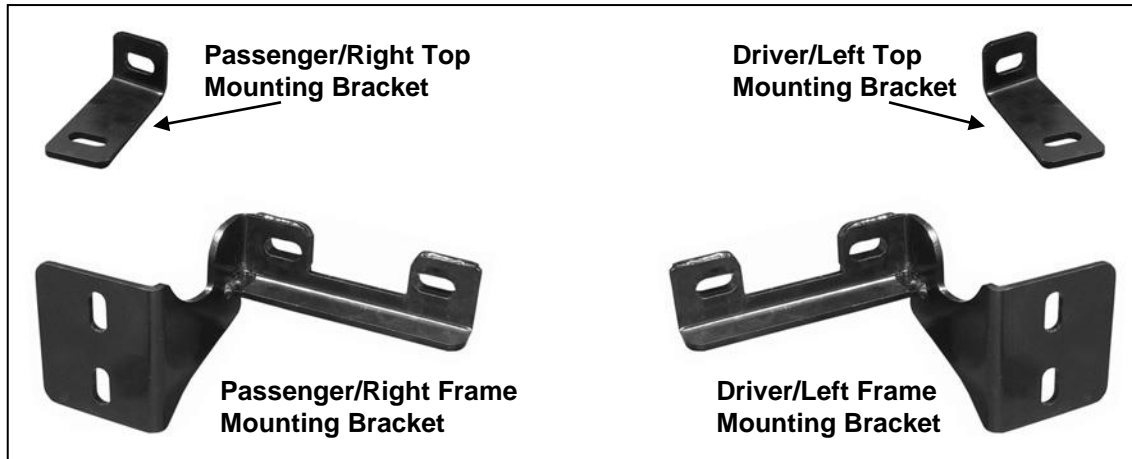

PROCEDURE:

- 1. REMOVE CONTENTS FROM BOX. VERIFY ALL PARTS ARE PRESENT. READ INSTRUCTIONS CAREFULLY BEFORE STARTING INSTALLATION. ASSISTANCE IS RECOMMENDED.**
- Determine if the vehicle is equipped with or without the factory tow hooks.

On vehicles without factory tow hooks: Remove the plastic fill panel on the front bumper by removing the 2-piece plastic clips at the top of the panel, **(Figure 1A)**. **NOTE:** Use a flat-blade screwdriver to first pop the center pin out to release the clip, **(Figure 1B)**. Next, from behind the driver side of the front bumper, remove the (2) hex nuts on the bottom of the bumper bracket securing the bumper to the frame, **(Figure 2)**.

On vehicles with factory tow hooks: Start the installation on the driver side, behind the front bumper. Remove the factory tow hook, **(Figure 3)**. Remove the two hex nuts on the bottom of the bumper bracket securing the 2-bolt tow hook mounting bracket to the frame.
- Next, drive the (2) carriage bolts in the bumper bracket out of the bracket by striking the end of the bolts with a hammer, **(Figure 4)**. Discard the tin retaining washers. Insert the driver side Mounting Bracket into the opening in the front of the bumper and line up the (2) mounting holes with the holes in the bumper bracket. Insert (2) 12mm x 60mm Hex Bolts and (2) 12mm x 32mm OD Large Flat Washers through the driver side Frame Mounting Bracket and bumper bracket. Use the supplied (2) 12mm x 24mm Flat Washers, (2) 12mm Lock Washers and (2) 12mm Hex Nuts, **(Figure 5)**. Snug but do not tighten hardware.

On vehicles with factory tow hooks: Reinstall the factory 2-bolt tow hook bracket and secure with the supplied (2) 12mm x 24mm Flat Washers, (2) 12mm Lock Washers and (2) 12mm Hex Nuts. Snug but do not tighten hardware at this time. Reinstall the tow hook using the factory hardware.

**EXTREME GRILLE GUARD
09-10 DODGE RAM 1500**

- Carefully pull up on the plastic bumper cover, (on top of the bumper), to locate the carriage bolt securing the top of the steel bumper to the inner bumper bracket. Remove the carriage bolt, **(Figure 7)**. **NOTE:** The hex nut on the carriage bolt can be removed from behind the bumper by inserting a socket and extension through the space above the factory bumper bracket, **(Figure 6)**. Bolt the driver side Top Mounting Bracket to the bumper by inserting (1) 10mm x 40mm Hex Bolt and (1) 10mm Flat Washer through the Bracket and hole in the bumper, **(Figure 8)**. Secure with (1) 10mm Flat Washer, (1) 10mm Lock Washer and (1) 10mm Hex Nut. Do not tighten hardware at this time.
- Repeat Steps 2 - 4 for passenger side Mounting Bracket installation.
- With assistance, position the Grille Guard up to the Frame Mounting Brackets and on top of the Top Mounting Brackets. Use the included (4) 12mm x 35mm Hex Bolts, (8) 12mm Flat Washers, (4) 12mm Lock Washers and (4) 12mm Hex Nuts to attach the Grille Guard to the Frame Mounting Brackets, **(Figure 9)**. Snug but do not tighten at this time.
- Align the holes and attach the Grille Guard to the Top Mounting Brackets using the included (2) 12mm x 35mm Hex Bolts, (4) 12mm Flat Washers, (2) 12mm Lock Washers and (2) 12mm Hex Nuts, **(Figures 9)**. Snug but do not tighten hardware at this time.
- With assistance, align and adjust the Grille Guard and tighten all hardware, including the Top Mounting Bracket and tow hook hardware. **On vehicles without factory tow hooks:** The plastic fill panel in the front bumper removed in **Step 2** may be discarded or can be reinstalled but will require cutting to clear the Frame Mounting Brackets. Once modified, use the factory hardware to reinstall.
- Do periodic inspections to the installation to make sure that all hardware is secure and tight.

To protect your investment, wax this product after installing. Regular waxing is recommended to add a protective layer over the finish. Do not use any type of polish or wax that may contain abrasives that could damage the finish.

For stainless steel: Aluminum polish may be used to polish small scratches and scuffs on the finish. Mild soap may be used also to clean the Grille Guard.

For gloss black finishes: Mild soap may be used to clean the Grille Guard

Driver Side Installation Pictured

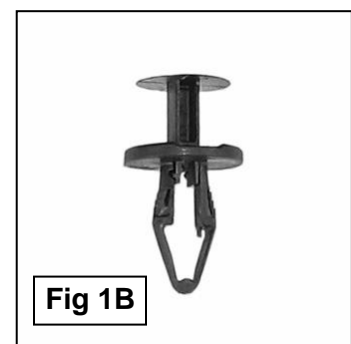
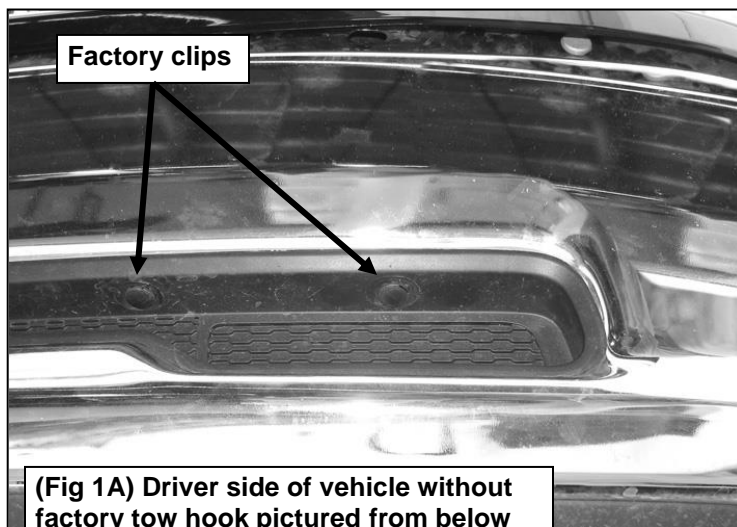

Pry up center pin with a flat blade screwdriver to release factory clip. Remove entire clip

Driver Side Installation Pictured

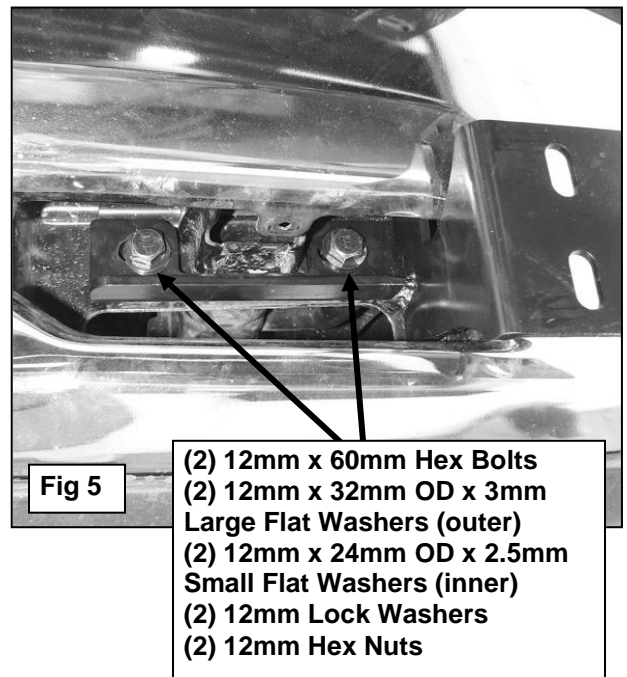
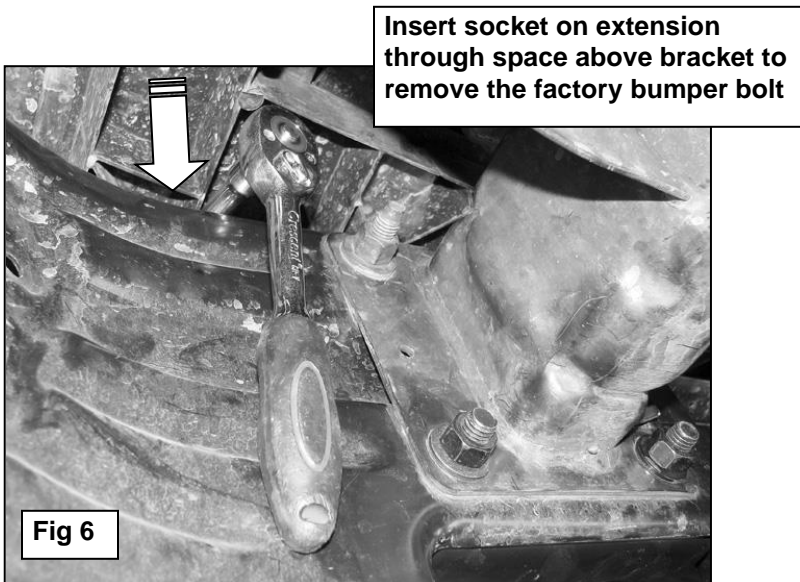
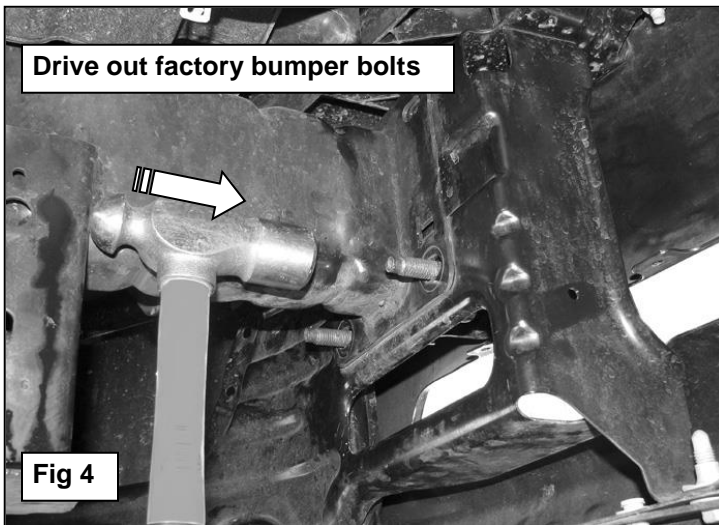
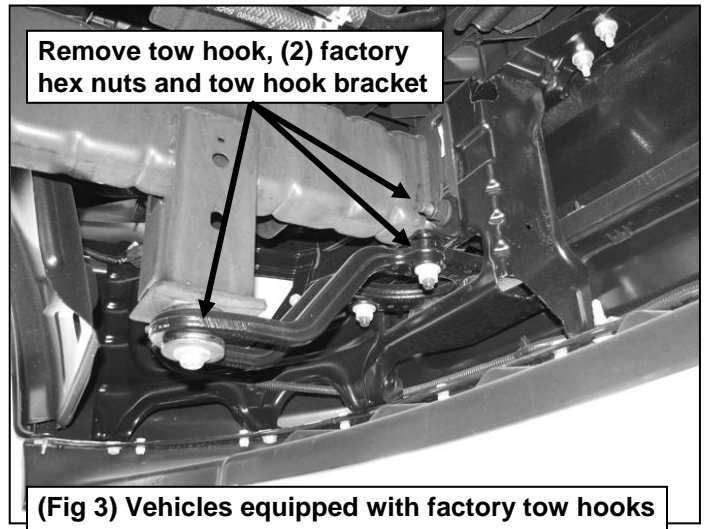
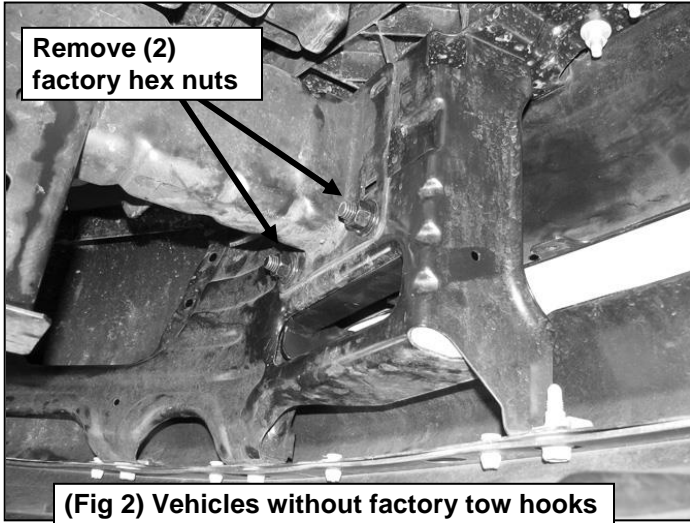

**EXTREME GRILLE GUARD
09-10 DODGE RAM 1500**

Driver Side Installation Pictured

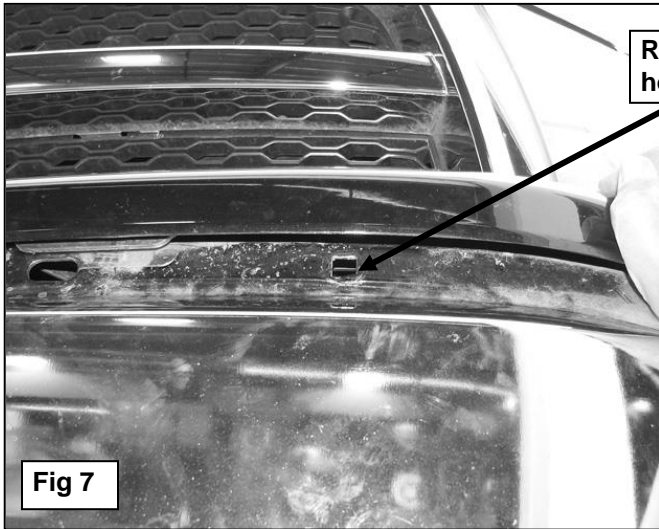

Raise plastic cover to access mounting hole (factory bumper bolt removed)

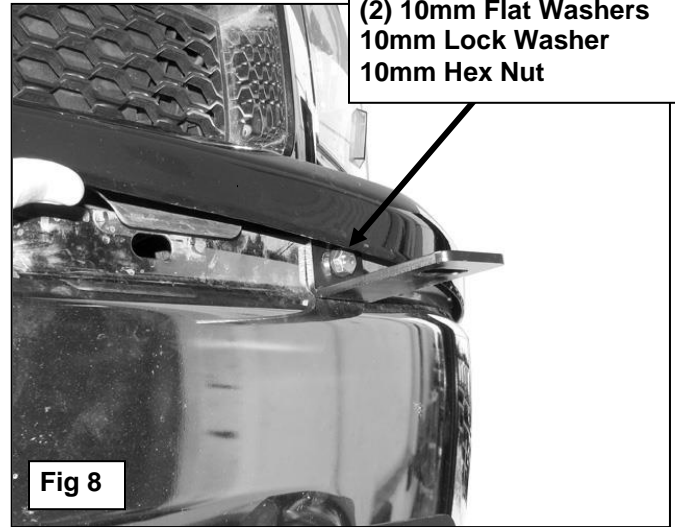

**10mm x 40mm Hex Bolt
(2) 10mm Flat Washers
10mm Lock Washer
10mm Hex Nut**

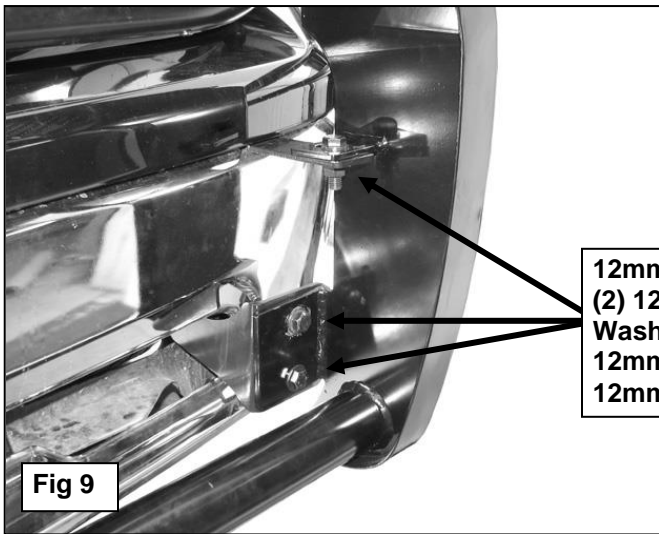

**12mm x 35mm Hex Bolt
(2) 12mm Large Flat Washers
12mm Lock Washer
12mm Hex Nut**

