

TOOLS REQUIRED

- 8mm socket
- 1/2" socket
- T30 Torx Bit
- T40 Torx Bit
- Driver / ratchet

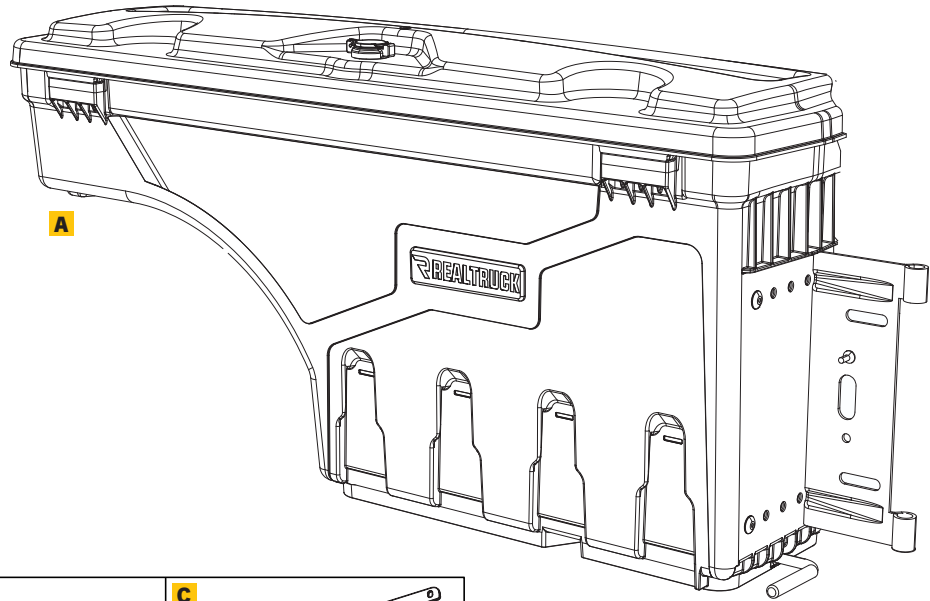

PARTS INCLUDED IN THE BOX

- A** 1x SwingCase
- B** 1x Truck bracket assembly
- C** 1x Striker bracket assembly
- D** 2x Keys
- E** 1x Pivot lock
- F** 2x Spacer
- G** 1x Flat washer 5/16"
- H** 3x Button head screw T40
- I** 3x Lock washer
- J** 3x Hex nut
- K** 4x Pan head screw T30

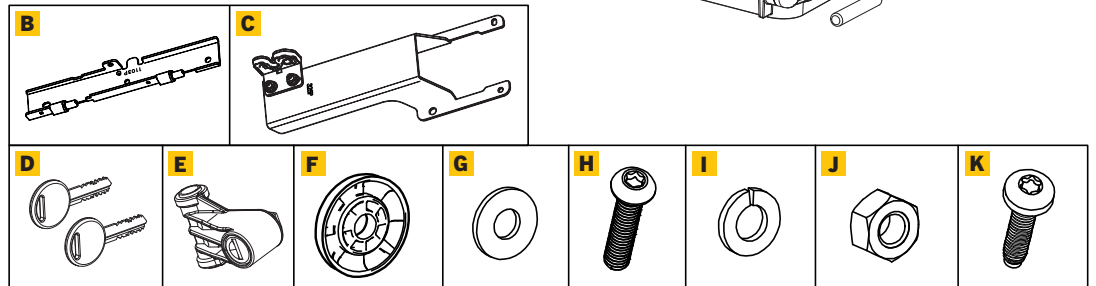

1 TRUCK BRACKET INSTALLATION - Line up the truck bracket according to the drawing.

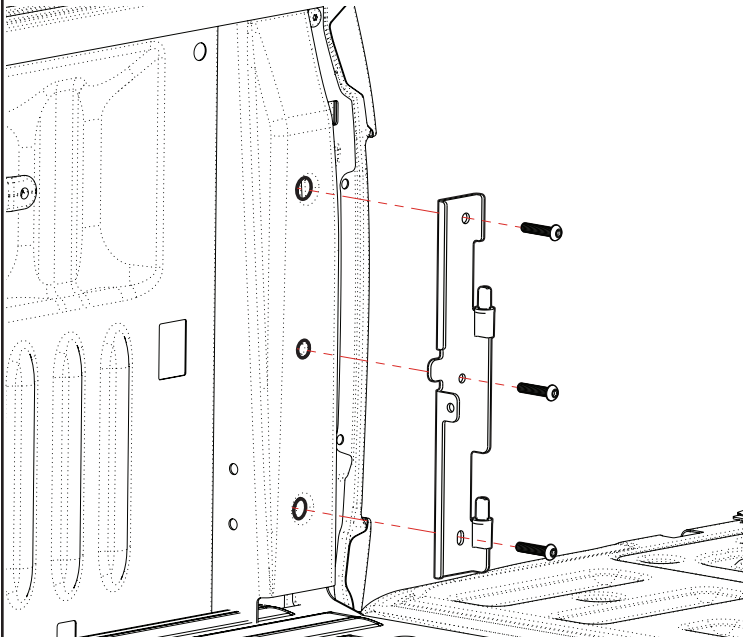

2 TRUCK BRACKET INSTALLATION - Attach the bracket to the truck. Starting with the middle hole, insert a torx bolt through the truck bracket and the truck, place flat washer, lock washer and assembly nut on bolt and hand tighten only. Use a torx bolt on the top hole followed by an aluminum spacer, lock washer and assembly nut (Note: the spacer should be positioned with the grooves against the truck bed). Do not tighten at this time. Repeat this procedure for the bottom hole and tighten all three.

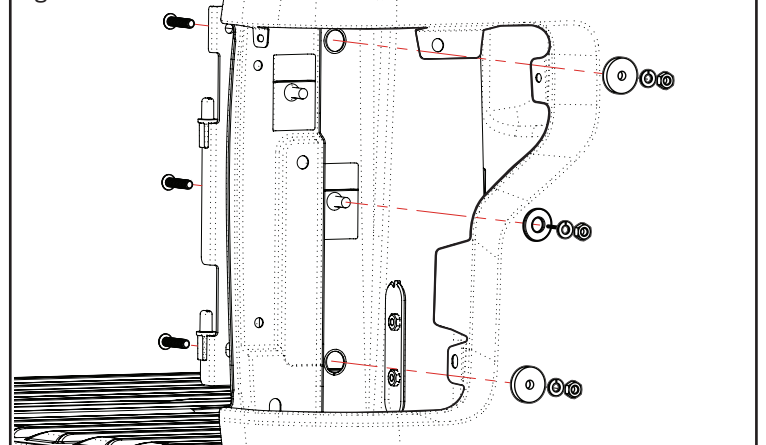

3 STRIKER BRACKET INSTALLATION - Remove the four (4) T30 torx bolts from the Box Link Plate. Using the existing hardware, install the striker bracket over the top of the Box Link plate (Note: The tie down can remain attached to the plate). Reinstall the taillight. If truck does not have the factory Box Link Plate/Tie down plate, use the 4 supplied T30 Torx bolts to install into the 4 factory self-threading inserts using a cordless impact driver/drill.

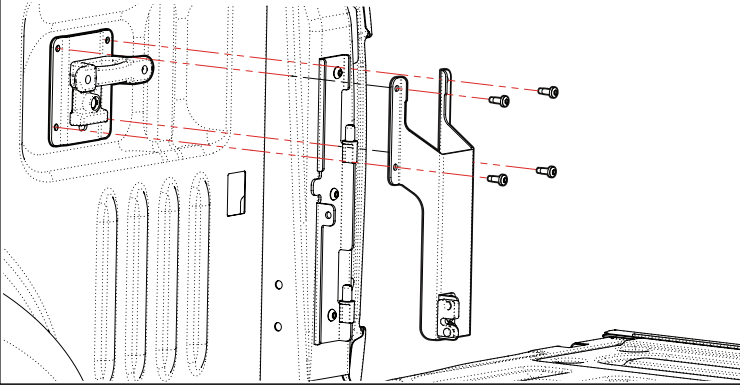

4 INSTALLING SWING CASE - Lower the box onto the hinge pins and gently push the box to the stowed position.

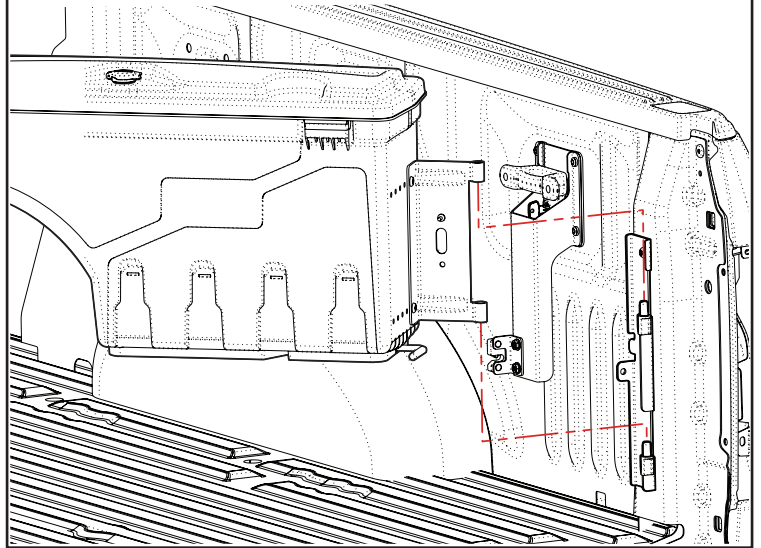

5 OPERATION AND ADJUSTMENT - Pull the latch rod and swing through the full motion making sure it operates freely and latches easily. Do not slam the box to stow it, if it will not latch easily it may be necessary to make some minor adjustments. The latch has slotted holes, just loosen the two bolts and adjust as needed.

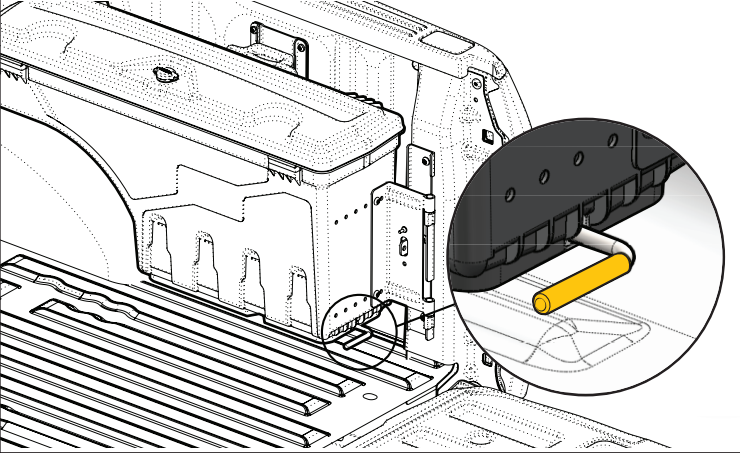

6 Insert the supplied pivot lock (E) at an angle between the lower tab and the top of the lower pivot bushing. While pushing upward on the pivot lock, rotate the pivot lock into position over the top of the lower pivot bushing.

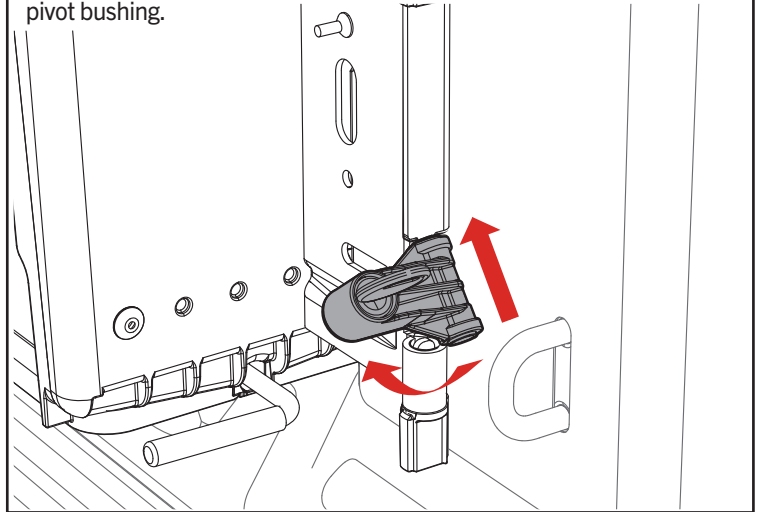

7 Once the pivot lock (E) is over the top of the lower pivot bushing, slide the pivot lock down against the top of the pivot bushing.

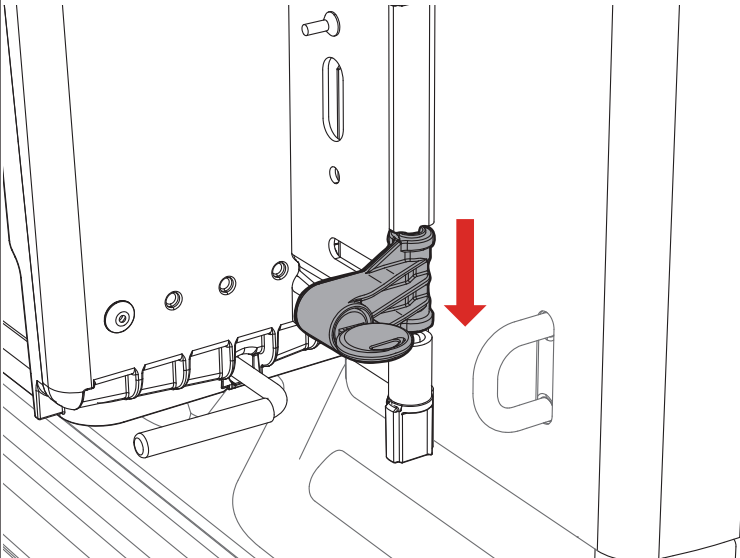

8 Rotate the pivot lock (E) towards the box bracket, so that the pivot lock is against the bracket and lines up with the slotted hole in the bracket.

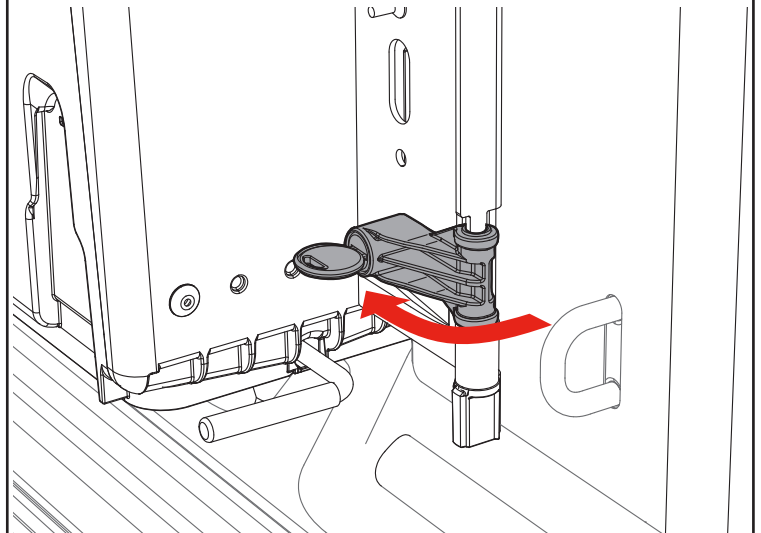

- 9** Rotate the key (F) 90 degrees into the locked position. **NOTE: Once the pivot lock is in the locked position, it will allow the user to still pull the release handle and swing the case out over the tailgate. The pivot lock will prevent the case from being fully removed.**

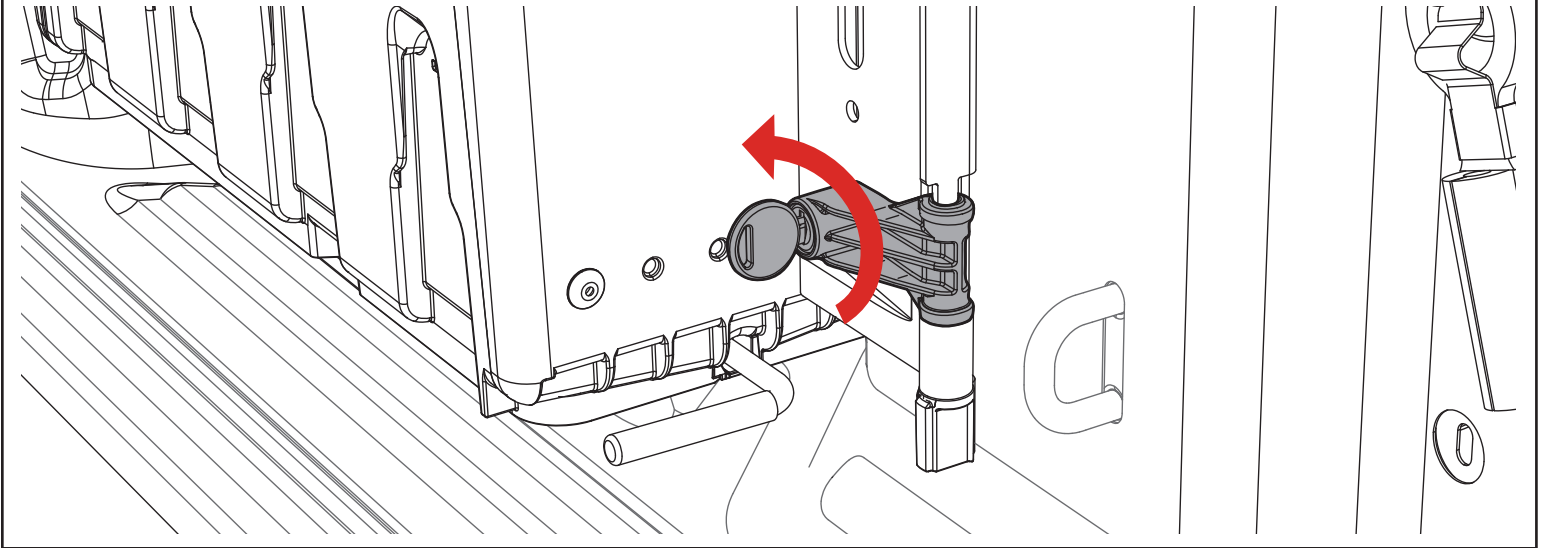

CARE AND MAINTENANCE

The ABS polymer body of your SwingCase requires only periodic cleaning with mild car wash soap. **ONLY USE CLEANERS, WAXES OR PRODUCTS THAT ARE LABELED "Safe for use on plastics"**. Do not let chemicals or substances come into contact with your SwingCase unless labeled "safe for plastics". Avoid the use of all abrasive type cleaners as they may dull the finish. Be sure that insecticides do not get onto the SwingCase from contact with your hands or other parts of your body. This could cause serious damage and discoloration.

INSTALLATION GUIDELINES

- The SwingCase is designed for trucks that do not have a bedliner (spray in bedliners pose no problem). Trucks that do have plastic drop-in bedliners or BedRugs will require some trimming of the liner to ensure proper fit of the brackets. We provide some guidelines for installing with liners, however, due to the wide variety of liner manufacturers, the modifications will vary. Any modifications must be made to the liner and **NOT** to the SwingCase mounting hardware. Modifications to the mounting hardware could result in improper installation and will void your warranty.
- The SwingCase will not work with bed extenders.
- The SwingCase will work with most tonneau covers. If you have questions regarding your installation, please contact customer service.

SAFETY INSTRUCTIONS

- **Warning:** Chemicals that are NOT labeled safe for use with plastics should **NOT** be stored in the SwingCase. Some chemicals such as insect repellents, brake fluid, and solvents can potentially damage the plastic. Doing so may void the warranty.

LIMITED WARRANTY

TERMS OF THIS WARRANTY

The manufacturer warrants that the ABS polymer structure of your SwingCase will be structurally free from defects in material and workmanship for (1) one year from the retail date of purchase. The lock, hinges, and hardware are warranted to be free from defects in material and workmanship for (1) one year from the retail date of purchase. This warranty applies only to the original purchaser and is nontransferable. Your original sales receipt will serve as proof of purchase for this warranty. Be sure to retain your receipt for your proof of purchase date. Before credit can be issued on a warranty claim, proof of defect may be required. This can be determined at the time of the claim.

EXCLUSIONS OF THIS WARRANTY

Not covered under this warranty is failure due to neglect, improper installation, including any modifications to installation hardware, alterations, addition of equipment, abuse, accident, weather related damage, exposure to chemicals that are not labeled “safe for plastics”, and normal wear from lack of maintenance.

CAUTION

Always read the ingredients of any product you are using to clean your SwingCase. Make sure that you use only products that are safe for use with plastics. Many chemicals contain material that will permanently discolor your SwingCase. This is not considered a manufacturer defect.

OWNER RESPONSIBILITIES

Incidental or consequential damage or loss of contents due to use, neglect, lack of maintenance, misuse, or abuse of the SwingCase is the sole responsibility of the truck owner and operator. Paint damage to your truck is not covered under this warranty. When operating your truck always keep the SwingCase in the stowed position with the lid closed and latched.

REPAIR AND REPLACEMENT

In the event that your SwingCase is found to be defective under the terms of this warranty, it is at the manufacturers discretion to repair or replace the defective part. All repairs must be made by an authorized SwingCase dealer or under the direction by the factory. In the case of either event, we are not responsible for any transportation costs associated with the warranted claim.

WARRANTY REGISTRATION

Warranty registration must be on file and/or proof of original purchase (detailed and dated receipt) required for warranty to be effective.

<https://realtruck.com/undercover-warranty>

**REGISTER
YOUR
WARRANTY
ONLINE**



Serial Number _____

Date of Purchase _____