



## INSTALLATION INSTRUCTIONS

### VEHICLE APPLICATION

Year: 1999\*-2003 / 2000-03

Make: FORD

Model: F-250, F-350 / EXCURSION

Engine: 7.3L DIESEL

\* Build date of 04/98 and up

### TOOLS REQUIRED

- 13mm Wrench & Socket
- 5/16", 15/32", & 1/2" Wrench & Socket
- 3/16" & #5 Metric Hex Key
- 5/16" Nut Driver or Flat Blade Screwdriver
- Drill and 3/4" Drill Bit (Optional)

### S&B Filter Maintenance

Cleanable (KF-1059). If the enclosed filter is Red, it came pre-oiled from the factory. Please visit [www.sbfilters.com](http://www.sbfilters.com) for exact oil amount required after cleaning.

Disposable (KF-1059D). If the enclosed filter is White, it is a disposable filter and should be discarded once it reaches capacity. This filter (does not require oil). For more info on S&B's disposable filter, visit [www.sbfilters.com](http://www.sbfilters.com).

### NOTES

Kit may not fit with the following:

- Aftermarket Parts installed
- Body Lift or Lowering Kit
- Custom Hood
- Intercooler or Turbo upgrades
- Larger Battery Group #

### CARB Status - Exempt

CARB EO #: D-590-9

Legal for use in CA or other states adopting CA emissions standards. See Page 4 for more info.

### BEFORE YOU START

- Please read the entire product guide before proceeding.
- Ensure all components listed on page 4 are present.
- If you are missing any of the components, call our customer support at (909) 947-0015.
- Do not attempt to work on your vehicle while engine is hot.
- Make sure the engine is turned off and the vehicle is in Park or the Parking Brake is set.

1. With the ignition switched off and the parking brake set, disconnect the negative battery cables on both batteries, then disconnect the positive battery cable on the driver's side only.



2. Remove the OE battery cover by pressing in both tabs on the front of the battery.



3. Remove the battery bolt and wedge then remove the battery from the vehicle.



4. IF EQUIPPED: Disconnect the OE electronic restriction gauge electrical connector. Then, read Step #16 and plan accordingly.

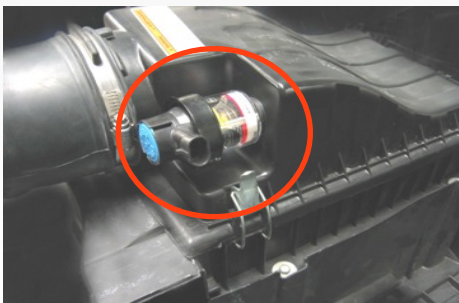

5. Loosen the OE hose clamp at the turbo inlet.



6. Unclamp and remove the OE air box lid and intake tube assembly from vehicle.



7. Remove the four bolts from the OE battery tray bottom and side. NOTE: Early 99' models have a separate steel tray with a additional bolt. Remove this bolt as well, then remove the tray from the vehicle.



8. From the inside of the OE air box, turn the air temp. sensor a 1/4 turn to release it from the air box. CAUTION: Be careful not to damage the sensor.



9. Lift the box and tray assembly up and out of the vehicle. NOTE: Early 99' model OE air boxes have 2 bolts at the inner fender that need to be removed prior to the removal of the air box.



SEE EXPLODED VIEW ON PAGE 5





**INSTALLATION INSTRUCTIONS (continued)**

10. Install the clip nuts (P) onto the Snorkel (Q) then slide the snorkel into the air box.



11. Secure the snorkel (Q) to the air-box (L) using the 2 Hex Head Screws (I) and washers (J).



12. Use the 4 hex head screws (T) washers (N) and nuts (M) to secure the battery tray (R) to the snorkel (Q) and air-box (L).



13. Install the provided grommet (K) into the back of the air box (L).



14. Install the fender seal (O) onto the air box (L).

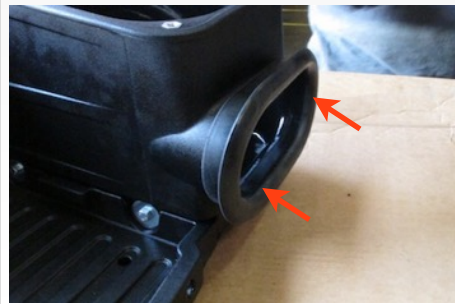

15. Install the tube seal (H) into the air box (L).

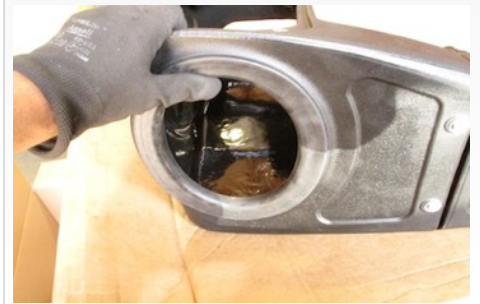

16. **IF EQUIPPED:** To reinstall the electronic air restriction gauge drill a 3/4" hole in the Intake Air Tube (F) at the drill point and insert the OE grommet into the hole. Then, read **Step #32** to complete install.

**NOTE:** OE Restriction Gauges are not calibrated for the S&B Intake Kit, both types (Manual and Electronic) will no longer be accurate. However, the electronic type must be reconnected or the indicator light may be triggered.

**Important:** Service air filter according to S&B precision cleaning instructions. Do not rely on the restriction gauge or wait until the dash light is triggered.



17. Install the intake tube (F) through the tube seal from inside the box, pull out till it touches the first stop bead.



18. Install both hose (A) clamps onto coupler (B) but leave on loose.



19. Slide the coupler with both hose clamps onto and over the intake tube. Push the coupler past both stop beads leaving the end of the tube exposed.



**SEE EXPLODED VIEW ON PAGE 5**





**INSTALLATION INSTRUCTIONS (continued)**

20. Install the battery hardware to the battery tray, do not install the battery wedge yet.

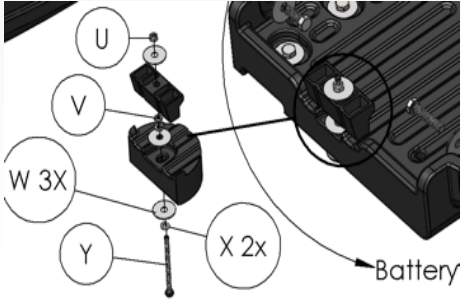

21. Install the complete air box assembly into the vehicle.



22. Install the provided bolts (S) and washers (N) through the battery tray which should thread through to the factory clip nuts on the bottom.



23. Install the provided bolts (S) and washers (N) on the side of the battery tray that connects to the side of the fender.



24. Slide the intake tube forward to make the tube lines up straight with the turbo inlet. Once the tube is aligned with the turbo inlet slide the coupler onto the turbo inlet.

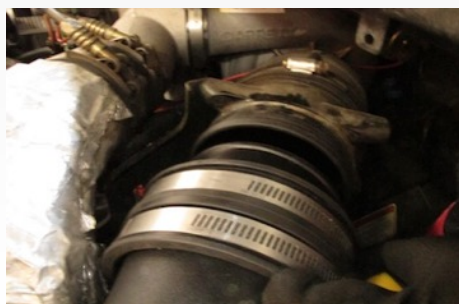

25. Make sure the coupler is properly aligned with the stop beads on the intake tube and turbo inlet. Once properly aligned tighten down both hose clamps.



26. Install the air filter (Z) and tighten the hose clamp. Make sure the filter flange is properly aligned with the stop bead before tightening completely. The filter and tube may need to be adjusted to fit straight with box.



27. Install the battery onto the battery tray.

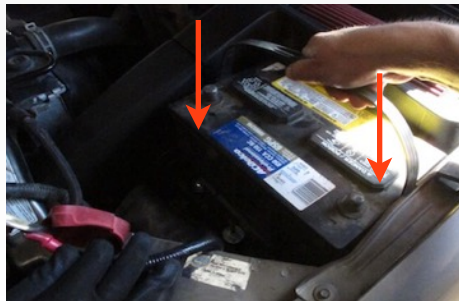

28. Install the OE battery wedge over the M6 screw (Y), then secure the wedge using washer (W) and nut (U).



29. Remove the protective covering from the Clear Lid (E) and install the edge trim (G) by stretching it over the edges.



30. Install the lid onto the air box using the provided screws (C) and rubber washers (D).



31. Install the air temp. sensor on the back of the air box by pushing firmly into the grommet.



**SEE EXPLODED VIEW ON PAGE 5**



## INSTALLATION INSTRUCTIONS

**32. IF EQUIPPED:** reconnect the electronic restriction gauge and push it into the grommet on the intake tube. Press firmly to ensure a air tight seal.



**33.** Reconnect all battery cables, positive cables first. Inspect your installation, make sure the kit is properly positioned and all fasteners are secure. The installation is now complete.



S&B Kit 75-5062 1999-2003  
Powerstroke 7.3L Diesel



### RELATED ITEMS FOR YOUR PURCHASE

- Replacement Air Filter (Oiled)  
(S&B P/N: KF-1059)
- Replacement Air Filter (Dry)  
(S&B P/N: KF-1059D)
- Air Filter Wrap (S&B P/N: WF-1040)

### Precision II Filter Cleaning & Oiling



Order online today at [www.sbfilters.com](http://www.sbfilters.com) or  
through your local S&B distributor.  
Part #: 88-0008

### PERFORMANCE TESTING

- Engage parking brake and start your engine. Listen for abnormal noises. If an air leak is detected, re-inspect hoses and connections as they may need to be repositioned and tightened.
- S&B FILTERS recommends that you keep your OE intake system in the event it is required in the future.
- In order to maintain your warranty, all connections and components must be checked periodically for alignment and for proper tension on all connections. Failure to do so may void your warranty.
- Use only S&B FILTERS cleaning and oil products to service your filter. Using any other brand oil and or cleaners on your S&B air filter may void your warranty. Visit [www.sbfilters.com](http://www.sbfilters.com) for complete warranty information.

## Installation Notes:

---



---



---



---

### Warning!

If your vehicle has a Vehicle Emission Control Information decal affixed to the factory airbox, a new replacement label must be obtained and installed in a readily visible position in the engine compartment in order to remain CARB compliant. Failure to do so will prevent the vehicle from passing a smog check. Replacement labels can be ordered from your local dealership. Regulations state that the VECI label shall not be affixed to any equipment which is easily detached from the vehicle. Label placement, under the hood on a painted surface is recommended.



### Emissions Standard

The California Air Resource Board (CARB) requires that an E.O. identification label be applied to the vehicle in order to pass a smog check inspection when a Performance Intake Kit has been installed. You must place the E.O. label provided on or near the intake kit after installation so that a smog check technician can easily verify the E.O. number. As of April 2009, S&B has never had a product where CARB denied an exemption request; however, the exemption process with CARB can take as long as 18 months. Check the status of the exemption process by looking up a specific part number at [www.sbfilters.com](http://www.sbfilters.com). The CARB Exemption number and/or status is listed under the Product Details section for each part number. If the status shows as "Pending," CARB has yet to issue an exemption but the product has been submitted. Products that have not been issued an EO number are street legal in most states, but may not be used on emission controlled vehicles in the state of California and are for off road use only. If you purchased your kit from S&B Filters directly, we will automatically mail you your Exemption Sticker when it is issued to us. If you purchased your kit from an authorized S&B Filters Dealer, log onto our web site and register to receive your Exemption Sticker.

**SEE EXPLODED VIEW ON PAGE 5**





**EXPLODED VIEW**

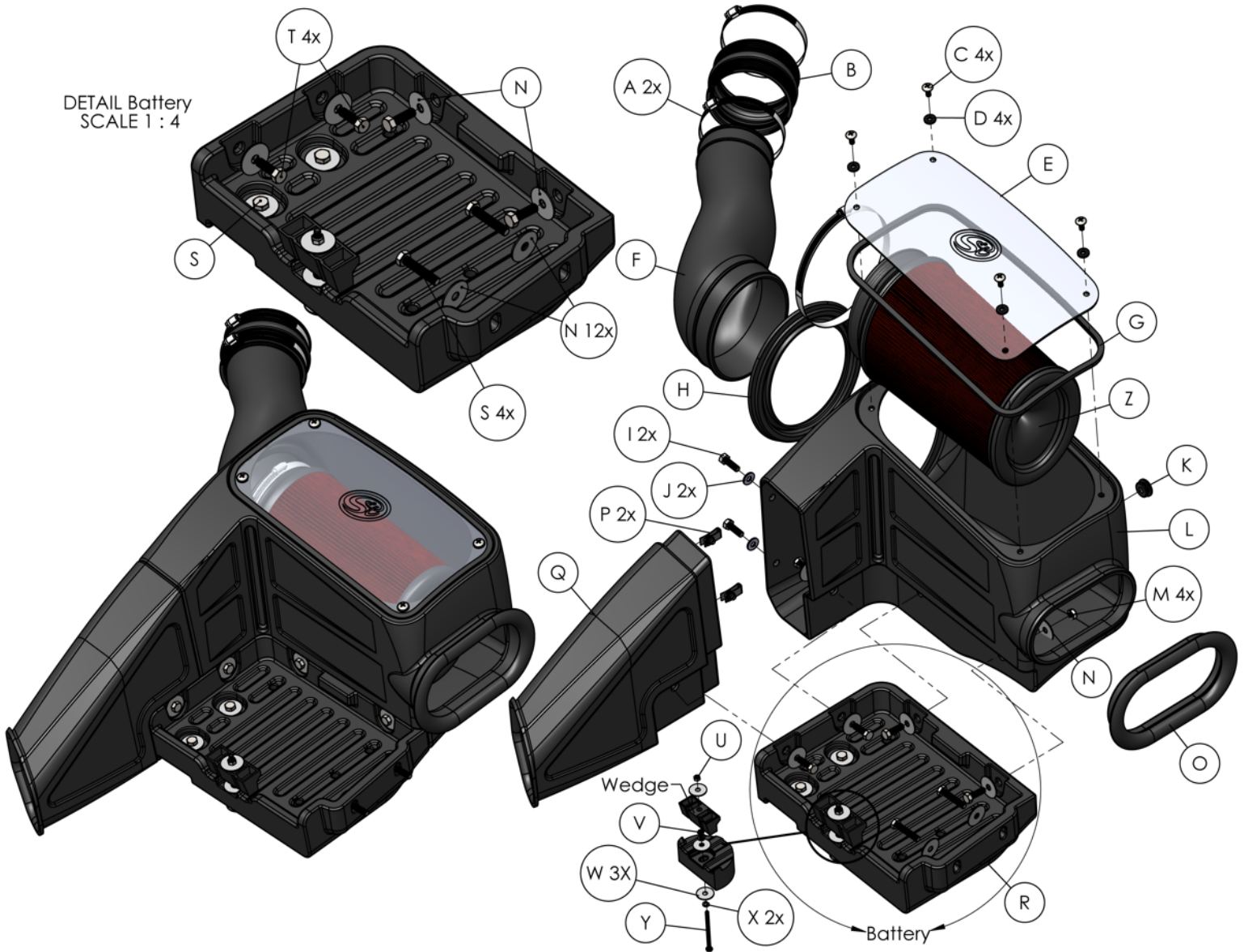

ITEM	QTY.	DESCRIPTION	P/N
A	2	Hose Clamp, #64	AG1018-00
B	1	Straight Coupler	AI1333C-00
C	4	Truss Head Screw	AI1569-00
D	4	Sealing Washer	AI1571-00
E	1	Clear Lid	AI1655-00
F	1	Intake Filter Adapter	AL1198-00
G	1	Edge Trim	AI1636-02
H	1	Tube Seal	AI1657C-00
I	2	Hex Head Screw 1/4-20 x 1"	AI1131-00
J	2	Washer 1/4"	AI1073-00
K	1	Grommet	AI1330-00
L	1	Air Box	AL1198B-00
M	4	5/16-18 SS Nylon Hex Nut	AI1683-00
N	12	Washers 11/32"	AI1080-00

ITEM	QTY.	DESCRIPTION	P/N
O	1	Fender Seal	AI1586C-00
P	2	Clip Nut 1/4-20	AI1059-00
Q	1	Snorkel	AL1198S-00
R	1	Battery Tray	AL1198T-00
S	4	Hex Head M8 x 40mm	AI1163-00
T	4	5/16-18 x 7/8" Hex Bolt	AI1410-00
U	1	Hex Lock Nut	AI1090-00
V	1	Hex Nut	AI1687-00
W	3	Washer 1/4 x 1-1/4"	AI1075-00
X	2	Split Lock Washer	AI1685-00
Y	1	Hex Head Screw M6 90mm	AI1413-00
Z	1	Filter	KF-1059

AM0212-00 Rev.C 10/05/2015

**Warranty**

Visit [www.sbfilters.com](http://www.sbfilters.com) for complete warranty information.