



OMIX-ADA, Inc.

Part # 11585.04

460 HORIZON DR. SUITE 400 | SUWANEE, GA 30024 | PHONE: 770-614-6101 | FAX: 770-614-6069 | info@omix-ada.com

Accessory Brake Light LED Ring PATENT PENDING

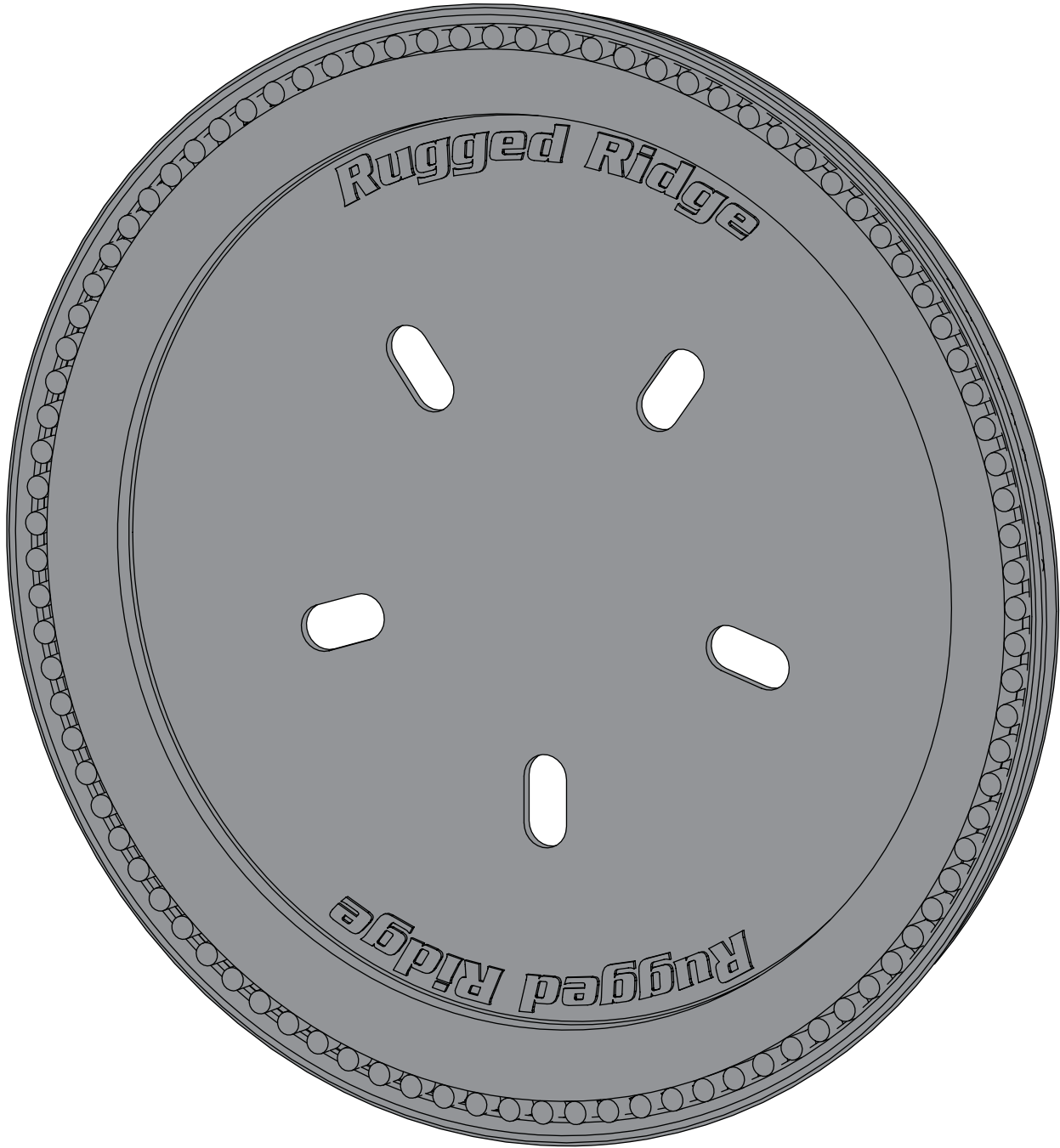

OMIX-ADA® TECHNICAL SUPPORT

PHONE: M-F 8am - 5pm EST 1-800-449-6649 | **EMAIL:** techsupport@omix-ada.com

FOR WARRANTY INFORMATION VISIT: www.Omix-Ada.com



OMIX-ADA, Inc.

460 HORIZON DR. SUITE 400 | SUWANEE, GA 30024 | PHONE: 770-614-6101 | FAX: 770-614-6069 | info@omix-ada.com

Accessory Brake Light LED Ring PATENT PENDING

1. Remove spare tire.



Have another person help lift tire off tire mount.

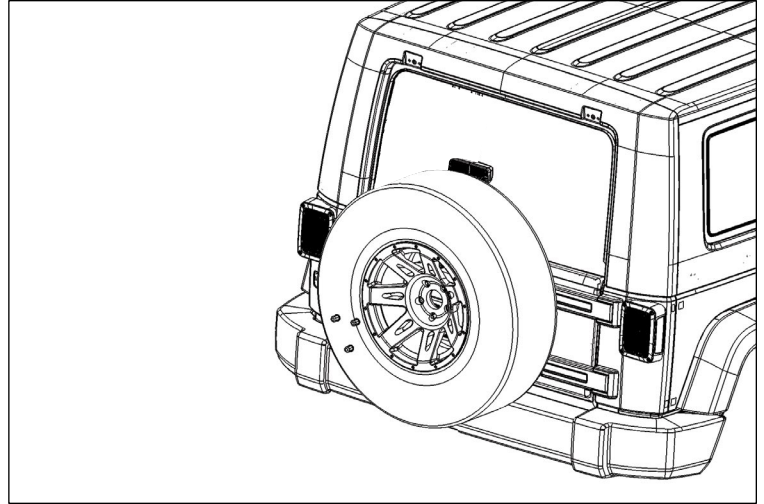

2. Attach Accessory Brake Light to spare tire mount by sliding over wheel studs.



Proceed to Step 3 if installing on 2007 to 2017 Wrangler.

Skip to Step 7 if installing on earlier model.

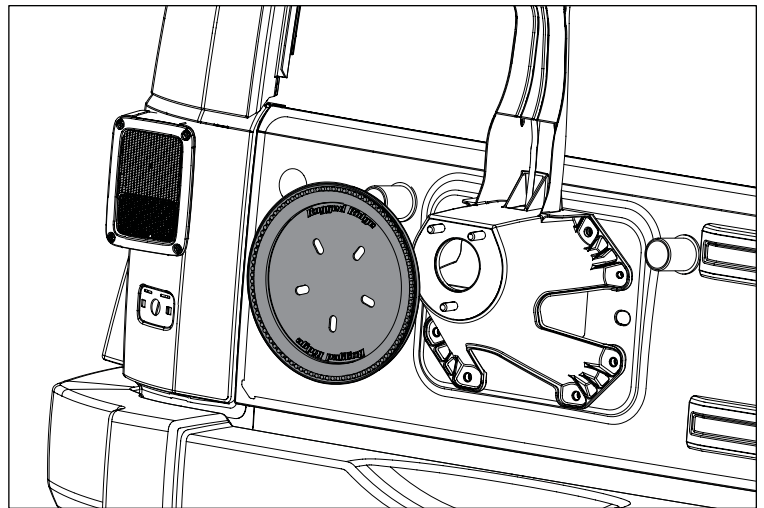

3. Open tailgate. Using T-20 Torx bit, remove four screws attaching third brake light to factory tire mount.

4. Pull third brake light away from tire mount. Remove electrical connector by depressing tab. Set third brake light aside to be used again.

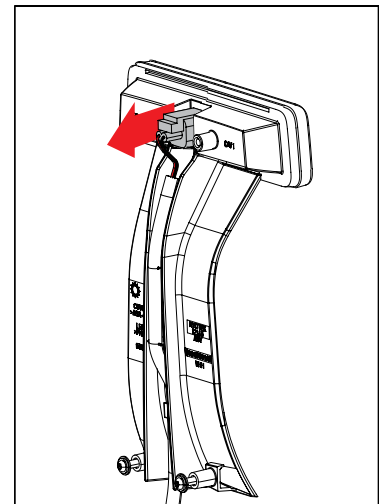
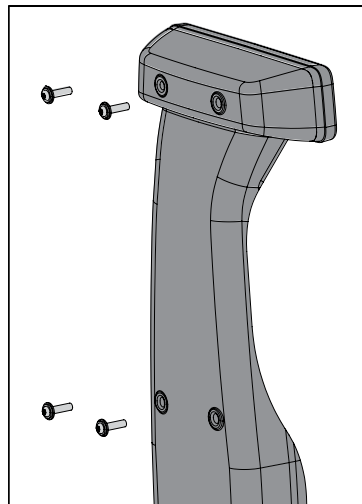



OMIX-ADA, Inc.

460 HORIZON DR. SUITE 400 | SUWANEE, GA 30024 | PHONE: 770-614-6101 | FAX: 770-614-6069 | info@omix-ada.com

Accessory Brake Light LED Ring PATENT PENDING

5. Connect Accessory Brake Light plug to factory third brake light harness.

WARNING

LED Ring is not a DOT approved third brake light. Check with state and federal ordinances regarding third brake light use.

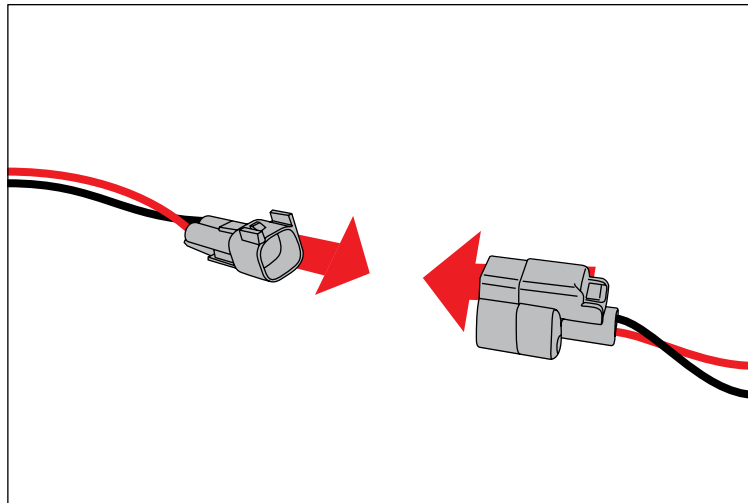

6. Reattach factory third brake light to tire mount.

NOTICE

Skip to Step 10 if installing on 2007 to 2017 Wrangler.

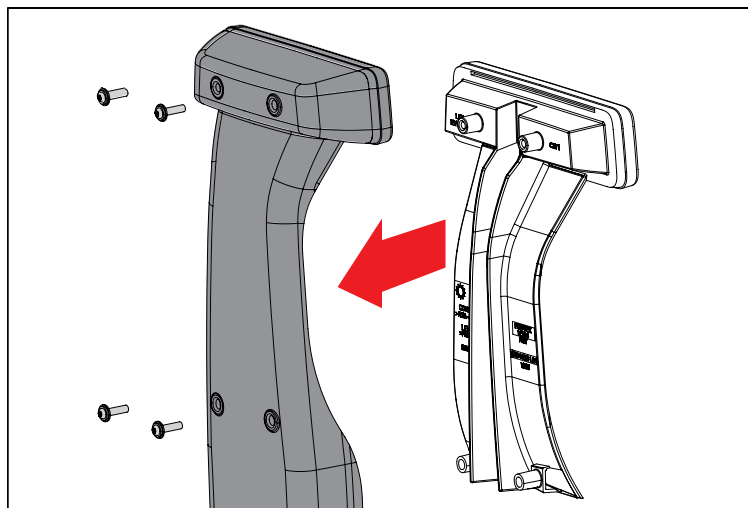

7. Disconnect battery by removing negative terminal first, then positive. Unsheath factory third brake light wires. Cut and strip both ends.

WARNING

When removing battery cables do not touch positive and negative terminals together.

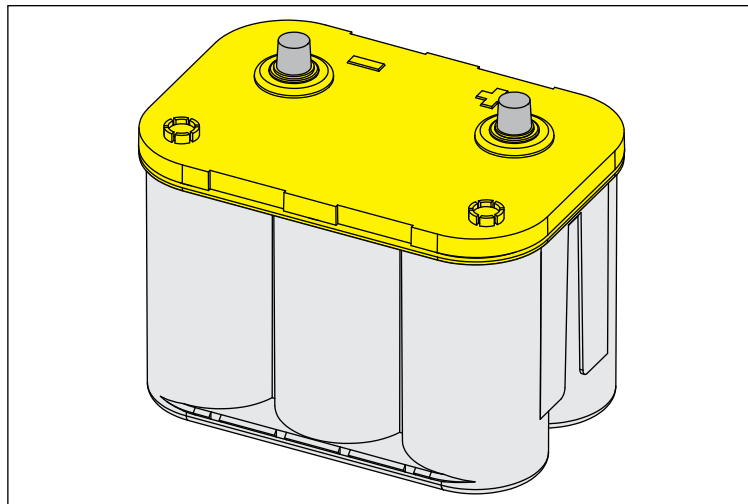



OMIX-ADA, Inc.

460 HORIZON DR. SUITE 400 | SUWANEE, GA 30024 | PHONE: 770-614-6101 | FAX: 770-614-6069 | info@omix-ada.com

Accessory Brake Light LED Ring PATENT PENDING

8. Cut Accessory Brake Light plug three inches from end and strip wires on Accessory Brake Light.

9. Using supplied butt connectors, splice factory third brake light and Accessory Brake Light in one end and factory wiring in other end. Reconnect battery.

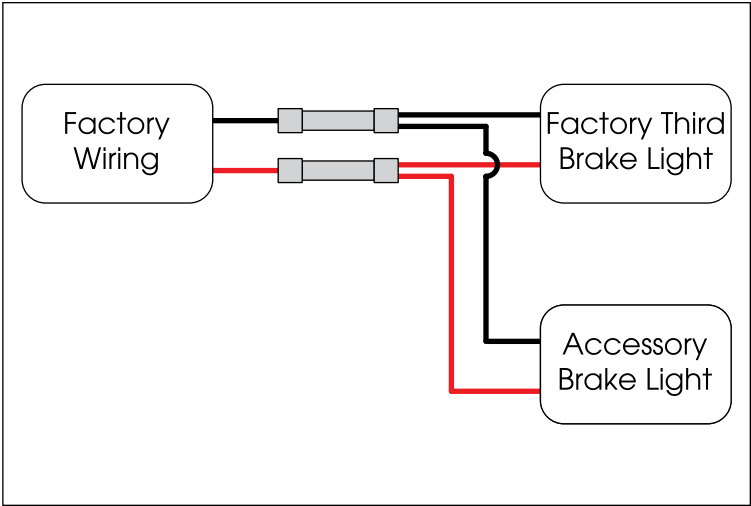

10. Install spare tire and torque lug nuts to factory specification. Depress brake pedal and check for brake light functionality.



Have another person help lift tire on tire mount.



Failure to tighten lug nuts to proper torque specification could result in serious injury or property damage.

