



OMIX-ADA, Inc.

460 HORIZON DR. SUITE 100 | SUWANEE, GA 30024 | PHONE: 770-614-6101 | FAX: 770-614-6069 | info@omix-ada.com

Part #11594.02

'11-15 Jeep Grand Cherokee Viewpoint Aluminum Running Board

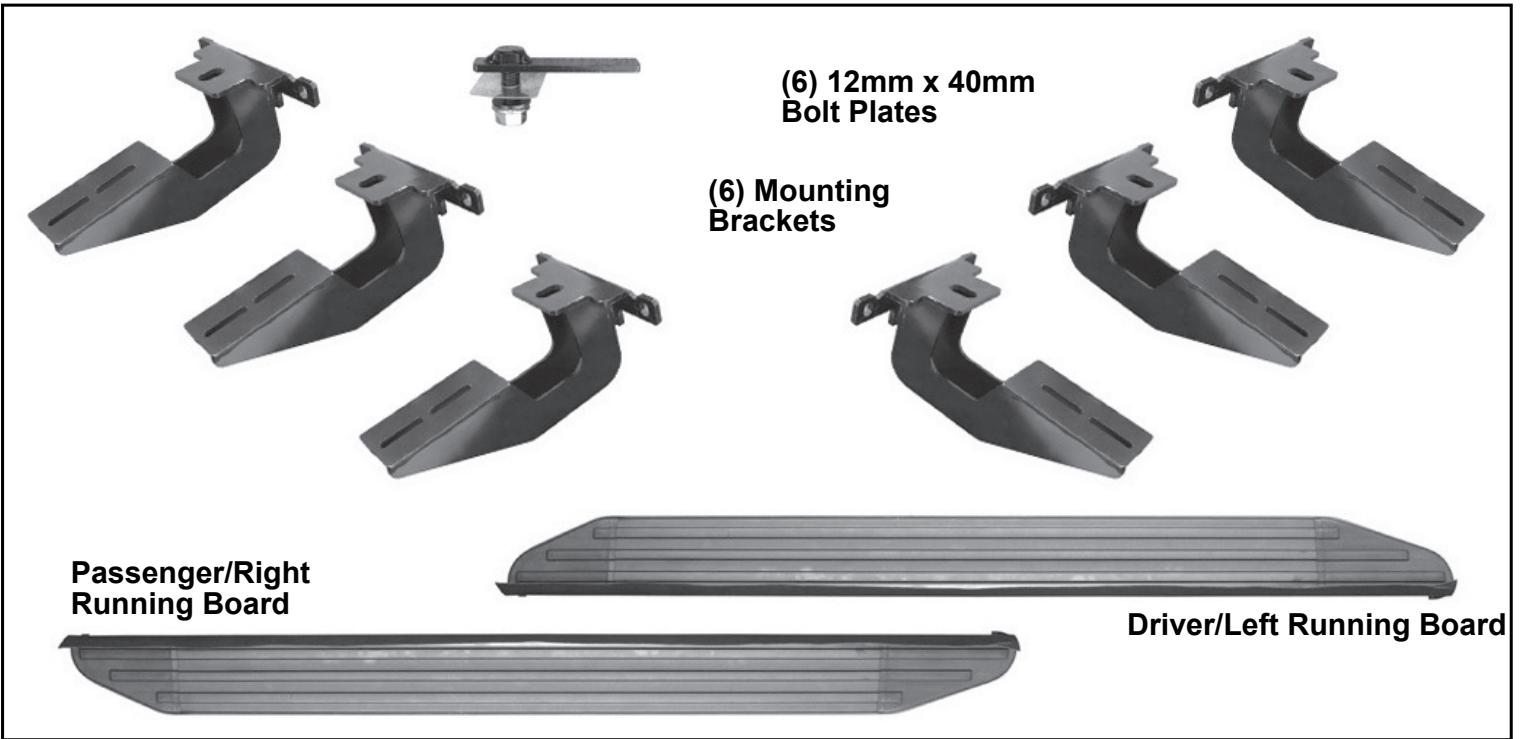

Components

- | | | | |
|-------------------------------------|-----|---|------|
| 1. Driver/Left Running Board | (1) | 8. 6mm "T" Bolts | (12) |
| 2. Passenger/Right Running Board | (1) | 9. 6-1mm x 25mm Hex Bolts | (12) |
| 3. Mounting Brackets | (6) | 10. 6mm x 22mm x 2mm Large Flat Washers | (24) |
| 4. 12-1.75mm x 40mm Bolt Plates | (6) | 11. 6mm x 18mm x 1.6 Std. Flat Washers | (12) |
| 5. 12mm Serrated Flange Nuts | (6) | 12. 6mm Lock Washers | (12) |
| 6. 12mm x 25mm x 2.5mm Flat Washers | (6) | 13. 6mm Hex Nuts | (12) |
| 7. 12mm Plastic Retainers | (6) | 14. 6mm Lock Nuts | (12) |

OMIX-ADA® TECHNICAL SUPPORT

PHONE: M-F 8am - 5pm EST 1-800-449-6649 | EMAIL: techsupport@omix-ada.com

FOR WARRANTY INFORMATION VISIT: www.Omix-Ada.com



OMIX-ADA, Inc.

460 HORIZON DR. SUITE 100 | SUWANEE, GA 30024 | PHONE: 770-614-6101 | FAX: 770-614-6069 | info@omix-ada.com

'11-15 Jeep Grand Cherokee Viewpoint Aluminum Running Board

Remove contents from box. Verify all parts are present. Read instructions carefully before starting installation. Assistance is highly recommended. Excludes SRT8 and Trailhawk.

1. If wiring harness attached behind the pinch weld is present, remove hex nuts and drop harness down.



2. Remove rubber plug filling oval hole in bottom of rocker panel in front of two front holes in pinch weld.



3. Partially thread 12mm Plastic Retainer onto 12mm Bolt Plate.

4. Insert Bolt Plate into hole and rotate 90-degrees to go across slot. Thread Plastic Retainer rest of way down Bolt Plate and tight against body panel.

NOTICE Plastic Retainer is designed to prevent Bolt Plate from falling into body cavity and aid in installing Bracket.





OMIX-ADA, Inc.

460 HORIZON DR. SUITE 100 | SUWANEE, GA 30024 | PHONE: 770-614-6101 | FAX: 770-614-6069 | info@omix-ada.com

'11-15 Jeep Grand Cherokee Viewpoint Aluminum Running Board

5. Secure Mounting Bracket to Bolt Plate with 12mm x 24mm Flat Washer and 12mm Serrated Flange Nut. Do not fully tighten.

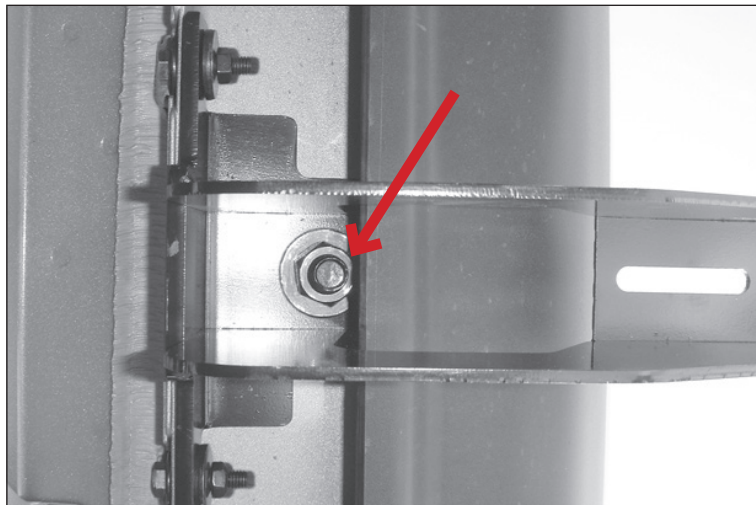

6. Align small slots in Mounting Bracket with holes in pinch weld. Attach using 6mm x 25mm Hex Bolt and 6mm x 18mm Std. Flat Washer through back of pinch weld and Bracket.

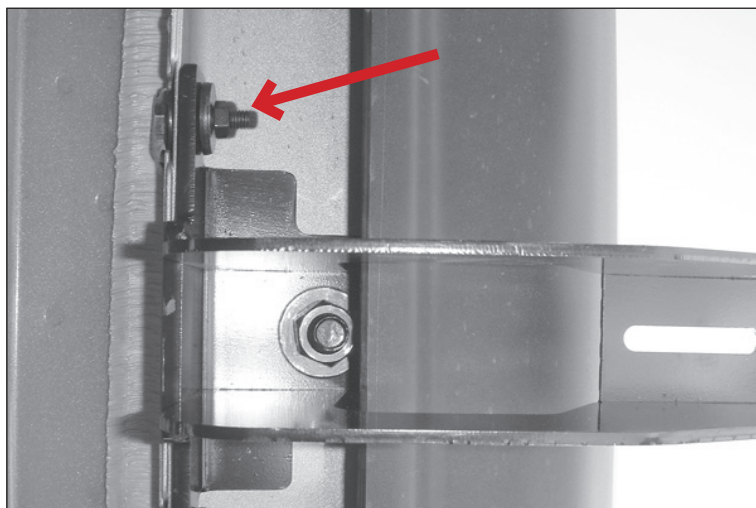

7. Secure using 6mm x 22mm Large Flat Washer and 6mm Nylon Lock Nut. Do not fully tighten. Repeat for remaining mounting hole in Bracket and pinch weld.

8. Repeat steps 1-7 for Center and Rear Brackets.

9. Insert 6mm T-Bolts into each channel through openings in bottom of Running Board. Align T-Bolts with holes in Brackets.

10. Carefully place Running Board onto Brackets. Slide T-Bolts to drop into slots on Brackets.

NOTICE It may be necessary to lower Brackets to insert Running Board. Loosen hardware as necessary.





OMIX-ADA, Inc.

460 HORIZON DR. SUITE 100 | SUWANEE, GA 30024 | PHONE: 770-614-6101 | FAX: 770-614-6069 | info@omix-ada.com

'11-15 Jeep Grand Cherokee Viewpoint Aluminum Running Board

11. Secure Running Board to Brackets with 6mm x 22mm Large Flat Washers, 6mm Lock Washers, and 6mm Hex Nuts, (Figure 11). Do not fully tighten.

12. Adjust and level Running Board and fully tighten all hardware.

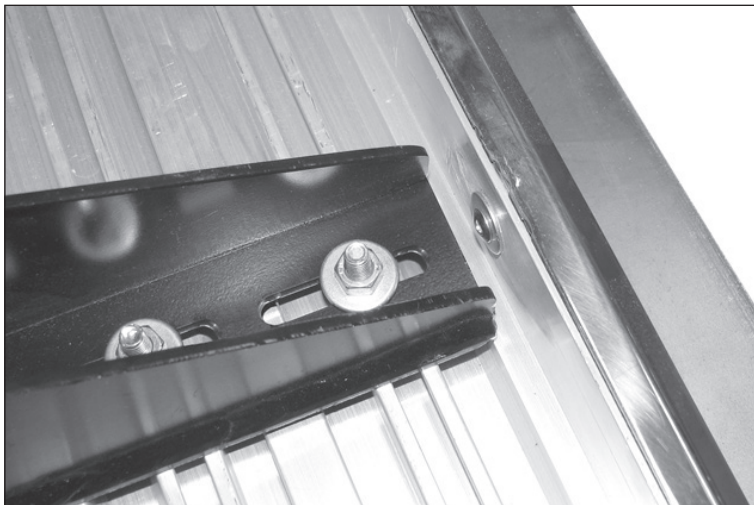

13. Repeat Steps 2-12 for second Running Board.

14. Do periodic inspections to installation to ensure all hardware is secure and tight.



To protect your investment, wax this product after installing. Regular waxing is recommended to add a protective layer over the finish. Do not use any type of polish or wax that may contain abrasives that could damage the finish.

For stainless steel: Aluminum polish may be used to polish small scratches and scuffs on the finish. Mild soap may be used also to clean the Running Boards.

For gloss black finishes: Mild soap may be used to clean Running Boards.