



Installation Guide



1999 - Current Toyota Tundra

PRODUCT CODES:
"546", "556" & "565"



ROLL-N-LOCK CORPORATION
915 South Dixie Highway E • Pompano Beach, FL 33060
Ph. (954) 785-7655 • www.rollnlock.com

Installation Guide

Tools Needed:

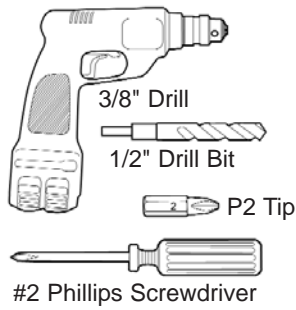

Components Included:

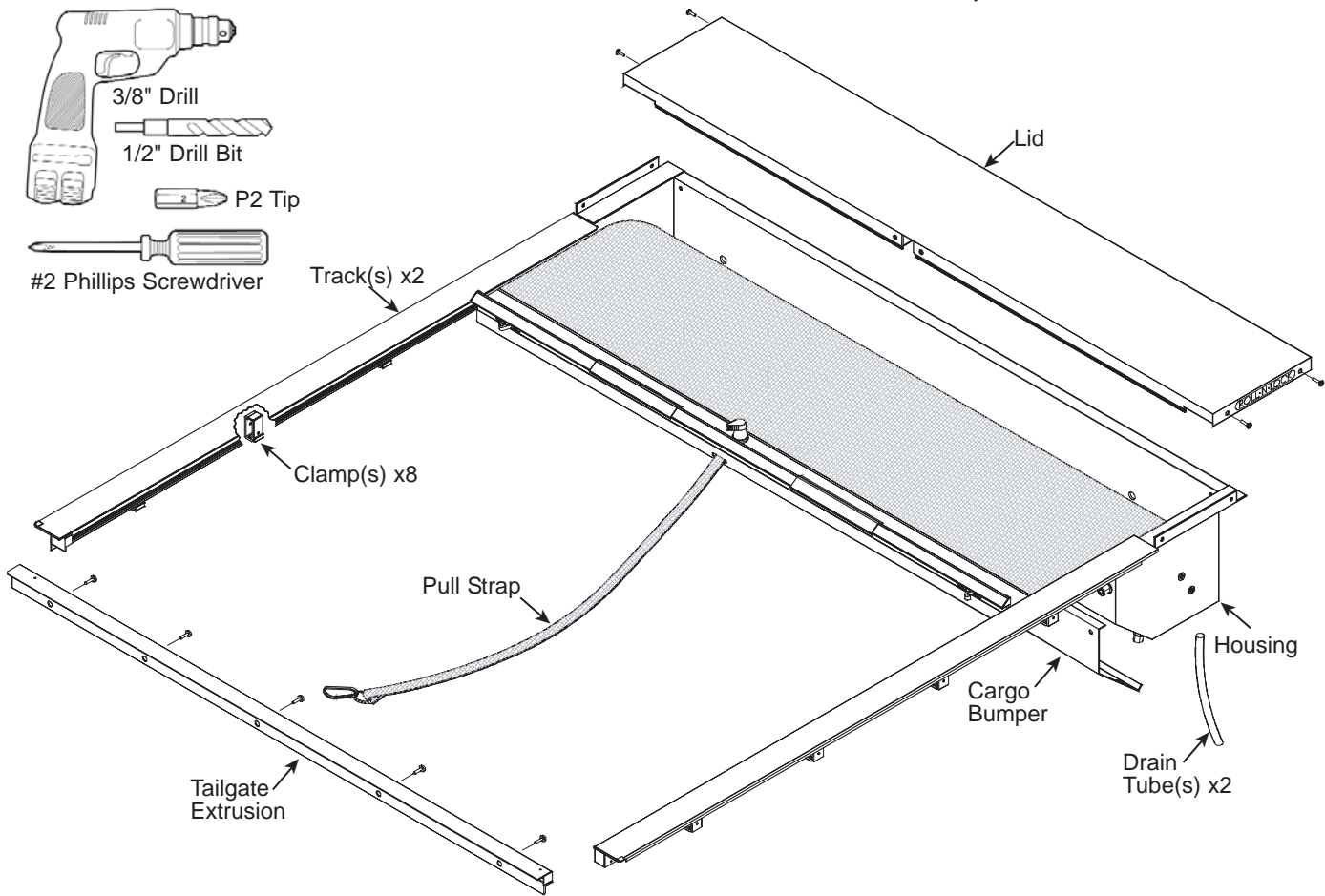

STOP!

If you have a plastic drop-in bedliner, be sure to follow Step 1 on the next page.

If no bedliner is present, proceed to Step 2.



Step 1: Bedliner Modification

Note: If the truck is equipped with a plastic drop-in bedliner, some alteration will be necessary.

If no bedliner is present, proceed to Step 2.

A. The dotted lines in **Diagram 1** depict the more common **under-the-rail** liner modifications.

1. Using a jig saw with a medium tooth blade, remove the bulkhead portion of the liner as indicated.
2. Be sure to trim the bedliner's plastic tailgate panel as shown.

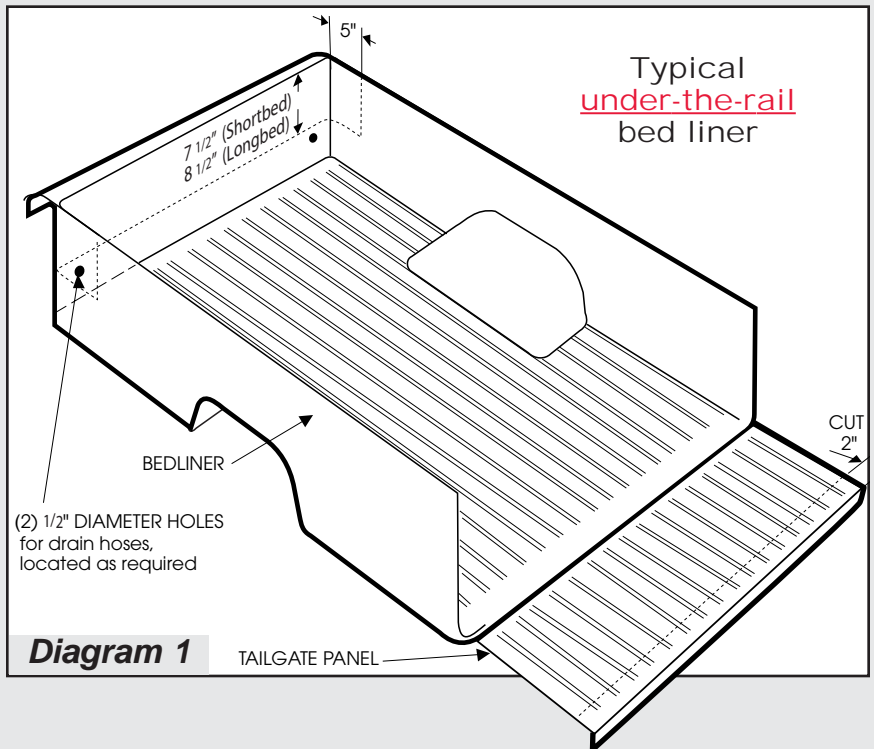

B. The dotted lines in **Diagram 2** depict the less common **over-the-rail** liner modifications.

1. Using a jig saw with a medium tooth blade, remove the top cap and bulkhead portions of the liner as indicated.
2. If a rear notch is necessary, place the tracks on their respective bedrails and mark the positions of the most rearward clamps prior to removing the liner. (The correct position of the track is with the black plastic track end-cap touching the inside surface of the tailgate.)
3. When the modification is complete, push the wall of the liner under the bedrail.
4. Be sure to trim the bedliner's plastic tailgate panel as shown.

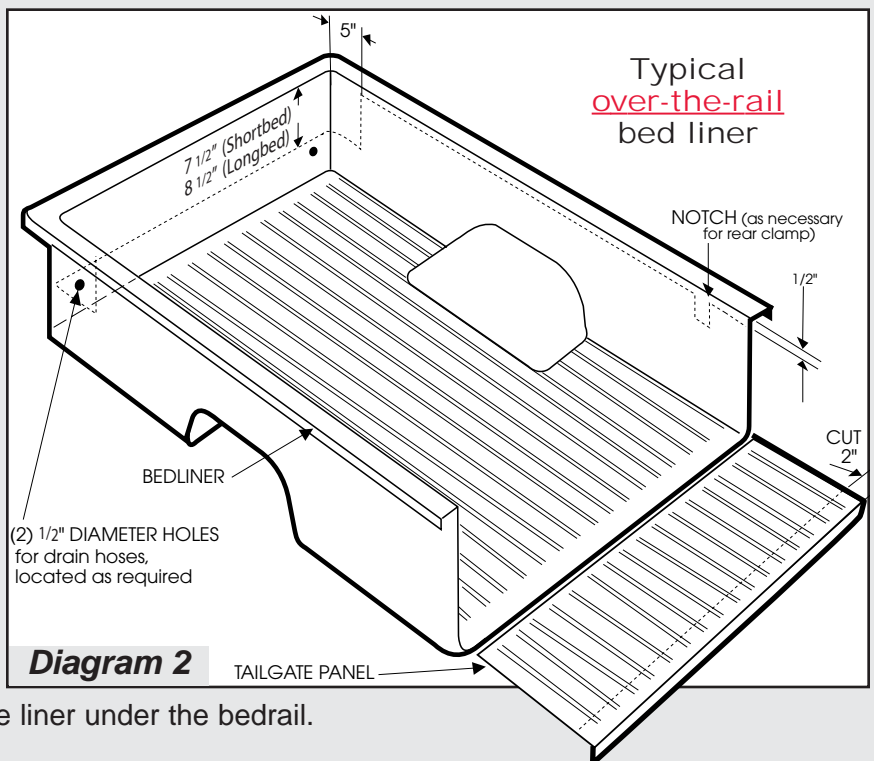

STOP!



If your truck is a '99 - Current Tundra regular cab (unit #556), proceed to Step 3.

Step 2: Shim the OE Bedrail Caps (units 546 & 565)

- A. Remove the plastic bedrail caps, starting at the tailgate and lifting slowly (**Photo 3**). Allow each snap to release as you proceed, being careful not to overstress the rail cap.



Photo 3

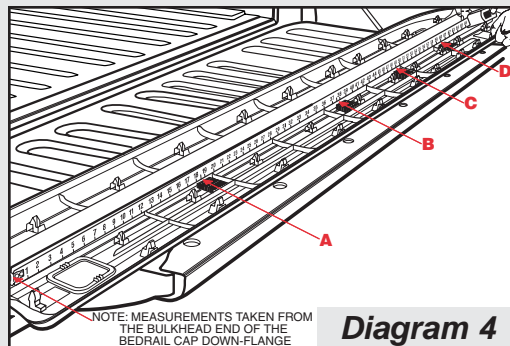

- B. Place the correct stick-on shim pads at the locations shown in **Diagram 4**. **Note:** The measurements shown in the graph below are taken beginning from the bulkhead end of the bedrail cap down-flange. Be sure to center the shims at each location and place them against the down flange as shown in **Diagram 5**.

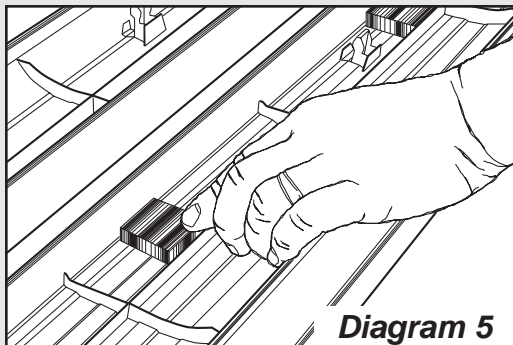

Diagram 5



Photo 6

Product Code	A	B	C	D
546 (all 1/4" shims)	16"	37"	49"	61"
565	1/8" shim @ 18 1/2"	1/4" shim @ 37 1/2"	3/8" shim @ 49"	1/2" shim @ 60"

- C. With the shims in place, snap the rail caps back into place, starting at the bulkhead and working toward the tailgate (**Photo 6**).

Step 3: Install the Housing

- A. Place the housing assembly onto the bedrails (**Photo 7**). Center it between the bedrails and leave about ½" of space between the bulkhead and the back of the housing. **Do not fasten the housing in place.**



- B. Remove the lid from the housing (**Photo 8**) and discard the plastic packing bolts.

Step 4: Install the Tracks

- A. Carefully place the tracks on the bedrails (**Photo 9**) and key them onto the housing stems (**Diagram 10**), being sure that the handle is properly engaged into the tracks .

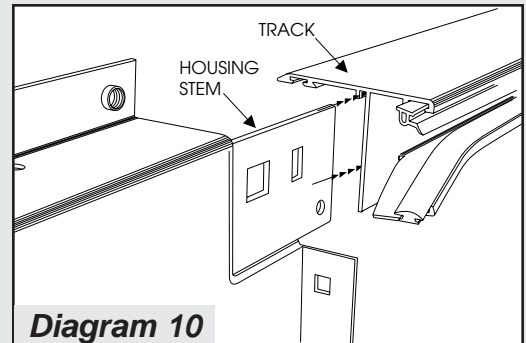
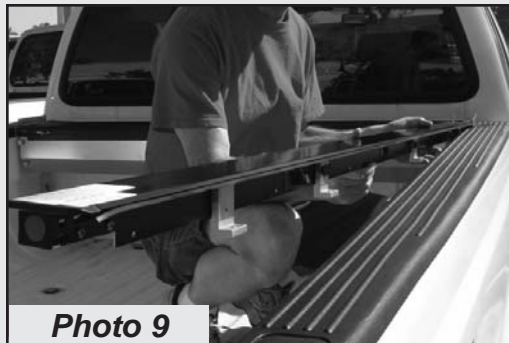

- B. Attach the back clamps very loosely to the tracks to be sure that the tracks do not fall off of the bedrail while proceeding (**Photo 11**).

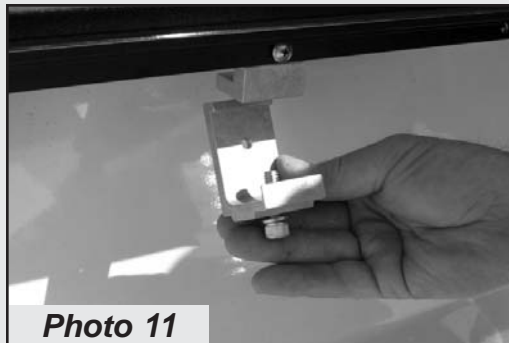

- C. Use #10-24 x ½" truss head screws and cargo nuts to secure the tracks to the housing stems (**Photo 12**).

- D. Attach the remaining clamps very loosely. **Do not tighten yet.**

STOP!



If your truck is a '99 - Current Tundra *regular cab* (unit #556), you must remove the factory tailgate cap and replace it with a 1/16" thick aftermarket tailgate cap.

Step 5: Install the Tailgate Extrusion

- A. Lower the tailgate and, using a tape measure, locate and mark the center of the tailgate (**Photo 13**).
- B. Using a tape measure, locate and mark the center of the tailgate extrusion (**Photo 13**).
- C. While holding it square and centering the tailgate extrusion on the tailgate, use a #8 x 3/4" self tapping screw and power screw gun to secure the center hole (**Photo 14**). Next, move to each end, **press the tailgate extrusion to the top of the tailgate in order to make it conform to the contour of the tailgate, and secure it in place.**
- D. Install the remaining self-tapping screws, making sure to provide even spacing between them.
- E. With the tailgate extrusion secured, carefully close the tailgate, being cautious not to strike the ends of the tracks.



Photo 13



Photo 14

Step 6: Orienting the Tracks to the Tailgate

- A. Move to the front of the bed, lift up slightly on the housing and shift each side back toward the tailgate (**Photo 15**) so that the track end-caps contact the inside surface of the tailgate, and match-up with the tailgate extrusion end-caps (**Photo 16**). **Note that if the tracks are not positioned as shown, the latch mechanism will not function correctly.**



- B. With the tracks in the correct position, you may now tighten the clamps in the order shown (**Diagram 17**), taking care to make sure the tracks remain level.

Do not use a power or pneumatic screw gun. Over tightening track clamps can cause an indentation in the bedrails.

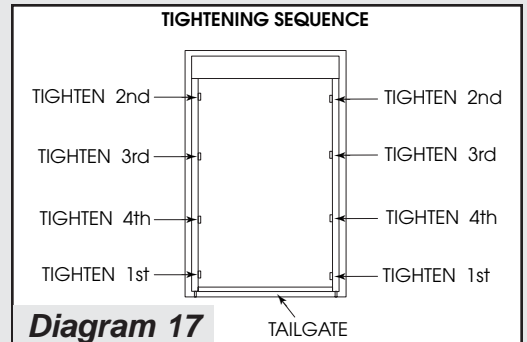
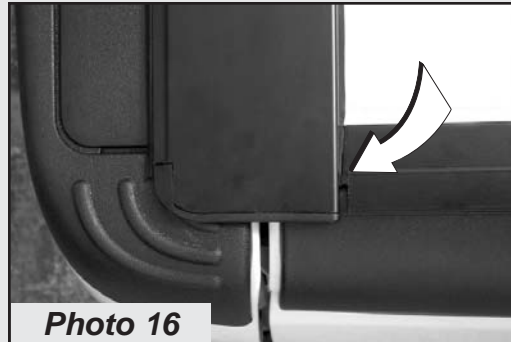

- C. If the track rolls upward, rotate the track level and install the optional Angularity Adjustment Screw as shown (**Diagram 18**). Tighten the Screw until it biases against the bedrail down-flange as shown.

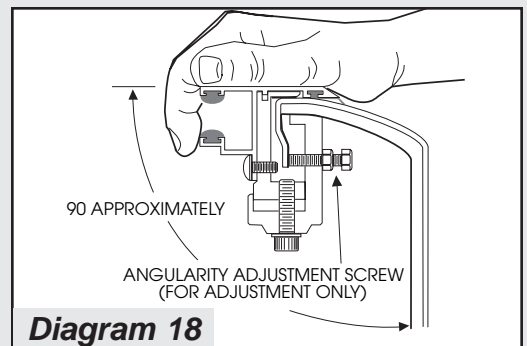

Step 7: Installing the Lid, Cargo Bumper and Drain Tubes

- A. Remove the plastic wing nut and detach the pull strap from the threaded stud (**Photo 19**). Pull the cover closed and latch it to the tailgate.



Do not allow the cover to retract without the lid in place. If included, remove the packing filler from the housing (**Photo 20**).

Step 7: Installing the Lid, Cargo Bumper and Drain Tubes

- B. Place the lid onto the housing flanges (**Photo 21**), and secure it in place with $\frac{1}{4}$ - 20 x $\frac{5}{8}$ " black countersunk screws. **Do not use a power or pneumatic screw gun.**
- C. With the lid secured in place, you may test operate the *ROLL-N-LOCK*[®] cover. The cover should retract on its own with only a slight push from the tailgate end. When pulled closed, it should latch effortlessly.
- D. Use $\frac{1}{4}$ - 20 x $\frac{1}{2}$ " truss head screws and rubber washers to secure the cargo bumper (**Photo 22**). **Note that the rubber washers go on the inside of the cargo bumper (Diagram 23).**



Photo 21



Photo 22

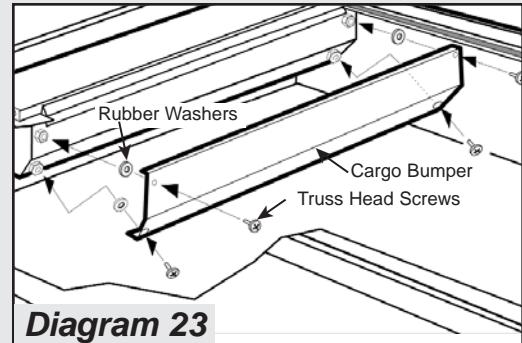

Diagram 23

- E. Use a $\frac{1}{2}$ " bit to drill holes for the drain tubes (**Photo 24**). Note that this process is easier if a $\frac{1}{4}$ " pilot hole is drilled first. Align the holes with the drain tube fittings and locate them about 3"-4" below the housing.
- F. **Make sure the pull-strap is securely clipped to a fixed point in the bed.**



Photo 24

Step 8: Place the Hang Tag on Review Mirror

- A. Eliminate come-backs by giving your customers a friendly reminder of how to use and maintain their new *ROLL-N-LOCK*[®] retractable cover for maximum satisfaction. This hang-tag will get noticed immediately on the rear view mirror of your customer's pickup, providing them with everything they need to know. And, they will also appreciate knowing about our new *CARGO MANAGER*[®]; the perfect accessory for use with *ROLL-N-LOCK*[®] retractable covers.



ROLL-N-LOCK CORPORATION
915 South Dixie Highway E • Pompano Beach, FL 33060
Ph. (954) 785-7655 • www.rollnlock.com