



## 5-Button Keypad Guide

# INSTALLATION SHEET

### Any damaged or missing parts?

Parts will be shipped to you directly.

Call 800-206-4070 Mon - Fri, 8:30 a.m. - 5:00 p.m. CST  
or email [retrax@retrax.com](mailto:retrax@retrax.com)

### PARTS INCLUDED IN YOUR KIT

- A** 1 EQ keypad
- B** 1 Access code card

### TOOLS REQUIRED

- Isopropyl alcohol

### CABIN MODULE

- Mentioned but only included with cover.

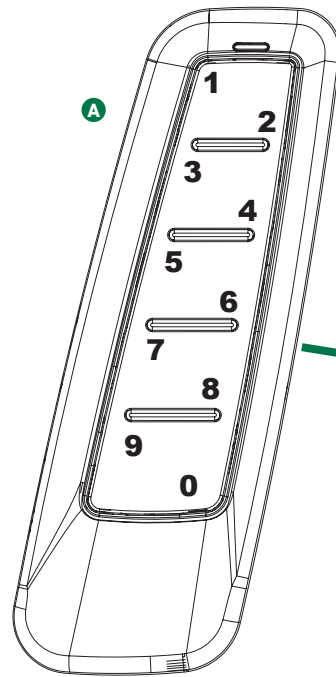
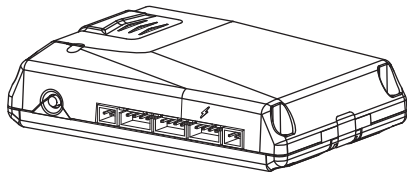

The 5-button keypad is designed to be placed on the outside of the driver's side pillar, rear of cabin.

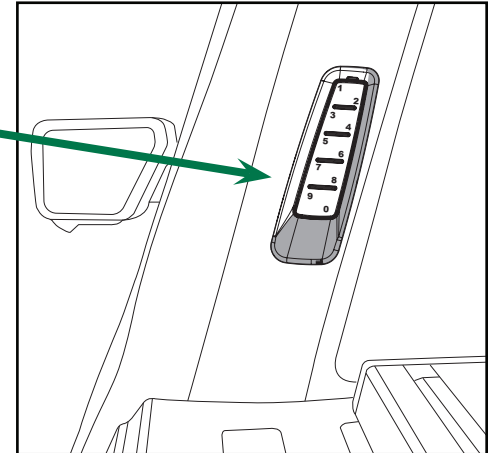

## 1 To program the keypad:

1. Set the cabin module to pairing mode. (Before proceeding you must: 1. Unlock the vehicle using the factory remote. 2. Enter the vehicle. 3. Close all doors. Then follow these steps within one minute: Turn IGN ON. Open and close the door. Press and hold the brake. Open the door. Release the brake.)
2. On the keypad, enter configuration mode by simultaneously pressing buttons 1/2, 3/4, and 9/0 (A) for at least 2 seconds. Backlight LED (B) will flash three times.
3. Enter the master code. The backlight and green LED (B) will flash slowly two times and then turn off.
4. Within 20 seconds, press and hold the 5/6 button (C) until the backlight LED flashes rapidly and the cabin module unlocks the vehicle, confirming pairing has been successful.

**Important!** If pairing fails, wait for the LEDs to turn off. Then, repeat steps 2 and 3, and at step 4 press and hold 7/8 until the LED flashes rapidly. Finally, you can repeat steps 1-4.

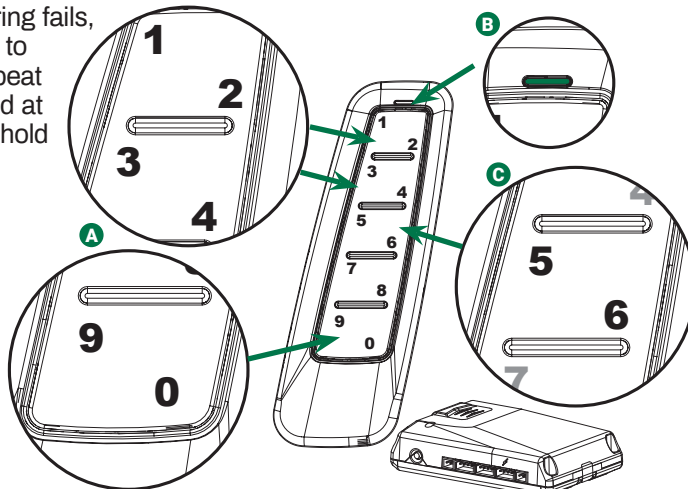

## 2 To mount the keypad:

1. Clean and prep the installation area with an isopropyl alcohol-based solution.
2. Allow the surface to dry completely before placing the keypad on the pillar.
3. Remove the red plastic backing from the adhesive pad on the rear of the keypad. Firmly press for 60 seconds to ensure proper adhesion to the vehicle.

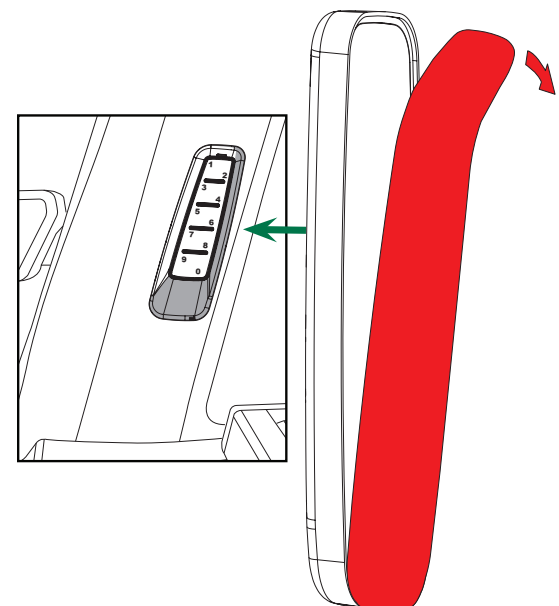

### 3 To program a personal pin code:

The user can assign a 5-digit secondary password.

**Note:** Keypad must be paired to a cabin module before entering the secondary code.

1. Enter configuration mode by pressing and holding buttons 1/2, 3/4 and 9/0 (A), indicated by three blinks of backlight (B).
2. Enter the master code.
3. Press and hold button 3/4 (B) to enter user code mode, indicated by three blinks of green LED (C).
4. User has five seconds to enter new code. **Note:** Each press will give the user five seconds to enter the next key. If successful, backlight will blink three times and the keypad will go to sleep in two seconds. If timeout occurs, backlight will blink once, and the keypad will go to sleep in two seconds.

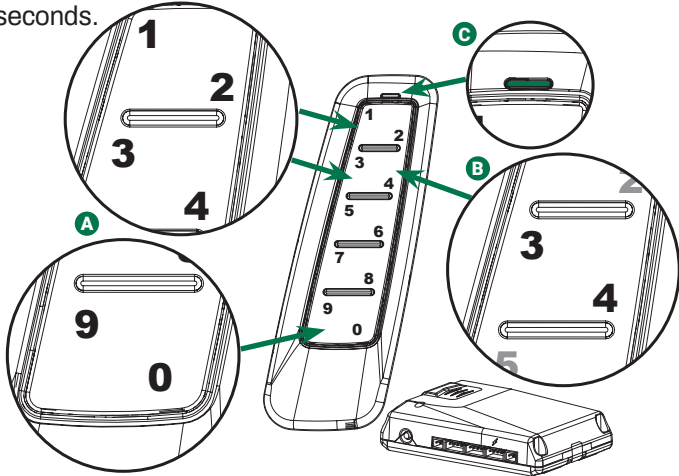

### 4 To delete a personal pin code:

1. Enter Configuration mode by pressing and holding buttons 1/2, 3/4 and 9/0 (A), indicated by three blinks of backlight (B).
2. Enter the master code.
3. Press and hold button 3/4 (C) to enter User Code mode, indicated by three blinks of small LED.
4. Wait five seconds for the code to be deleted. After five seconds, the backlight LED (B) will blink once, and the keypad will go to sleep in two seconds. User code has been cleared.

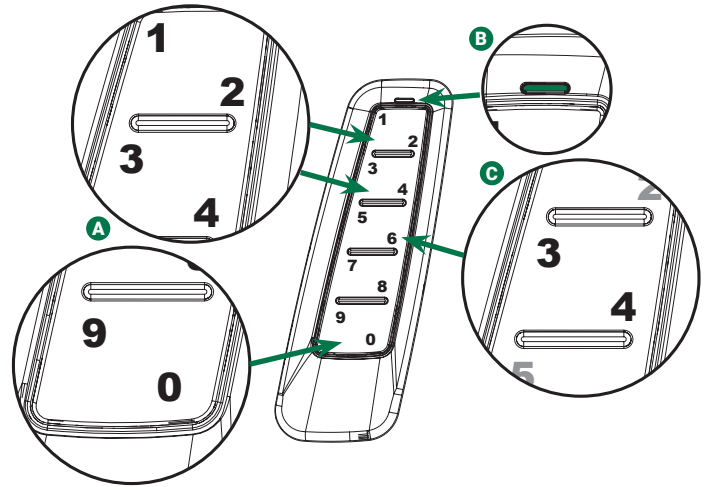

### 5 Anti-Scan mode: The keypad will allow:

- Three attempts to enter the 5-digit code correctly or sixteen button presses.

**Note:** If all three attempts fail to enter the correct 5-digit code (master code or personal code), the keypad will activate "Anti-Scan/Lockout Mode" for one minute, disabling the keypad unlock functions.

- One button press to wake up the keypad from "sleep mode".
- Three attempts to enter the 5-digit code correctly.
- The Lock function (press 7/8 and 9/0 simultaneously) will continue to operate even if the keypad is in Anti-Scan/Lockup mode.
- After one minute, the Anti-Scan Mode will deactivate, and the keypad functions will reset to normal operation.
- If the three attempts fail to enter the correct 5-digit code (master code or personal code) for a second or third time, the keypad will activate "Anti-Scan/Lockout Mode" for one minute. The same conditions will apply.
- If there are any additional three attempts that fail to enter the correct 5-digit code (master code or personal code), the keypad will activate "Anti-Scan/Lockout Mode" for five minutes.

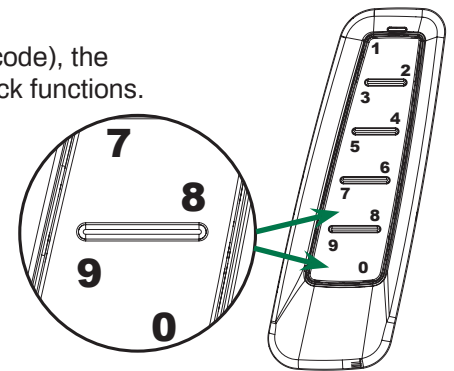

### 6 LED Flash Pattern Indicator:

- The backlight and green LED indicator (A) at the top of the keypad

will quickly flash three times each time a button is pressed while the keypad is in Anti-Scan/Lockout mode.

- The transmit LED indicator at the top of the keypad will slowly flash one time when the Anti-scan/Lockout mode times out.

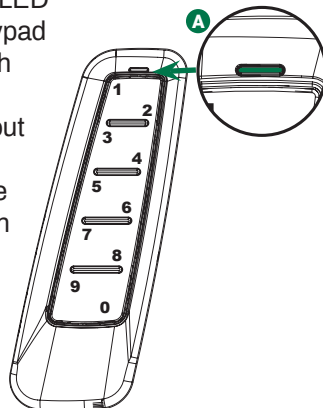

### 7 To unlock the vehicle:

1. Enter the 5-digit code.
2. Quickly press and release the 3/4 button (A).

The parking lights (B) will flash two times, indicating the system is disarmed and has unlocked the doors (if equipped and connected).

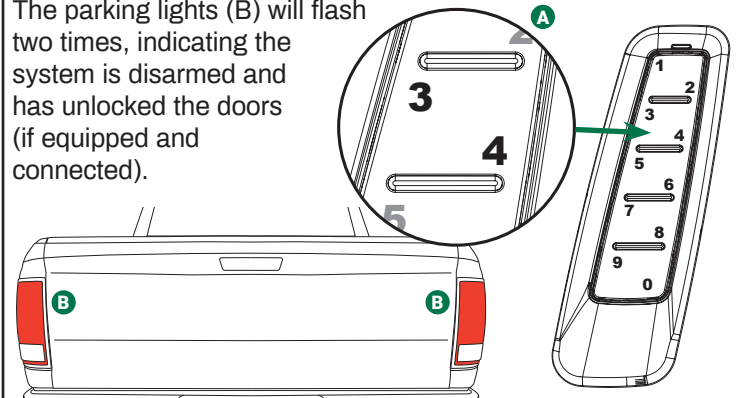

**8 To lock the vehicle:** Press and hold the 7/8 and 9/0 (A) buttons simultaneously until the green LED

(B) turns on. The parking lights (C) will flash once, indicating the system has locked the doors (if equipped and connected).

**Note:** The user does not need to unlock the keypad when locking the vehicle using the keypad.

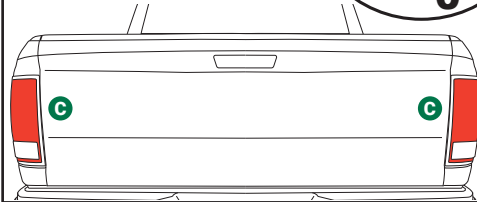
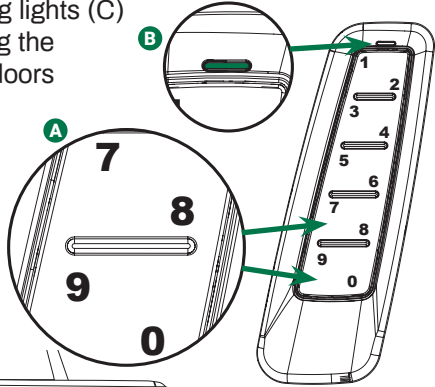

**9 To open the tonneau cover:**

1. Enter the 5-digit code.
2. Press and release the button 1/2 (A).

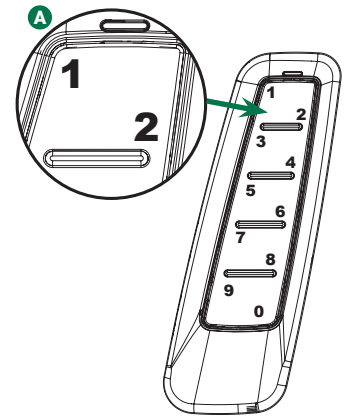

**10 To close the tonneau cover:**

1. Enter the 5-digit code.
2. Press and release the button 9/0 (A).

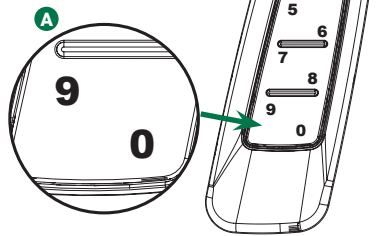

**11 To open or close the Tailgate (If applicable):**

1. Enter the 5-digit code.
2. Press and release the 5/6 button (A).

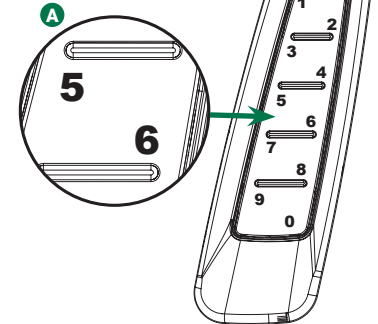

This handy access code card comes in the 5 digit keypad box when purchased.



**UNLOCK ALL DOORS:** Press the 3/4 key within 5 seconds of entering the 5-digit access code.

**LOCK ALL DOORS:** Press and hold 7/8 and 9/0 buttons simultaneously for at least 2 seconds.

**OPEN COVER:** Press 1/2 key within 5 seconds of entering the 5-digit access code.

**CLOSE COVER:** Press 9/0 key within 5 seconds of entering the 5-digit access code.

**OPERATE THE TAILGATE:\*** Press the 5/6 key within 5 seconds of entering the 5-digit access code.

\*Powered tailgates only.

**ACCESS CODE**

#####

**800-206-4070**

**LIMITED WARRANTY**

**KEYPAD – 36-MONTH LIMITED WARRANTY**

Retrax (the Company) warrants to the original purchaser of this product that should this product or any part thereof, under normal use and conditions, be proven defective in material or workmanship within 36 months from the date of original purchase, such defect(s) will be repaired or replaced with a new or reconditioned product, (at the Company's option) without charge for parts or repair labor. A transmitter for a vehicle security or remote start system is warranted for 12 months from the date of the original purchase.

To obtain repair or replacement within the terms of this Warranty, the product is to be delivered with proof of warranty coverage (e.g. dated bill of sale), authorization number, specification of defect(s), and transportation prepaid, to an approved warranty station. This warranty is not transferable. To obtain repair or replacement within the terms of this warranty, please call 1-800-206-4070 to acquire an RMA number.

This Warranty does not cover damage to the vehicle's electrical system or costs incurred for the installation, removal, or reinstallation of the product. This Warranty does not cover batteries, broken LCD transmitter display screens, nor apply to any product or part thereof which, in the opinion of the Company, has suffered or been damaged through alteration, improper installation, mishandling, misuse, abuse, neglect, accident, or by removal or defacement of the factory serial number/bar code label(s).

This Warranty is in lieu of all other express warranties or liabilities. ANY IMPLIED WARRANTIES, INCLUDING ANY IMPLIED WARRANTY OF MERCHANTABILITY, SHALL BE LIMITED TO THE DURATION OF THIS WRITTEN WARRANTY. ANY ACTION FOR BREACH OF ANY WARRANTY HEREUNDER INCLUDING ANY IMPLIED WARRANTY OF MERCHANTABILITY MUST BE BROUGHT WITHIN A PERIOD OF 24 MONTHS FROM DATE OF ORIGINAL PURCHASE. IN NO CASE SHALL THE COMPANY BE LIABLE FOR ANY CONSEQUENTIAL OR INCIDENTAL DAMAGES FOR BREACH OF THIS OR ANY OTHER WARRANTY. No person or representative is authorized to assume for the Company any liability other than expressed herein in connection with the sale of this product.

The Company does not warrant that this product cannot be compromised or circumvented. THE EXTENT OF THE COMPANY'S LIABILITY UNDER THIS WARRANTY IS LIMITED TO THE REPAIR OR REPLACEMENT PROVIDED ABOVE AND, IN NO EVENT, SHALL THE COMPANY'S LIABILITY EXCEED THE PURCHASE PRICE PAID BY PURCHASER FOR THE PRODUCT WITHOUT INSTALLATION LABOR.

Some states do not allow limitations on how long an implied warranty lasts or the exclusion or limitation of incidental or consequential damage so the above limitations or exclusions may not apply to you. This Warranty gives you specific legal rights and you may also have other rights which vary from state to state.

#### **TRANSMITTER – 12-MONTH LIMITED WARRANTY**

Retrax (the Company) warrants to the original purchaser of this product that should this product or any part thereof, under normal use and conditions, be proven defective in material or workmanship within 12 months from the date of original purchase, such defect(s) will be repaired or replaced with a new or reconditioned product, (at the Company's option) without charge for parts or repair labor. A transmitter for a vehicle security or remote start system is warranted for 12 months from the date of the original purchase.

To obtain repair or replacement within the terms of this Warranty, the product is to be delivered with proof of warranty coverage (e.g. dated bill of sale), authorization number, specification of defect(s), and transportation prepaid, to an approved warranty station. This warranty is not transferable. To obtain repair or replacement within the terms of this warranty, please call 1-800-206-4070 to acquire an RMA number.

This Warranty does not cover damage to the vehicle's electrical system or costs incurred for the installation, removal, or reinstallation of the product. This Warranty does not cover batteries, broken LCD transmitter display screens, nor apply to any product or part thereof which, in the opinion of the Company, has suffered or been damaged through alteration, improper installation, mishandling, misuse, abuse, neglect, accident, or by removal or defacement of the factory serial number/bar code label(s).

This Warranty is in lieu of all other express warranties or liabilities. ANY IMPLIED WARRANTIES, INCLUDING ANY IMPLIED WARRANTY OF MERCHANTABILITY, SHALL BE LIMITED TO THE DURATION OF THIS WRITTEN WARRANTY. ANY ACTION FOR BREACH OF ANY WARRANTY HEREUNDER INCLUDING ANY IMPLIED WARRANTY OF MERCHANTABILITY MUST BE BROUGHT WITHIN A PERIOD OF 24 MONTHS FROM DATE OF ORIGINAL PURCHASE. IN NO CASE SHALL THE COMPANY BE LIABLE FOR ANY CONSEQUENTIAL OR INCIDENTAL DAMAGES FOR BREACH OF THIS OR ANY OTHER WARRANTY. No person or representative is authorized to assume for the Company any liability other than expressed herein in connection with the sale of this product.

The Company does not warrant that this product cannot be compromised or circumvented. THE EXTENT OF THE COMPANY'S LIABILITY UNDER THIS WARRANTY IS LIMITED TO THE REPAIR OR REPLACEMENT PROVIDED ABOVE AND, IN NO EVENT, SHALL THE COMPANY'S LIABILITY EXCEED THE PURCHASE PRICE PAID BY PURCHASER FOR THE PRODUCT WITHOUT INSTALLATION LABOR.

Some states do not allow limitations on how long an implied warranty lasts or the exclusion or limitation of incidental or consequential damage so the above limitations or exclusions may not apply to you. This Warranty gives you specific legal rights and you may also have other rights which vary from state to state.

---

#### **FCC compliance**

This device complies with Part 15 of the FCC rules. Operation is subject to the following two conditions:

- 1) This device may not cause harmful interference, and
- 2) This device must accept any interference received, including any interference that may cause undesired operation.

#### **WARNING!**

Changes or modifications not expressly approved by the party responsible for compliance could void the user's authority to operate the equipment.

#### **Radiation Exposure Statement:**

This equipment complies with IC radiation exposure limits established for an uncontrolled environment. This equipment must be installed and operated with a minimum distance of 20 cm between the radiation source and your body.