

Part # 9000101

**Components and Hardware:**

1.

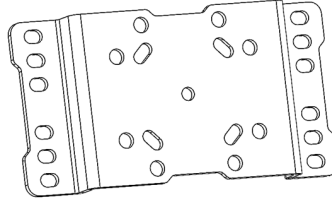

2.

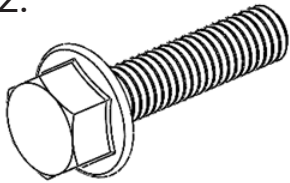

3.



4.

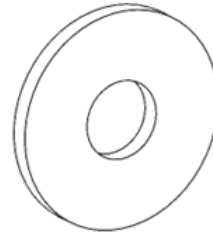

**Components and Hardware:**

- 1. Molle Tool Adapter, Small.....(1)
- 2. M6 Flange Bolt.....(4)
- 3. M6 Locking Flange Nut.....(4)
- 4. M8 Flat Washer.....(8)

**Tools for Installation:**

- 10mm Wrench
- 10mm Ratchet

**Mount Options:**

**Mounting options for the Molle Tool Adapter**



# Molle Tool Adapter, Small

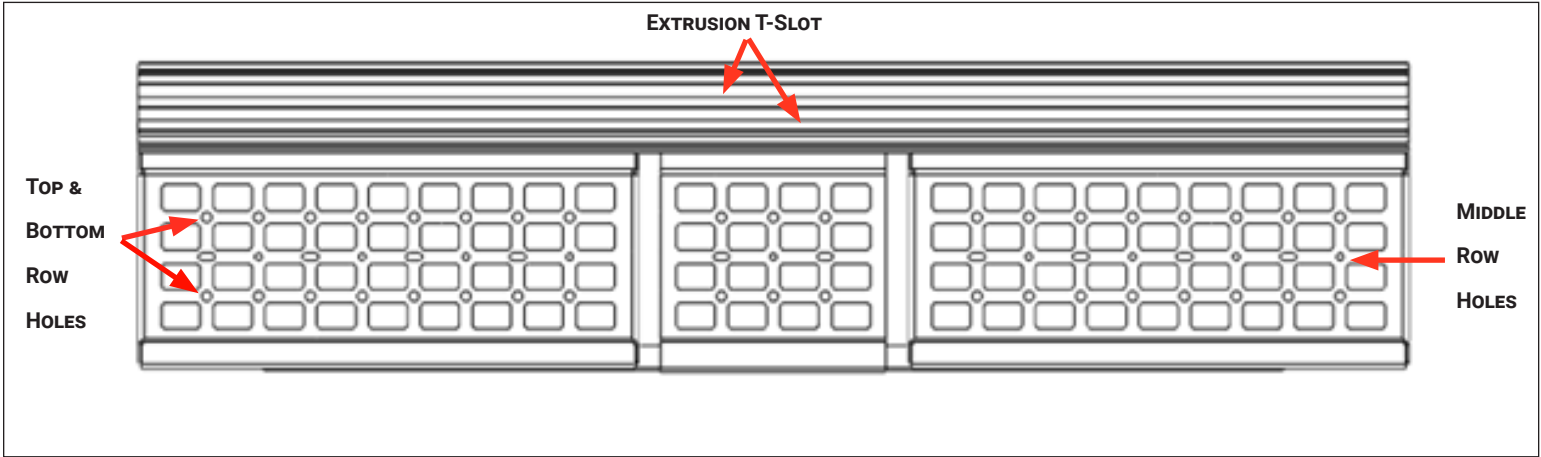

Using provided hardware, M6 Flange Bolts (#2), M8 Flat Washers (#4) and M6 Locking Flange Nuts (#3), attach the Molle Tool Adapter, Small (#1) to your desired location on the Molle Panel. The lowest mounting position requires using the middle and bottom row holes. The middle mounting position requires using the top and bottom row holes. The highest mounting position requires using the middle and top row holes. See images shown.

The Molle Tool Adapter, Small (#1) can accept small to medium rubber clamp mounts.

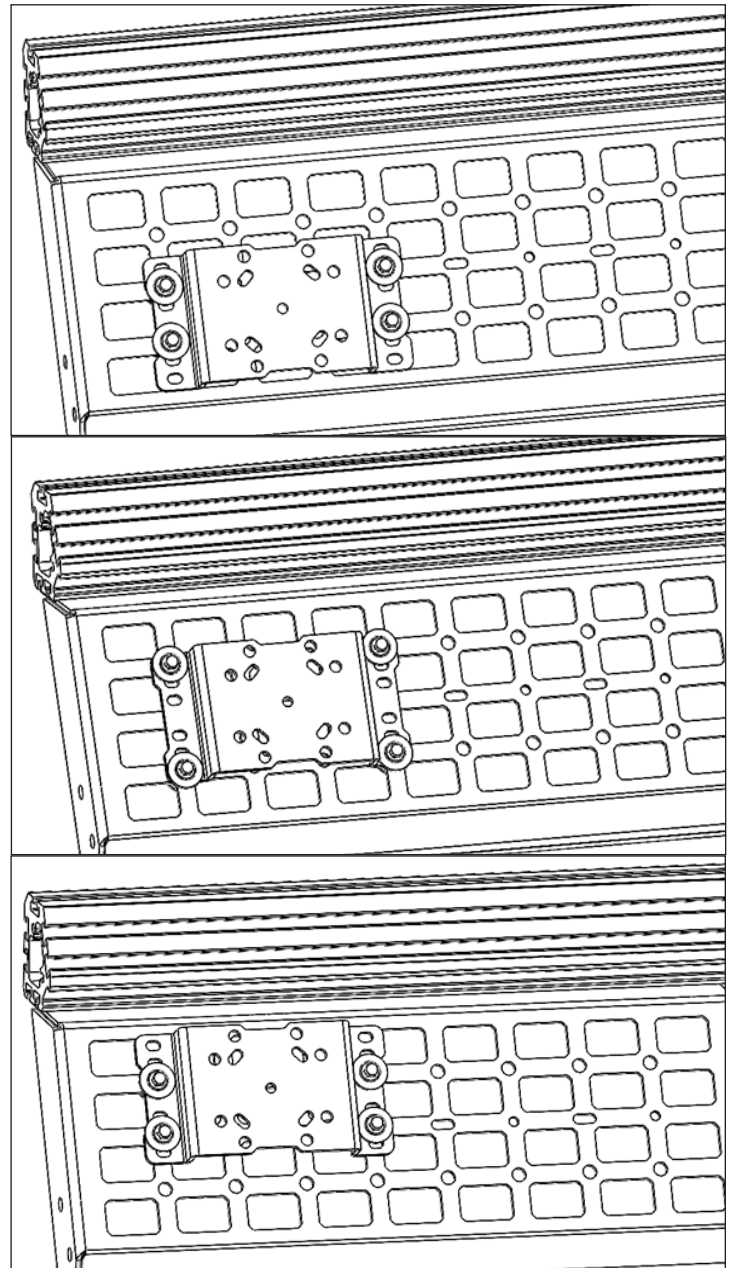
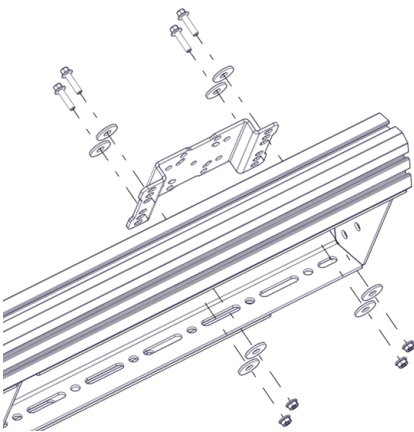

## Molle Tool Adapter, Small

If mounting to an extrusion, slide 2 T-Nuts (not included) into the top slot of the extrusion and align with centered slots in the Molle Tool Adapter, Small (#1). This position will utilize the middle row holes and slots along with the top extrusion slot.

