

CUSTOMER SERVICE

PHONE: 800-206-4070, Mon - Fri 8:00 am - 5:00 pm central

EMAIL: retrax@retrax.com

TOOLS REQUIRED

- Scissors or utility knife
- Isopropyl alcohol
- Spray Bottle w. Soapy Water
- T30 Screwdriver
- T20 Screwdriver
- 1/2" & 5/8" Drill bit
- Drill
- Tape Measure
- Torque wrench 7-18 ft-lb
- Drill bit & drill

TOOLS RECOMMENDED

- Hammer
- Pick or small screwdriver

NOTE: It is important that all areas where the bed cover mounts are clean and free of debris prior to installing. Installing the roll cover will require 2 people.

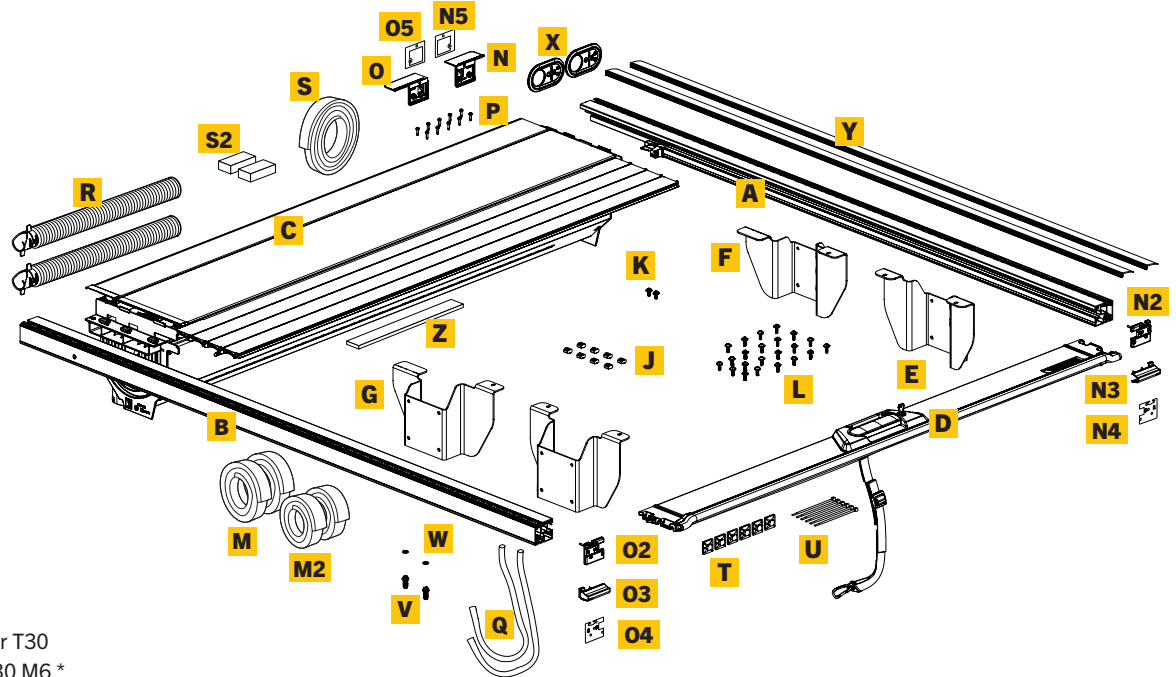

PARTS INCLUDED

- A** 1x Passenger side rail
- B** 1x Driver side rail
- C** 1x Roll cover
- D** 1x Tailgate rail
- E** 2x Middle brackets *
- F** 1x Right Front bracket *
- G** 1x Left Front bracket *
- J** 8x T-stones for bracket
- K** 2x Bolts for side rail to canister T30
- L** 22x Lower bolts for bracket T30 M6 *
- M** 2x Side rail sealing foam Long *
- M2** 2x Side rail sealing foam Short *
- N** 1x Right front corner
- N2** 1x Right rear corner
- N3** 1x Right rear corner rubber
- N4** 1x Right rear corner foam
- N5** 1x Right front corner foam
- O** 1x Left front corner
- O2** 1x Left rear corner
- O3** 1x Left rear corner rubber
- O4** 1x Left rear corner foam
- O5** 1x Left front corner foam
- P** 10x Front/Rear corner screw T20
- Q** 2x Rear drain tube
- R** 2x Front drain tube *
- S** 1x Canister foam seal
- S2** 2x Side rail front foam seal
- T** 6x Cable tie mount
- U** 6x Cable tie
- V** 2x Rear drain connector
- W** 2x O-ring
- X** 2x Front drain grommet *
- Y** 2x Side rail rubber cover
- Z** 2x Canister plastic bracket foam seal

Disclaimer: Aftermarket spray-in bedliners might not be compatible due to thickness and sealing issue.

Before Installation: Remove accessories that might be in the way of the rollcover like grab-assist handles.

Vehicle fitment chart

Ford F-150 5.6' 2015-YTD

Ford F-150 6.6' 2021-YTD

Ford F-150 6.7' 2015-2020

Ford F-250/F-350 6.8' 2017-YTD

* Parts (amount & type) may vary depending on vehicle model.

Detailed view

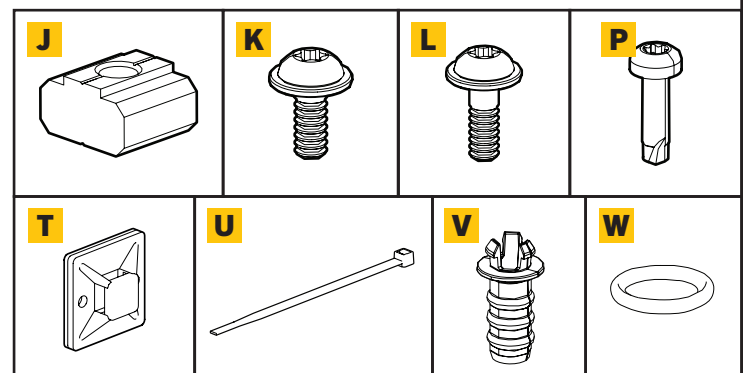

PREPARING THE TONNEAU COVER

- 1** First slide the T-Stones* (J) into each front of the side rails (there should be an equal amount in each side and 2 t-stone should be saved for step 2), slide the T-Stones to about the middle of the rails (these will be used for the brackets). Slide the side rails into the canister top until they stop. It is recommended to assemble the roll cover on a table and some boxes or foam to support the side rails.

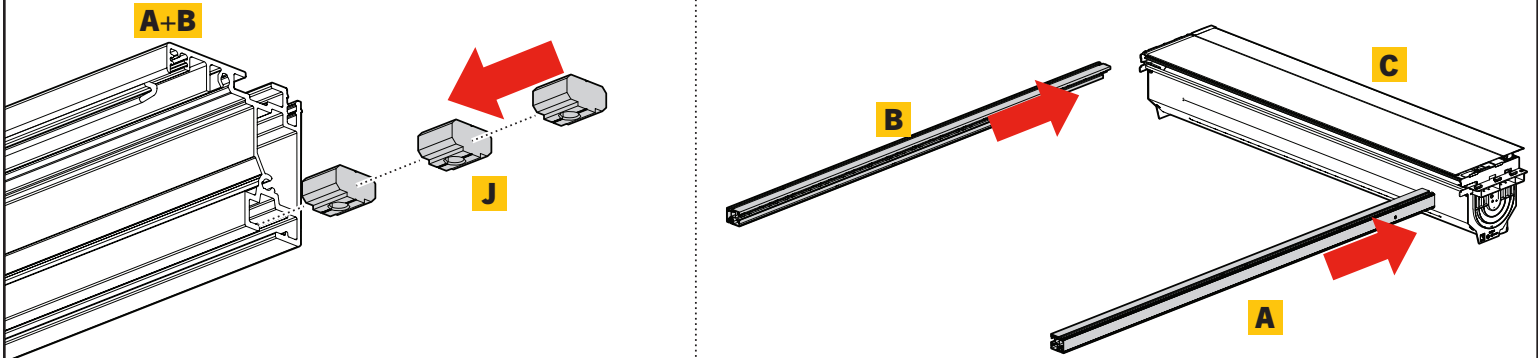

*NOTE: Amount of t-stones depends on the vehicle model.

- 2** Place a t-stone (J) in the left and right side rails. Slide the t-stones in until they stop. Then mount the screw (K) with a torque of 3.5 ft-lbs.

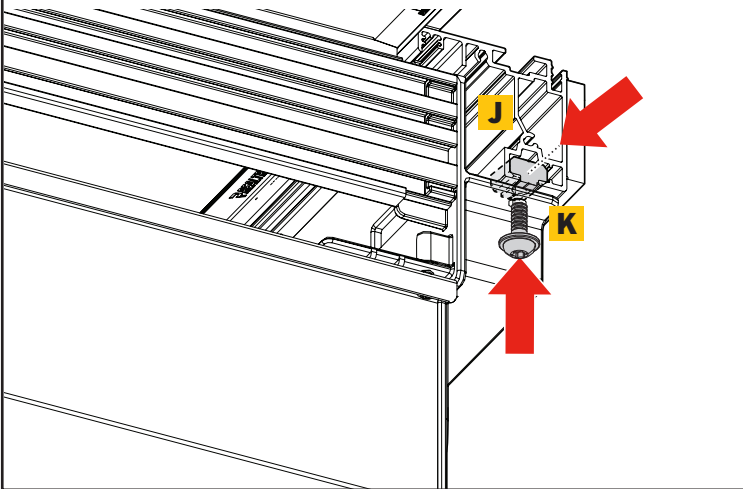

- 3** Apply the foam (O5 + N5), first take the glue liner off. Attach the left and right front plastic corner (N + O) to the side rails.

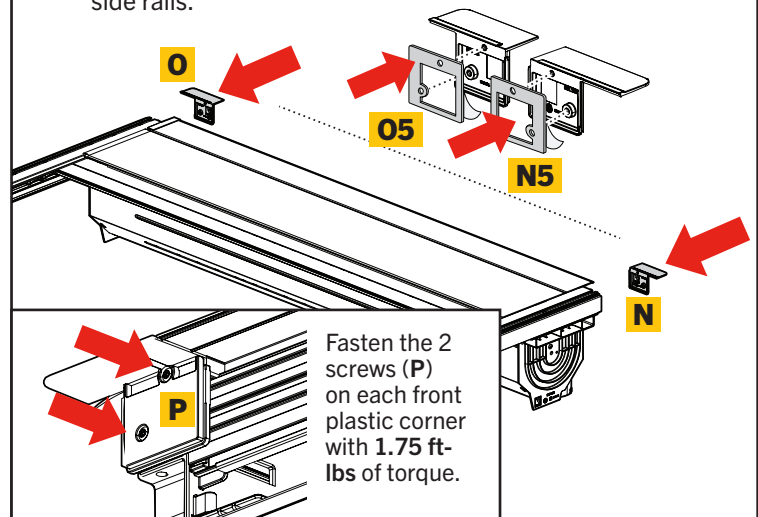

- 4** Pull the roll past the rear of the side rails, make sure not to let go of the carpet as it will roll back and loose tension.

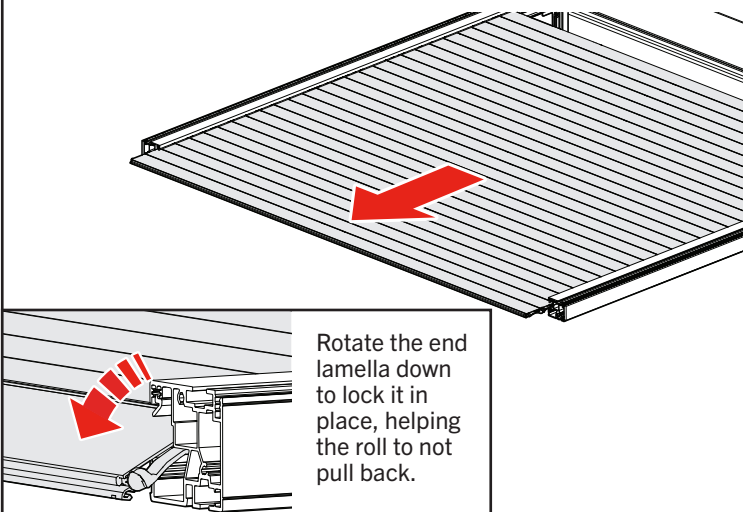

- 5** Slide the tailgate profile (D) into the lamella on an angle until they are aligned with the end of the lamella.

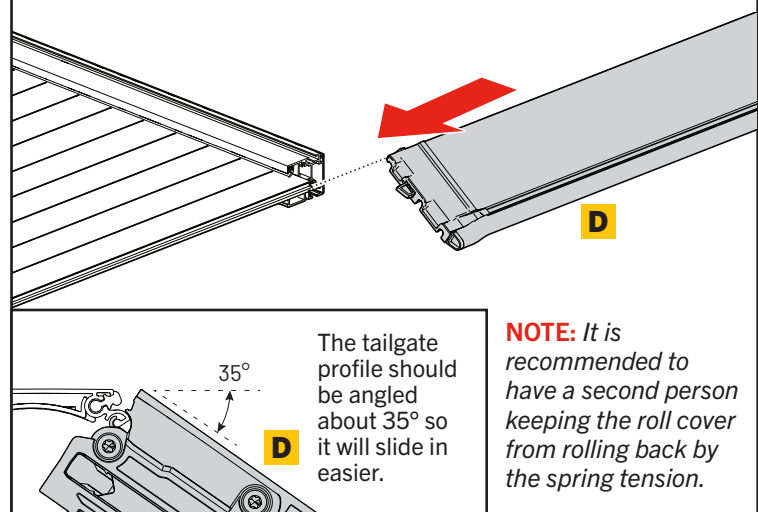

6 Rotate the tailgate profile and push it forward. This will engage the lock and make a click sound.

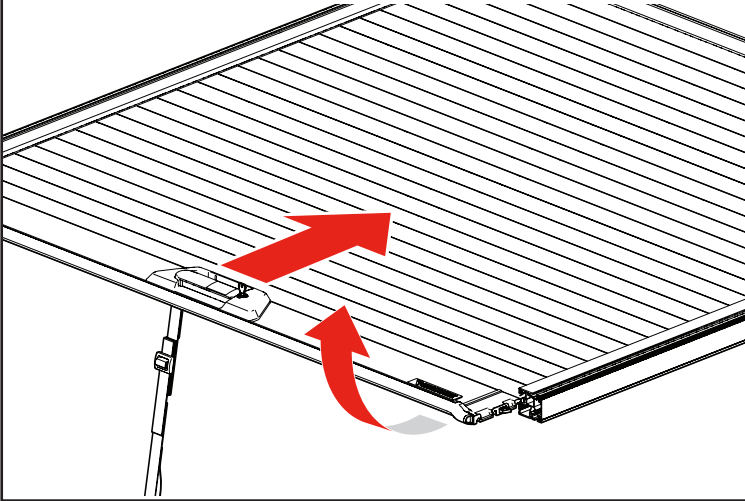

7 The roll cover will open by itself from the spring tension.

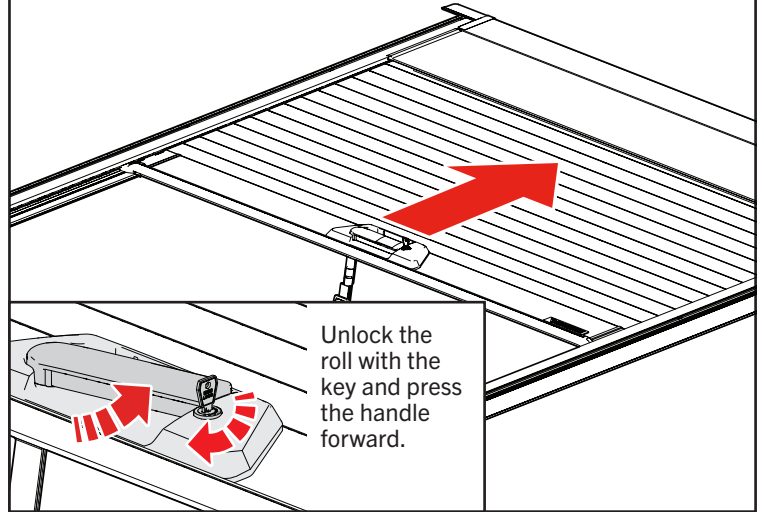

8 Attach the right and left rear plastic rubbers (N3 + O3) to the plastic corners by pulling the tabs until it clicks in, make sure that the rubber is not bent. Pull the glue liner off from the right and left rear foams (N4 + O4) and attach to the rear plastic corners (N2 + O2)

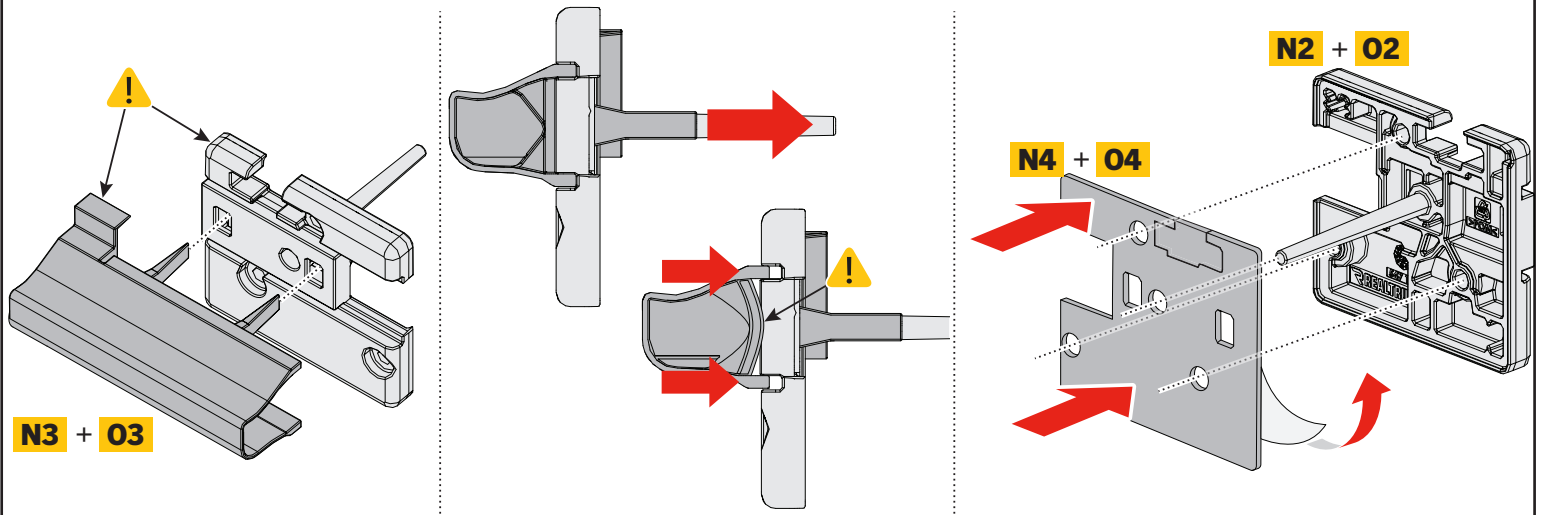

9 Attach the right and left rear plastic corner (N2 + O2) to the side rails. Fasten the 3 screws (P) on each rear plastic corner with 1.75 ft-lbs of torque. Pull the foam piece off by the t-stone slot.

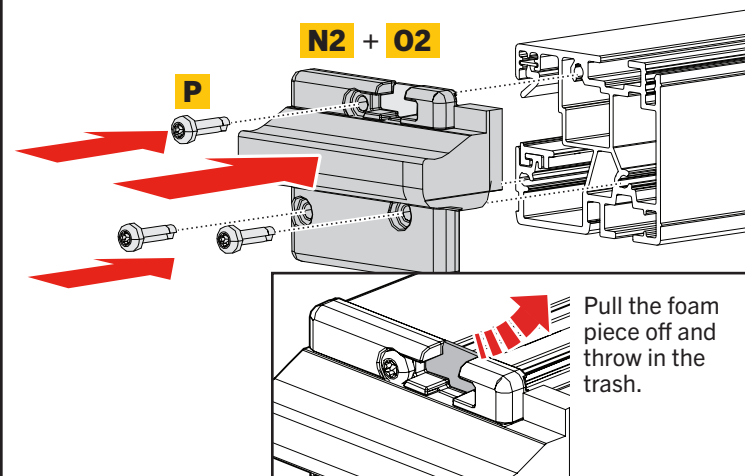

10 Mount the left and right front drain (R) to the canister ends.

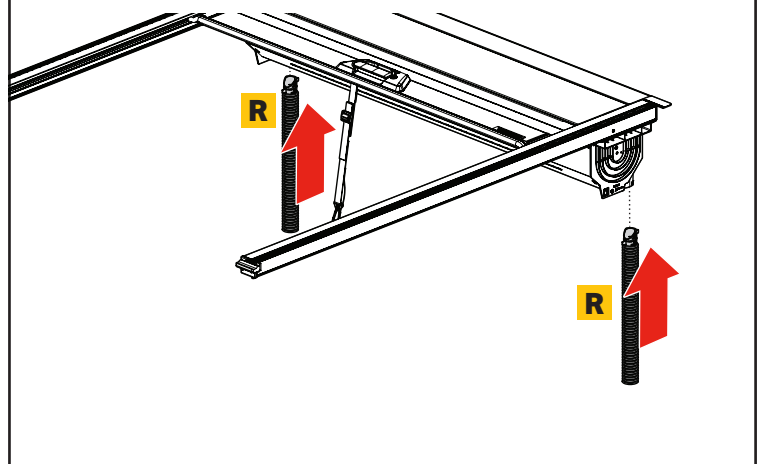

11 Place the foam (Long+Short) (**M or M2**) so it sits flush with the plastic part of the front of the side rail. The top edge of the foam is to be positioned below the line on the profile, that is 1/8" down from the top of the profile.

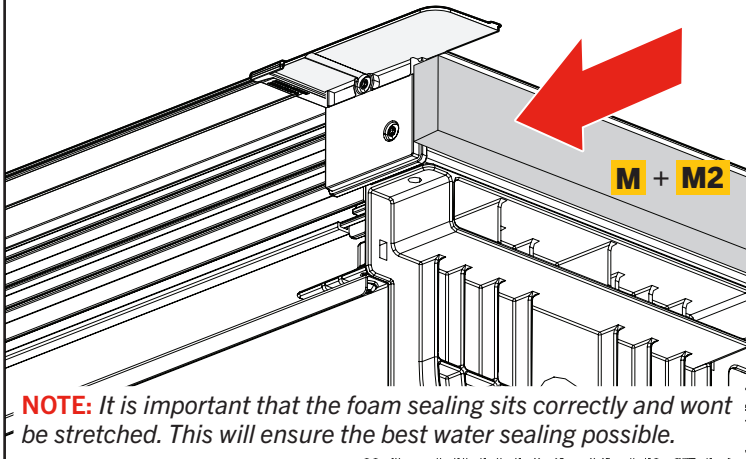

12 The foam (**S2**) should be flush with the outer edge of the side rail sealing foam (**M or M2**).

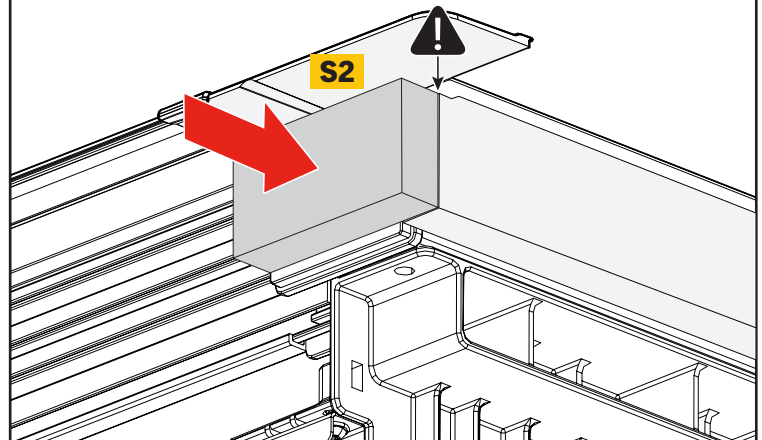

13 Apply the rest of the foam (Long or Short) (**M or M2**) to the left and right side rails. Align it to the top most line. Push the two foams together so there wont be a gap. Depending on you vehicle model different amounts of the foams are included (e.g. 2x **M**). You might need to cut the foam to length at the end.

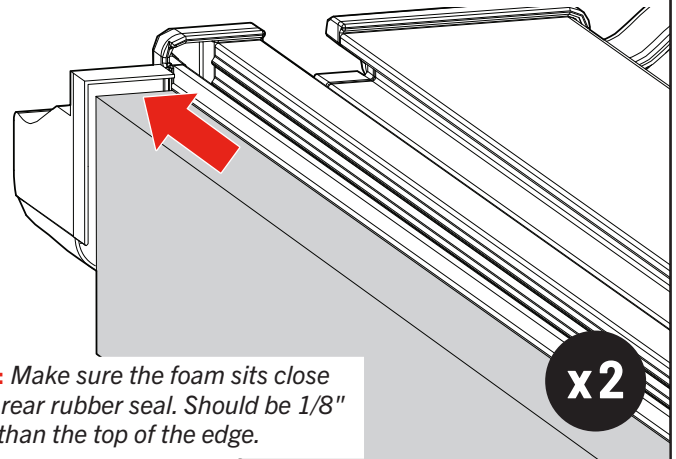
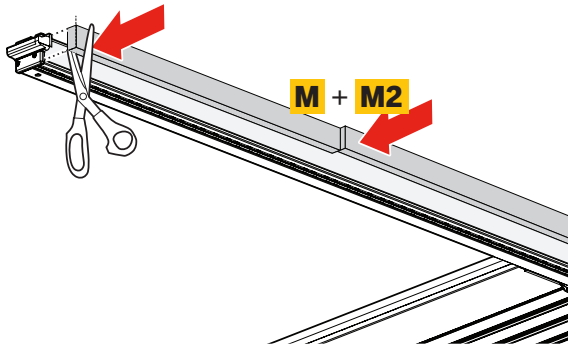

14 Apply the foam (**S**) to the canister and side rail end cap and canister lid. Foam (**S2**) should be behind foam (**S**).

NOTE: Make sure to not stretch the foam, as it can cause it to not line up properly.

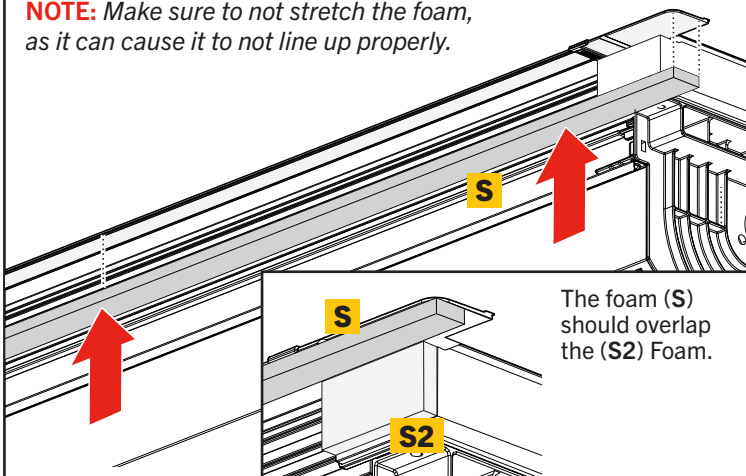

15 Apply the foam (**Z**) to the canister end cap bottom.

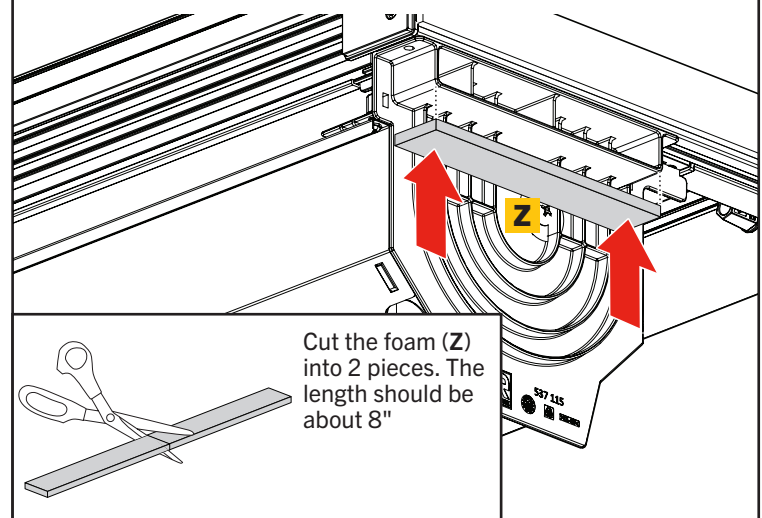

MOUNTING THE BRACKETS

- 16** Make sure to uninstall any accessory like cargo management rails. If your vehicle has no accessory rail, disregard this step.

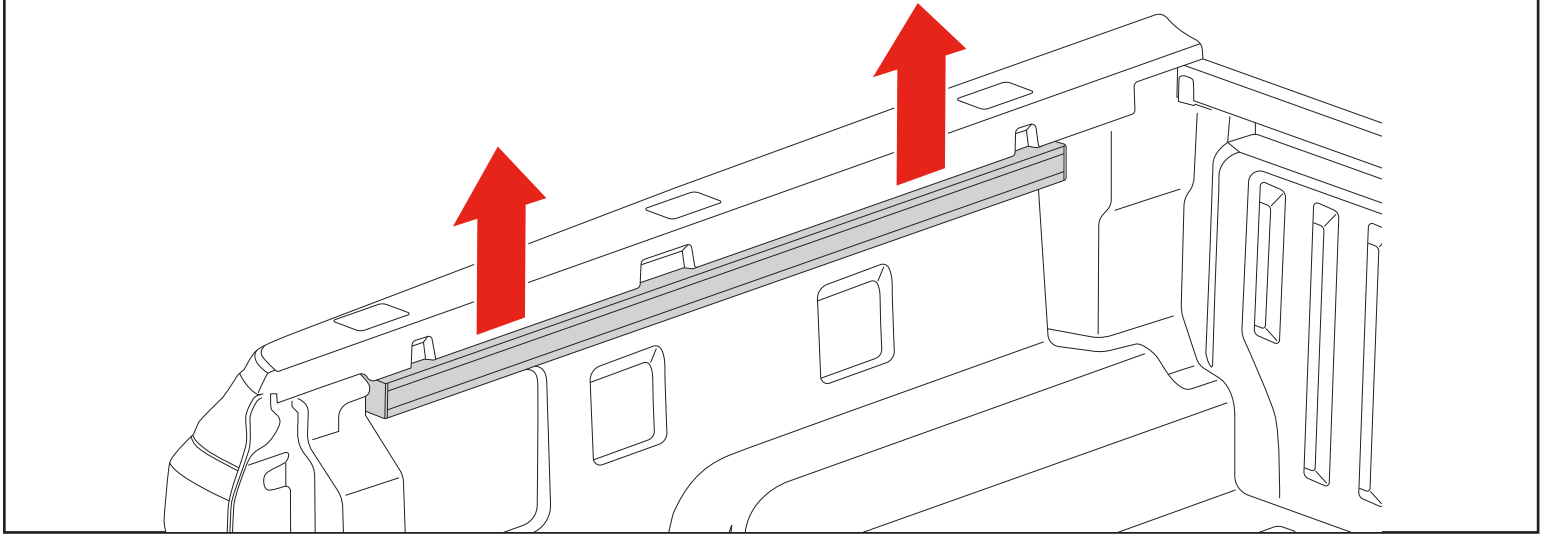

- 17** Mount the 4 brackets (G, F & 2x E) to the vehicle bed. Mount the bolt (L) and use a torque wrench*.

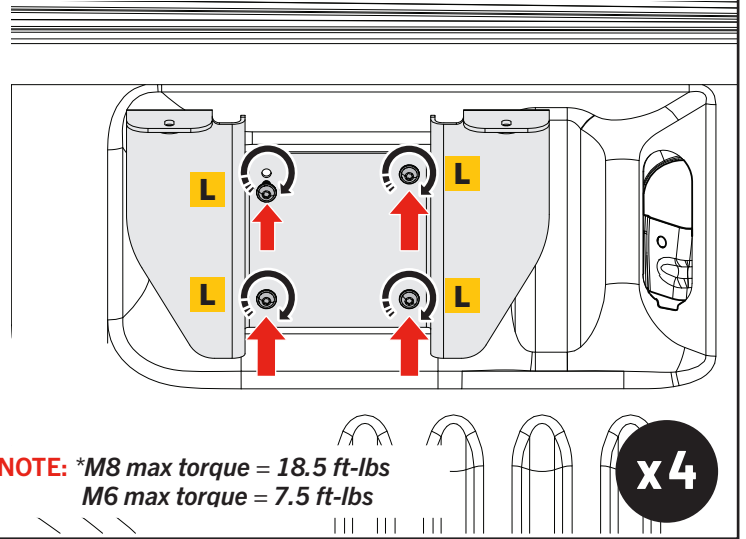
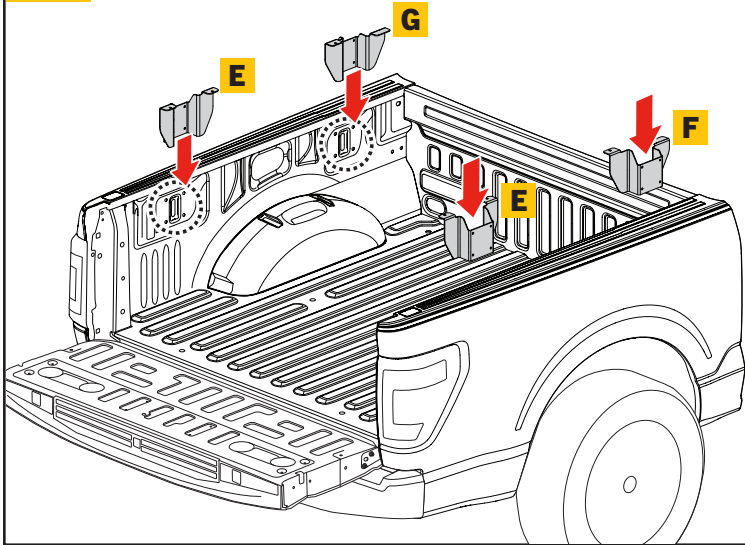

MOUNTING THE TONNEAU COVER

- 18** Hold the cover about ½" above the brackets. Push the roll cover forward until it stops against the bulkhead, this should make it straight, and compress the front corner foam. Now place it down on the brackets. Make sure the T-Stones are right above the bracket holes. If not, place the t-stones so they are right above the holes on the bracket.

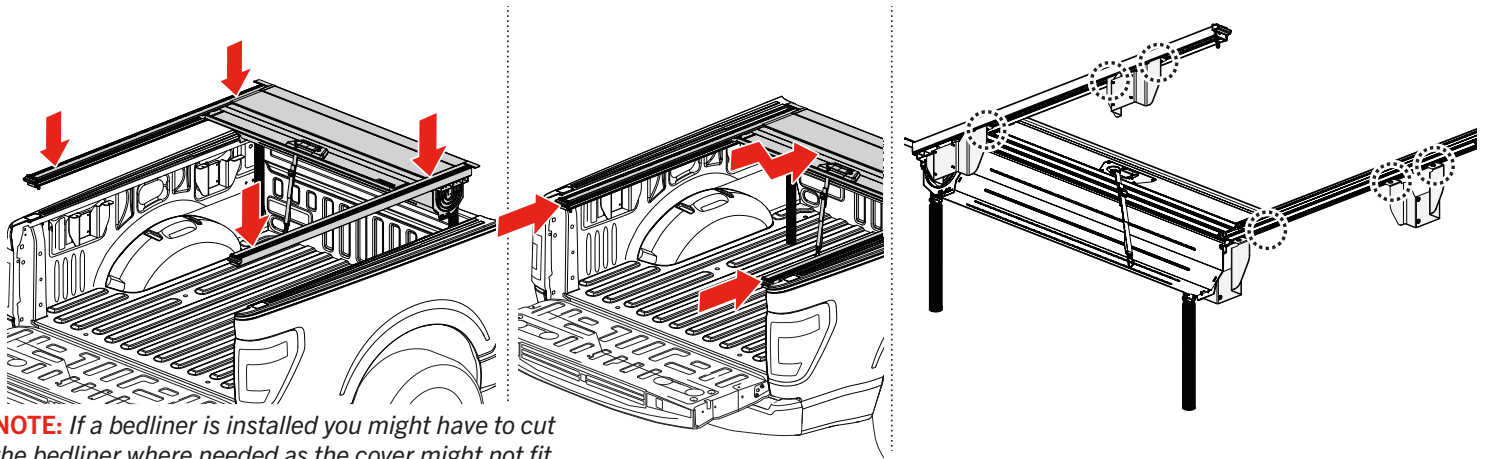

- 19** Lock the lid by pushing it out towards each side rail.

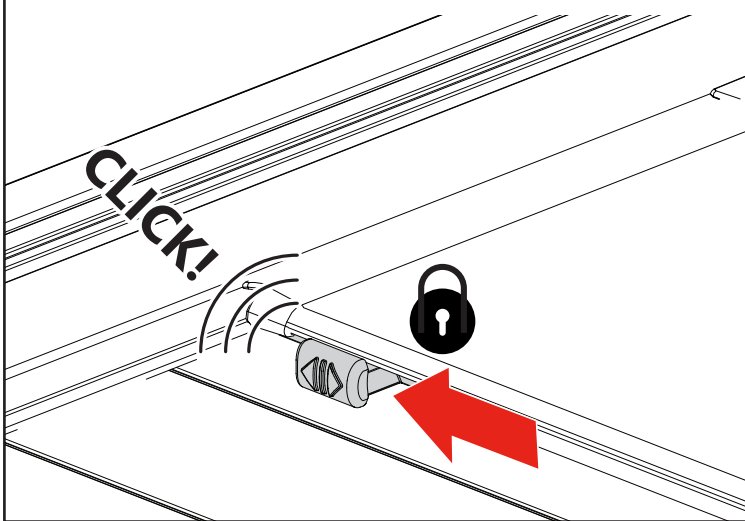

- 20** Position the t-stone above each hole. Lightly fasten the bolt (L) to the bracket and side rails. Do the same on all brackets. Pull the roll cover back so there is a 3/8" gap between tailgate and rear corner, rubber seal should still touch.

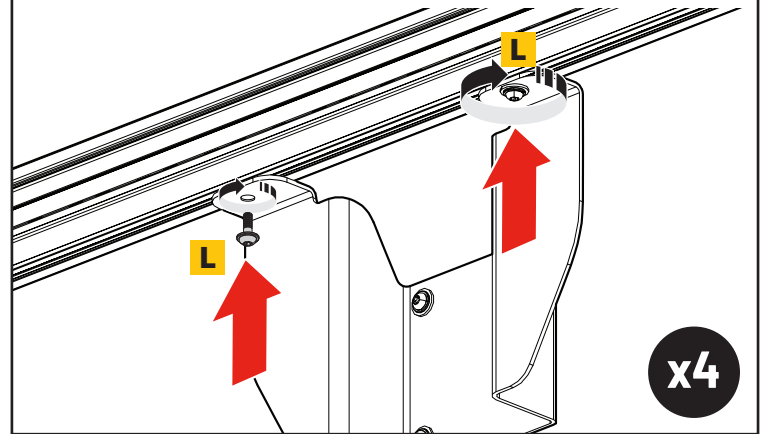

- 21** Mount the O-ring to the rear drain connector. Then click it into place under the rear end side rail. Repeat for the opposite side.

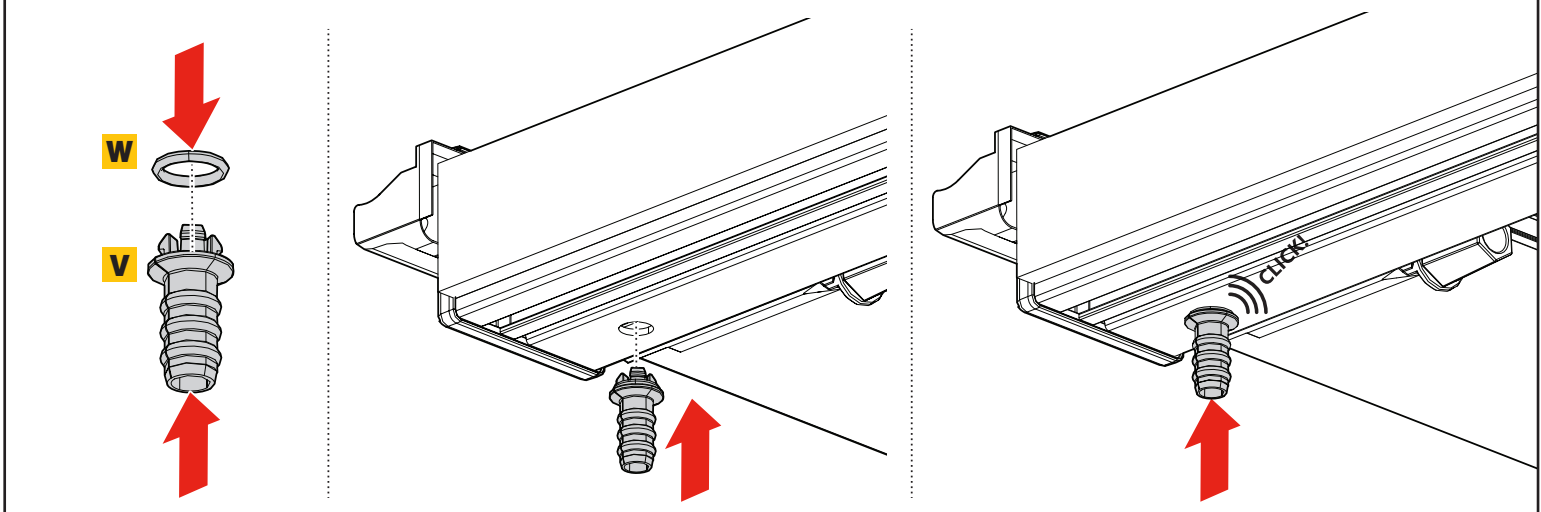

22 Attach the rear drain to the plastic connector. Close the tailgate and identify the gaps between tailgate and bed. Tape the drain where the final position will be. Make sure the drain tube is routed so it won't be pinched by the tailgate when closing, use tape where you will mount the cable tie mounts. Test it by opening and closing the tailgate. Press the cable tie mount in place as shown and fasten the drain with cable ties. Lastly, cut the excess hose at the tailgate gap. Do this on both sides.

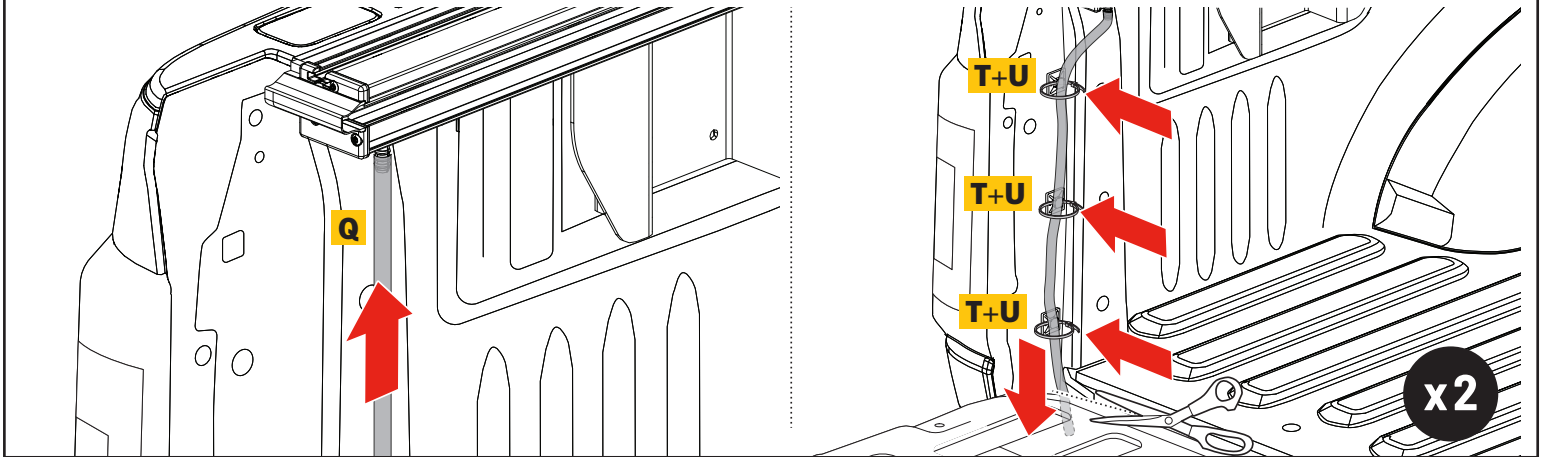

23 Mount the drain tubes (R) through the existing hole in the factory bed. The drain hose might need to be cut so it won't hang when attached to the drain hole. Attach the front drain grommets (X) the left and right front drains (R). Then mount the drain and grommet to the truck bed.

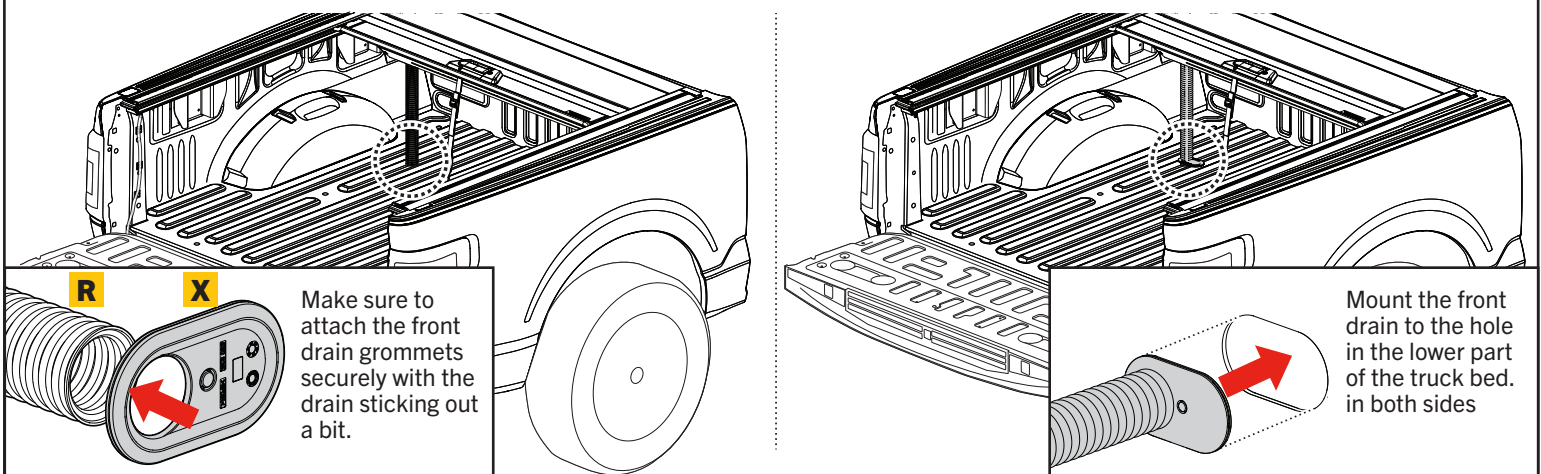

24 Parallel measure the roll cover A should be the same as B. Cross measure the roll cover C should be the same as D. This will make sure that the roll cover sits properly, and ensures that it will roll back and forth with minimal friction.

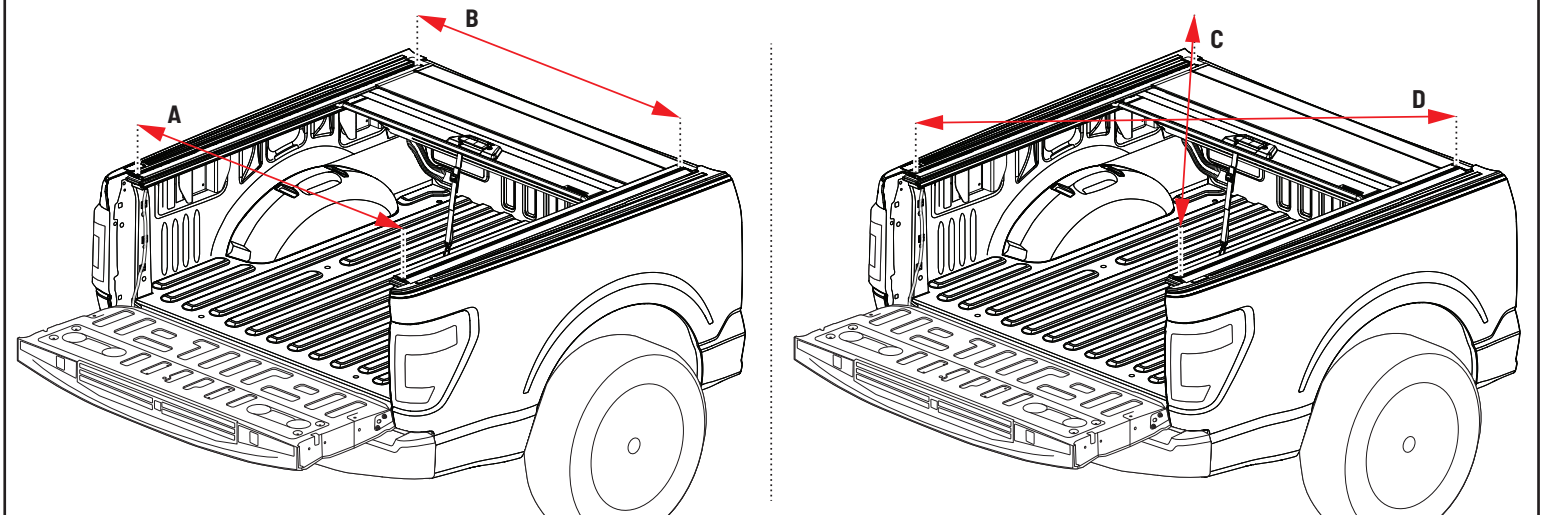

25 Fasten the bolt (L) and use a torque wrench*. Do the same on all brackets.

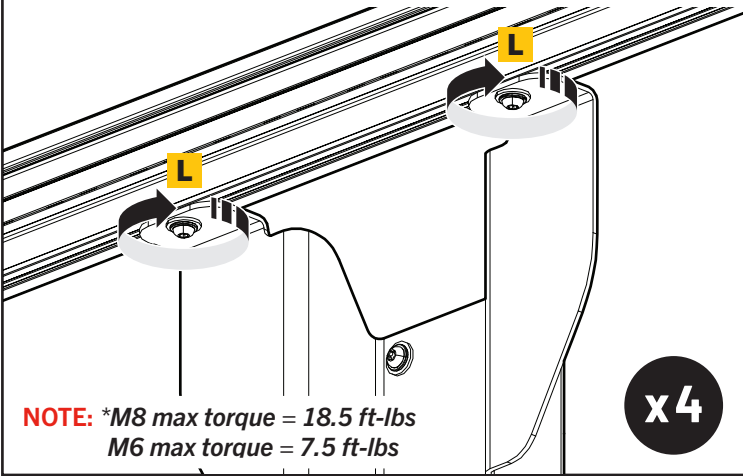

26 If tape underneath remove glue liner. Attach the rubber covers (Y) to the side rails. Use a cylindrical tool that can help push it down.

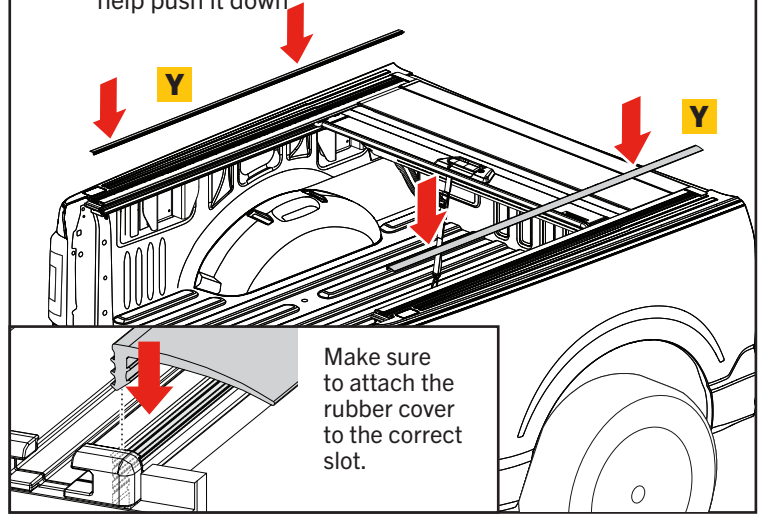

COVER USE

Open: Unlock your roll cover, then push the handle forward to unlock the hatch. Push the cover and the roll cover will open up from the spring tension inside the canister.

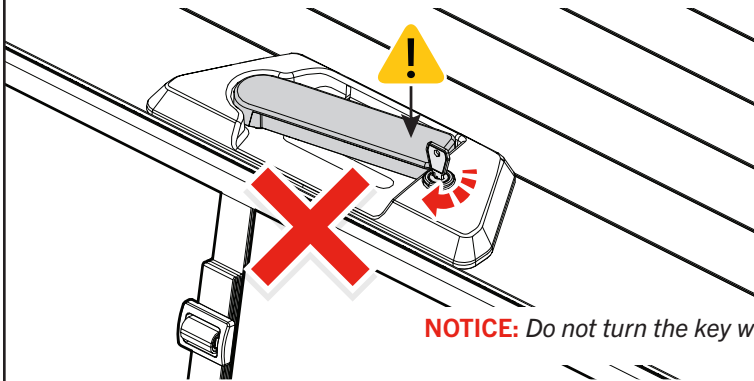

NOTICE: Do not turn the key while the handle is pushed forward.

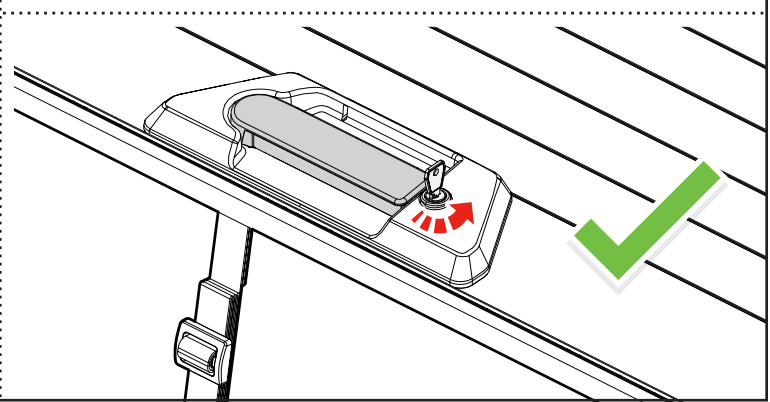
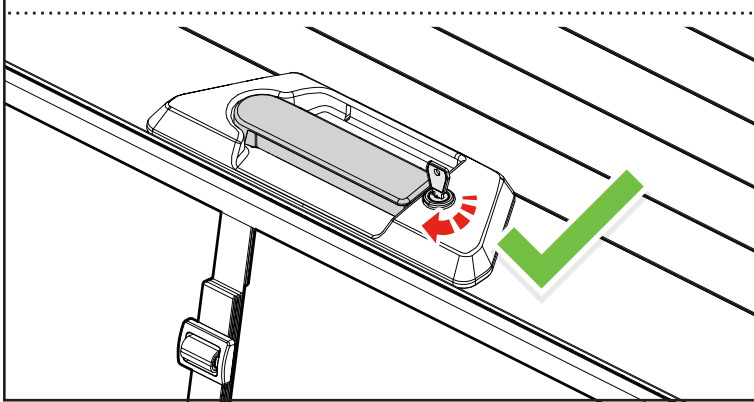
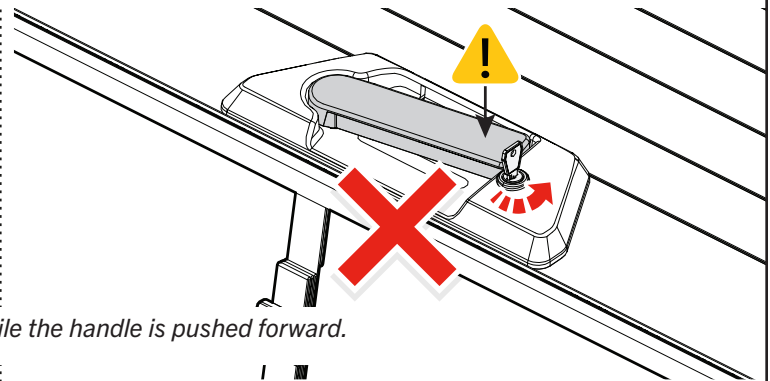

Close: Take the pull strap and pull it to the left and then to the middle to release the latches holding it open. Pull it back until it is fully closed. You know it is properly closed when the handle clicks back to its locked position.

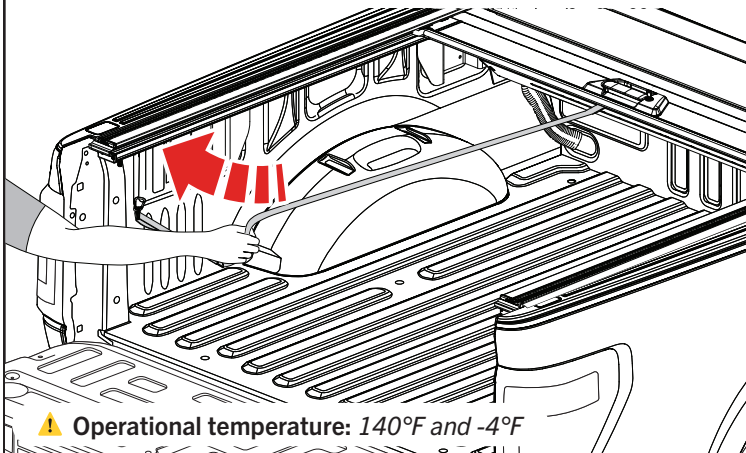

Operational temperature: 140°F and -4°F

Lock/Unlock Lid: Lock the canister lid when driving and going in a carwash. Unlock the lid when you need to clean the canister.

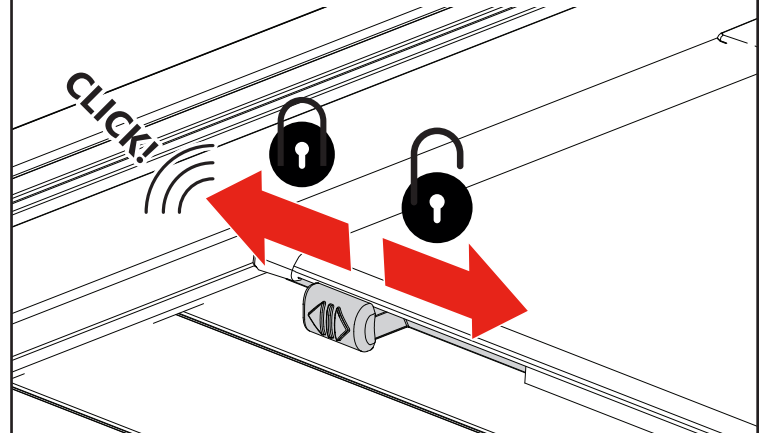

NOTICE: The lid should be locked before going in a carwash.

IMPORTANT NOTICE

This bed cover may retract to the full open position very quickly resulting in any objects placed on top of the bed cover to fall off the bed cover or become trapped inside of the bed cover carrier. Do not place ANY objects on top of the bed cover when attempting to close. Failure to follow the instruction may result in damage to your vehicle, belongings or bed cover. To avoid injury keep all body parts clear of the bed cover and carrier when opening.

COVER CARE AND MAINTENANCE

The truck bed cover requires occasional cleaning with mild automotive soap and water only. Avoid using abrasive cleaners as they may dull the finish. Some chemicals and fluids such as insect repellents, oils, solvents, and lubricants could potentially damage the rubber hinges and seals and void the warranty.

CAUTION

Always read the ingredients of any product you are using to clean your truck bed cover. Make sure that you use only products that are safe for use with rubber. Many cleaners contain chemicals that could permanently discolor or damage your hinges and seals.

Periodically check that your cover is securely attached to your truck bed and working as intended. Inspect all hardware such as clamps and cover retainer clamps to ensure they are properly installed and working as intended. Covers that are used at high frequency or subject to rough roadways and/or heavy vibration conditions may cause the cover to require adjustment.

It is also recommended that you regularly inspect and service each panel latch. Clean away any excess dirt or grime. Ensure all latches move freely in and properly engage the side rail to provide optimal performance and security.

MAINTENANCE

It is recommended that you periodically check that the cover is securely attached to your truck bed. Inspect the brackets and mounting bolts to ensure they were properly installed and have not come loose or knocked out of adjustment during operation.

Covers that are used with high frequency or that are subject to the vibrations and impact from rough roadways can cause the cover to require adjustment.

IMPORTANT: NEVER spray any lubricant into the tracks. THIS WILL VOID YOUR WARRANTY. Lubricants, especially silicone or petroleum-based, will attract dirt and debris which will lead to slow operation and will degrade the gaskets over time. If the tracks feel a little 'sticky', you may spray some latex protective spray inside the track and wipe with a clean rag to remove any dirt or debris that has built up.

HOUSING DRAINS

To ensure proper drainage, it is recommended that the canister housing be checked and cleared of any leaves, twigs or other debris that may obstruct the drain tubes.

SAFETY INSTRUCTIONS

- Do NOT place objects on or against cover or framework.
- Do NOT tie cargo to truck bed cover or framework.
- Do NOT operate vehicle with objects on top of the cover.
- NEVER allow children or pets to occupy the truck bed with the cover in the fully closed position.
- The cover is not airtight. Special care is required to keep cargo clean and dry.
- Truck bed covers will not prevent theft of contents inside the truck bed.

Use compressed air to remove any debris that could be causing your roll cover to not move smoothly.

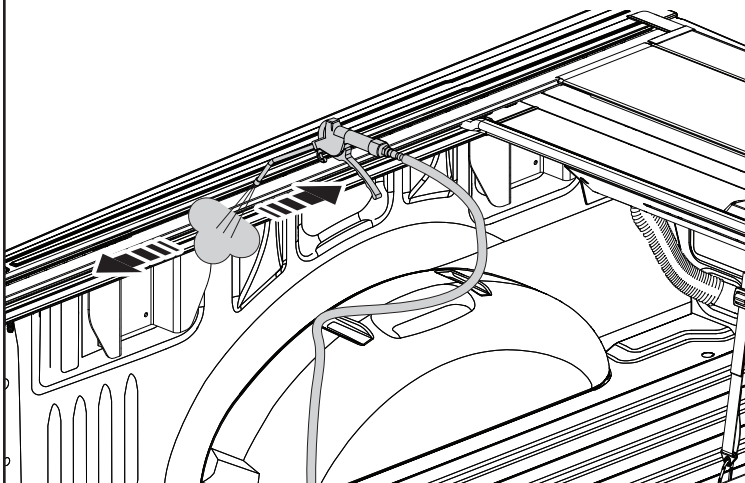

Use a wet sponge with soapy water to clean out any dirt.

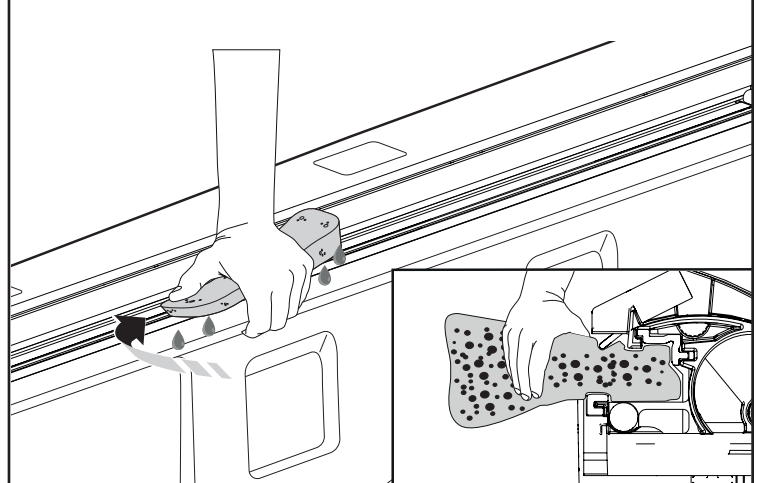

TROUBLESHOOTING TIPS

Check Glide Rail: If abnormal sounds occur during operation of the roll cover, inspect the glide rails for debris or damage. If the glide rails are damaged or worn, replacement glide rails are needed.

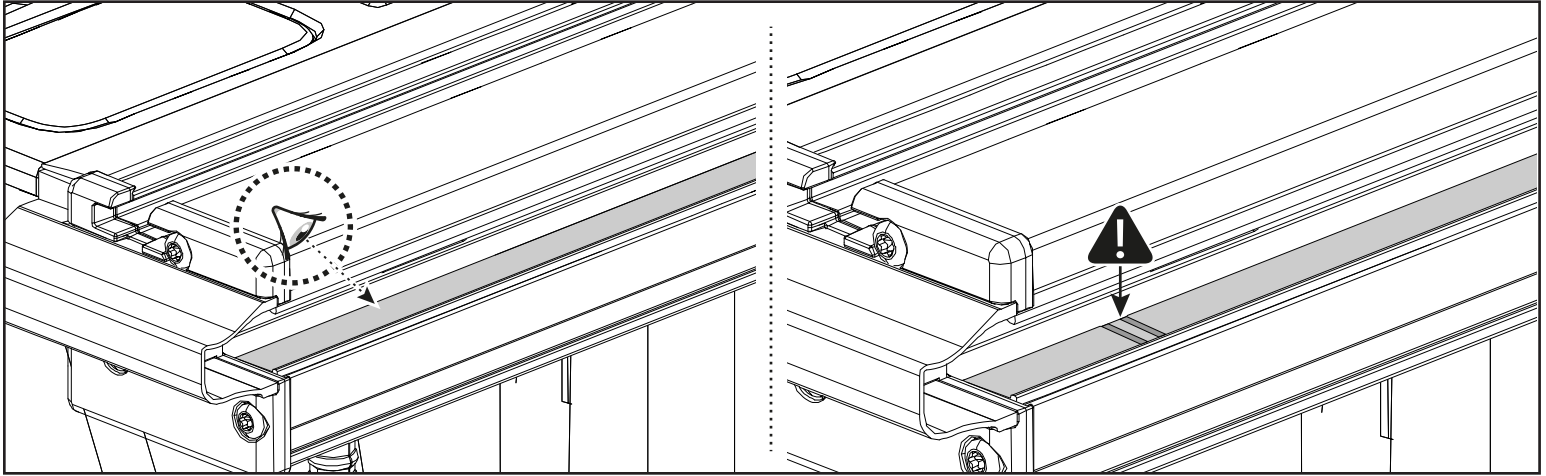

Wavy Side Seal: The seal may be wavy when removed from the box. Allow ample sunlight for seal to lay flat and relax.

Use of roll cover in freezing temperatures: Before operating you roll cover in freezing temperatures, use you fist to hit the lamellas enough so the ice will loosen. This will ensure minimal damage to the rubber between each lamella when operating.

Adjusting the spring tension: If your roll cover is not retracting as fast as it used to. You need to tighten the spring tension. Start by opening the tailgate, then follow the pictures below.

Disassemble the rear corners so we can get the roll cover past the tailgate.

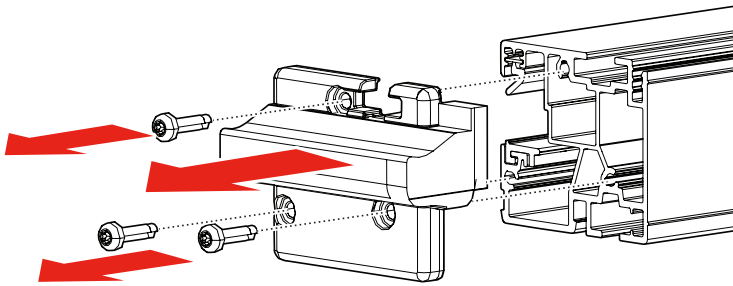

Pull the roll cover past the rear end, angle the rear profile down so it will bestuck and not roll back. Then open the canister lid.

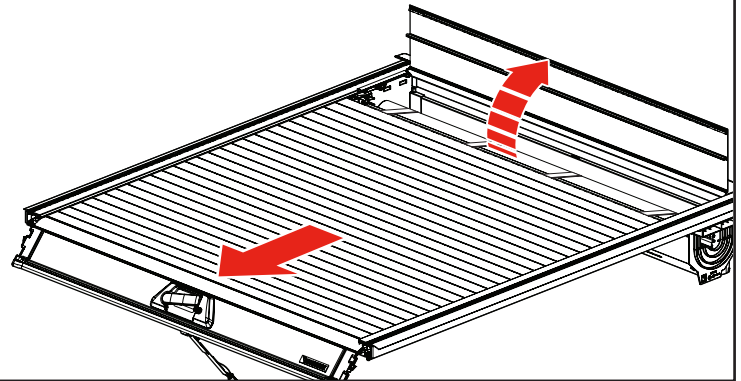

Click the lamella clips off, make sure you are holding the spring axel before clicking the last one off.

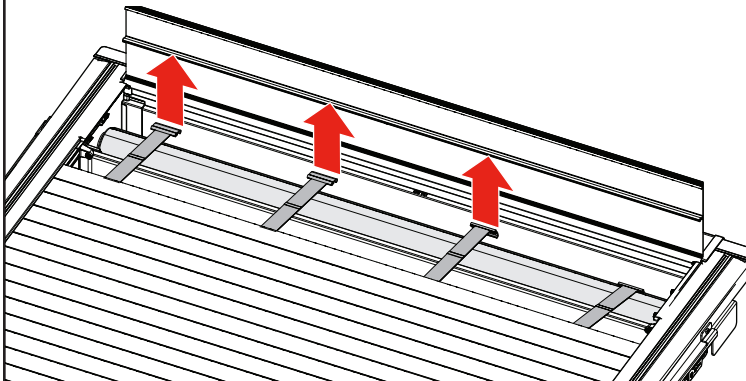

While making sure you don't let go, turn the spring axel 1 rotation against the tension to make opening stronger/faster, or with the tension to make it weaker/slower. Snap the lamella clips on to make sure it won't roll back. Make sure the band sits correctly on the clips.

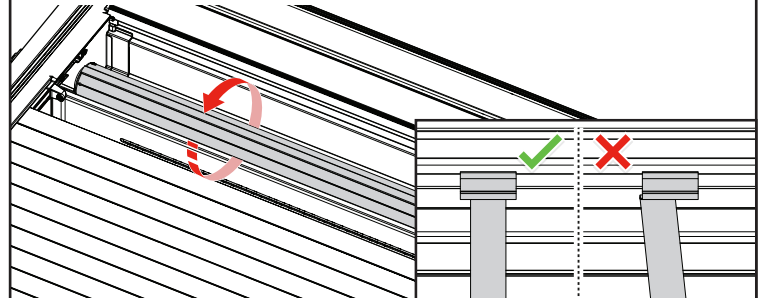

After clicking all lamella clips back on to the spring axel, test the cover to see if it feels better when rolling it back. Otherwise mount the rear corners back on and tighten the screws with 1.75 ft-lbs torque.

LIMITED WARRANTY

WARRANTY COVERAGE

This truck bed cover is warranted against defects in materials or workmanship as follows. This warranty is void if the product has been damaged in an accident, or due to neglect, unforeseeable use, improper installation, improper servicing, or other cause not arising out of defects in material or workmanship.

REALFLUSH - The truck bed cover carries a limited warranty for **five (5) years** from the original date of purchase, subject to the terms below.

WARRANTY IS NOT TRANSFERABLE

The warranty is to the initial owner purchasing the truck bed cover and it is not transferrable to a subsequent end user. Proof of purchase may be required to enforce these warranty rights.

WARRANTY CONDITIONS

Failure to follow care and use instructions will void the warranty.

- Clean with mild automotive soap and water only.
- Cover must be secured at all points when vehicle is in motion.
- Check all clamps and retention mechanisms for tightness after a week of driving following installation (or re-installation) of the cover and periodically thereafter.
- Before opening, the cover must be free of all foreign materials including snow and ice.
- Do NOT tow your vehicle from the rear with the cover on your vehicle. If towing from the rear is required, the cover **MUST** be removed from the vehicle and properly stored.

WARRANTY PERFORMANCE

If all warranty conditions are met, a defective truck bed cover or hardware component will either be repaired or replaced (at our option). We reserve the right, for any warranty, to substitute a newer model or bed cover having similar form and function, to offer a warranty discount on an entire replacement system, and/or provide remedies other than those mentioned in this document.

WARRANTY RETURN

A Return Material Authorization number must be obtained from our Customer Service Department prior to returning any product. We may require the original item to be returned postage prepaid for final determination. Shipping charges will apply for any repair or replacement. Other than postage or shipping charges, no charge will be made for repair or replacement under this warranty.

This warranty gives you specific legal rights. As an owner, you may also have additional rights and remedies under the laws of your state.

WARRANTY REGISTRATION

Warranty registration must be on file and/or proof of original purchase (detailed and dated receipt) required for warranty to be effective.

<https://realtruck.com/warranty-registration/>

**REGISTER
YOUR
WARRANTY
ONLINE**

