



INSTALLATION INSTRUCTIONS FOR MOUNTING

LUVERNE GRILL GUARDS WITH THE FOLLOWING MODEL NOS.:
330717/330718 AND 340717/340718 ON:

2007 AND NEWER 2500HD & 3500 CHEVROLET SILVERADO
2007 AND NEWER 2500HD & 3500 GMC SIERRA

1. READ THE INSTRUCTIONS COMPLETELY AND CHECK TO MAKE SURE THAT ALL OF THE REQUIRED PARTS ARE ON HAND BEFORE STARTING THE INSTALLATION. THE CARTON SHOULD CONTAIN:

- (1) OUTER RING PACKAGE
 - (1) OUTER RING ASSEMBLY
- (1) UPRIGHT/BRACKET PACKAGE:
 - (1) ASSEMBLED UPRIGHT, RH
 - (1) ASSEMBLED UPRIGHT, LH
 - (1) MOUNTING BRACKET, RH
 - (1) MOUNTING BRACKET, LH
 - (1) FASTENER PACKAGE
 - (1) CUSTOMER SERVICE PACKAGE

REFER TO FIGS. 1, 2, 3 & 4 FOR GUARD ASSEMBLY INSTRUCTIONS 2-11

2. LOOSEN AND REMOVE THE TWO BOLTS AND NUT THAT HOLD THE TOW HOOKS TO THE END OF THE FRAME. REMOVE THE TOW HOOKS.
3. INSTALL THE RIGHT HAND MOUNTING BRACKET (ITEM #4) INTO THE END OF THE FRAME. (NOTE: WHEN INSTALLING THE BRACKETS ON A CHEVROLET, BEND THE PLASTIC TAB IN THE AIR DAM TO THE INSIDE WHILE INSERTING THE BRACKET OR TRIM OFF THE TOP AND BOTTOM TABS EVEN WITH THE OUTSIDE HOLES, WITH A UTILITY KNIFE. SEE FIG. 3 ON PAGE 5. WHEN INSTALLING ON A GMC IT WILL BE NECESSARY TO NOTCH OUT THE PLASTIC WHERE THE BRACKETS COME THROUGH. SEE FIG. 4 ON PAGE 5.) FASTEN WITH THE 1/2"-13 X 1-1/2" BOLTS (ITEM #10), 1/2"-13 X 4-1/2" HEX BOLT (ITEM #9), 1/2" LOCK WASHERS (ITEM #16), 2.00 X .509 X .179 FLAT WASHER (ITEM #19) AND THE 1/2"-13 SERRATED FLANGE NUT (ITEM #13). LEAVE LOOSE AT THIS TIME.
4. REPEAT STEP #3 ON THE LEFT SIDE.
5. INSTALL THE RIGHT HAND UPRIGHT (ITEM #2) (NOTE: THE SQUARE HOLES ARE TO THE OUTSIDE.) ON THE RIGHT HAND MOUNTING BRACKET (ITEM #4) (NOTE: USE THE BOTTOM HOLES IN THE MOUNTING BRACKETS FOR CHEVROLET SILVERADO AND THE TOP HOLES FOR THE GMC SIERRA.) AND FASTEN WITH THE 1/2"-13 X 3" CARRIAGE BOLTS (ITEM #8), 1/2" SAE FLAT WASHERS (ITEM #18), AND THE 1/2"-13 CAP NUTS (ITEM #14). INSTALL ONLY THE LOWER BOLT AND ALLOW THE UPRIGHT TO TILT OUT. LEAVE LOOSE AT THIS TIME. YOU WILL NEED THE CLEARANCE TO GET THE RING INSTALLED.
6. REPEAT STEP #5 ON THE LEFT SIDE.



1200 E. Birch St.

Brandon, SD 57005

REVISED 31OCT11 LVL C
REVISED 31MAR11 LVL B
REVISED 17SEP07 LVL A
202391 SHEET 1 OF 5 09MAR07

7. LOWER THE CENTER RING ASSEMBLY (ITEM #1) DOWN BEHIND THE UPRIGHTS AND INSTALL IN THE SLOTS OF THE UPRIGHTS AS SHOWN IN FIG. 1 & 2. TILT THE RING AND THE UPRIGHTS TOWARD THE VEHICLE AND INSTALL THE TOP UPRIGHT BOLTS, WASHERS AND NUTS. MAKE SURE THE UPRIGHTS ARE CENTERED AND PARALLEL WITH THE BARS IN THE RING AND FASTEN WITH 7/16"-14 X 1-1/4" HEX BOLTS (ITEM #11) AND 7/16" FLAT WASHERS (ITEM #18) INTO THE 7/16"-14 CAPTIVE NUTS (ITEM #15) IN THE UPRIGHT MOUNTING PLATES. TIGHTEN TO 54 FOOT-POUNDS OF TORQUE.
8. CHECK THAT THE GRILL GUARD IS CENTERED ON THE GRILLE AND THE REAR OF THE UPRIGHT CUTOUT IS APPROXIMATELY 1/2"-3/4" AWAY FROM THE FACE OF THE BUMPER.
9. TIGHTEN THE 1/2" CAP NUTS (ITEM #14) ON THE 1/2"-13 X 3" CARRIAGE BOLTS (ITEM #8), FASTENING THE MOUNTING BRACKETS TO UPRIGHTS, TO 75 FOOT-POUNDS OF TORQUE.
10. TIGHTEN THE 1/2"-13 X 4-1/2" HORIZONTAL BOLTS (ITEM #9) AND THE BOTTOM 1/2"-13 X 1-1/2" BOLTS (ITEM #10), THAT FASTEN THE MOUNTING BRACKETS TO THE FRAME, TO 75 FOOT-POUNDS OF TORQUE.
11. INSTALL THE RIGHT AND LEFT UPRIGHT END CAPS (ITEMS #22 & #23) WITH THE 1/4"-20 X 3/8" BUTTON HEAD SCREWS (ITEM #21).

SERVICE PARTS LIST

ITEM	PART NO.	QTY	DESCRIPTION
1	202339	1	RING WELDMENT - CHROME
1	202344	1	RING WELDMENT - BLACK
2	202384	1	UPRIGHT WELDMENT - CHROME, RH
2	202392	1	UPRIGHT WELDMENT - BLACK, RH
3	202385	1	UPRIGHT WELDMENT - CHROME, LH
3	202393	1	UPRIGHT WELDMENT - BLACK, LH
4	202377	1	MOUNTING BRACKET - RH
5	202378	1	MOUNTING BRACKET - LH
6	201122	4	TAPPING BAR - 13.000"
7	107416	2	RUBBER EXTRUSION - 31.500
8	107231	4	ROUND HEAD BOLT - 1/2"-13 X 3", SST
9	100107	2	HEX HEAD SCREW - 1/2"-13 X 4-1/2", ZP
10	100088	4	HEX HEAD SCREW-1/2"-13 x 1-1/2", ZP
11	105939	4	HEX HEAD SCREW-7/16"-14 x 1-1/4", SST
12	103715	12	SELF TAPPING SCREW - 1/4"-20 X 5/8"
13	100123	2	SERRATED FLANGE NUT - 1/2"-13
14	104994	4	HEX CAP NUT - 1/2"-13, SST
15	100083	4	NUT CAPTIVE - 7/16"-14, BLK
16	100121	4	LOCK WASHER - 1/2", ZP
17	104995	4	FLAT WASHER - SAE, 1/2", SST
18	103286	4	FLAT WASHER - 7/16", SST
19	105909	2	FLAT WASHER - 2.00 X .509 X .179, ZP
20	105286	2	BUTTON HEAD SCREW - 1/4"-12 X 3/8", BLACK
21	201818	1	UPRIGHT END CAP - RH
22	201819	1	UPRIGHT END CAP - LH
23	105303	2	DECAL - MATTE BLACK, 1" X 10"
24	107383	4	NUT CAPTIVE - 1/2"-13, BLK
25	100252	1	DECAL - LOGO, 1 X 3



(A LUVERNE Company)

1200 E. Birch St.

Brandon, SD 57005

REVISED 31OCT11 LVL C
 REVISED 31MAR11 LVL B
 REVISED 17SEP07 LVL A
 202391 SHEET 2 OF 5 09MAR07

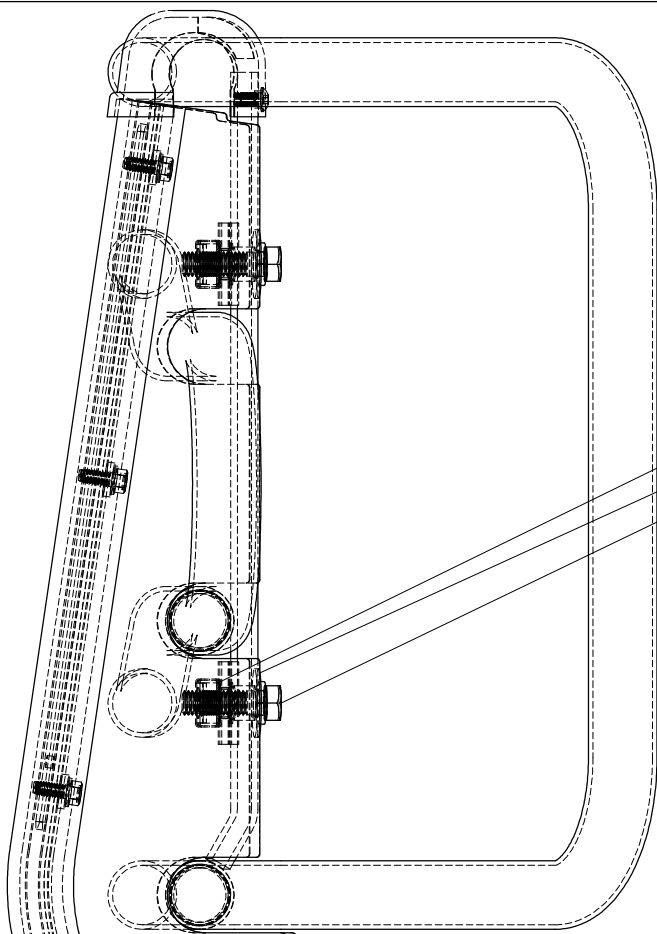

- 7/16" CAPTIVE NUT
- 7/16" FLAT WASHER, SST
- 7/16-14 X 1-1/4" HEX BOLT, SST

fig.1

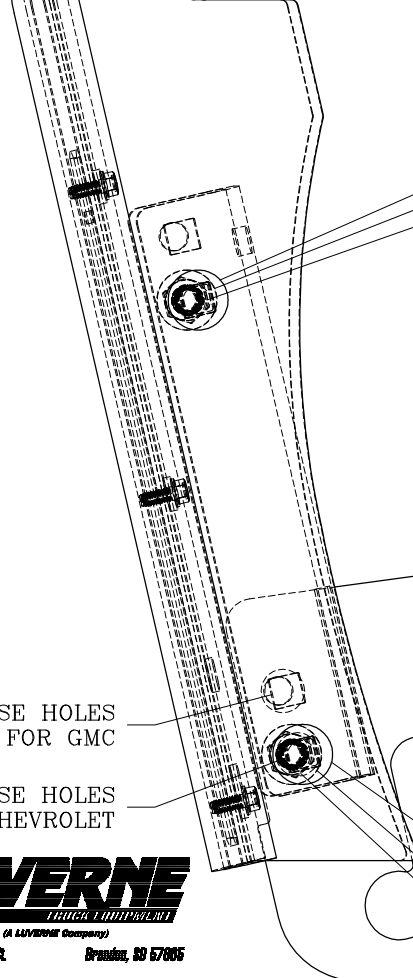

- 1/2"-13 X 3" CARR BOLT, SST
- 1/2" SAE FLAT WASHER, SST
- 1/2"-13 CAP NUT, SST

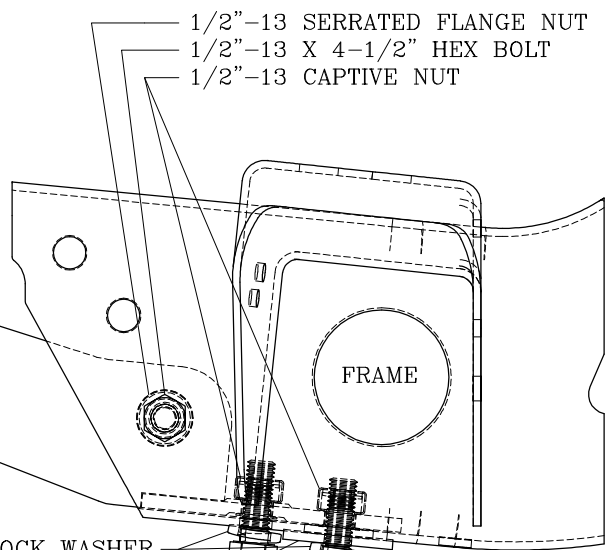

- 1/2"-13 SERRATED FLANGE NUT
- 1/2"-13 X 4-1/2" HEX BOLT
- 1/2"-13 CAPTIVE NUT

MOUNTING BRACKET

FRAME

THESE HOLES FOR GMC

THESE HOLES FOR CHEVROLET

1/2" LOCK WASHER

- 1/2"-13 X 3" CARR BOLT, SST
- 1/2" SAE FLAT WASHER, SST
- 1/2"-13 CAP NUT, SST
- 2" X .509 X .179 FLAT WASHER
- 1/2"-13 X 1-1/2" HEX BOLT



1200 E. Birch St. Brandon, SD 57805

REVISED 31OCT11 LVL C
 REVISED 31MAR11 LVL B
 REVISED 17SEP07 LVL A
 202391 SHEET 3 OF 5 09MAR07

SERVICE PARTS LIST

MODEL NO. - 330717/330718
 MODEL NO. - 340717/340718

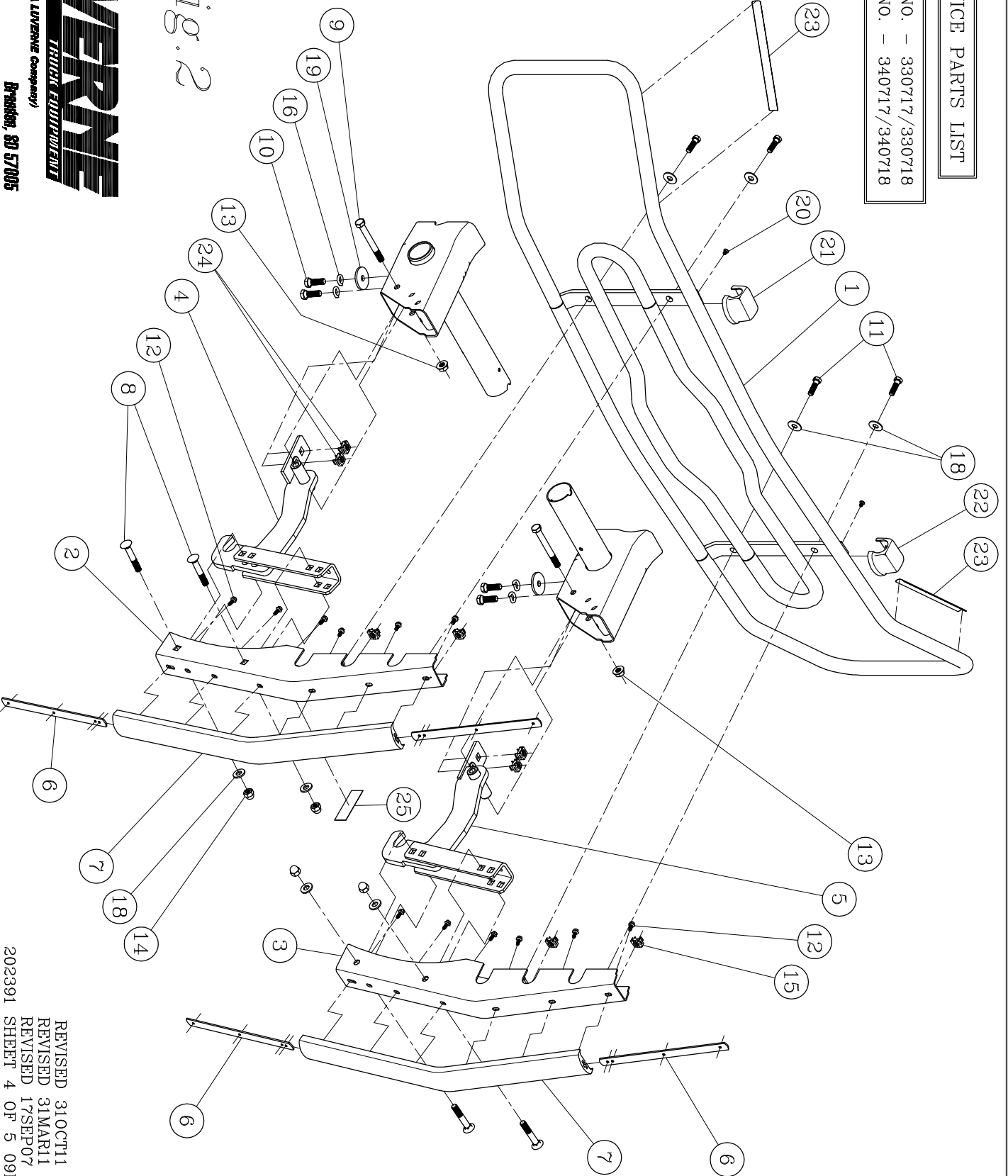

fig. 2



(A LIVERNE Company)

1200 E. Birch St.

Deerfield, SD 57005

REVISED 31OCT11 LVL. C
 REVISED 31MAR11 LVL. B
 REVISED 17SEP07 LVL. A
 202391 SHEET 4 OF 5 09MAR07

CHEVROLET VALANCE NOTCH

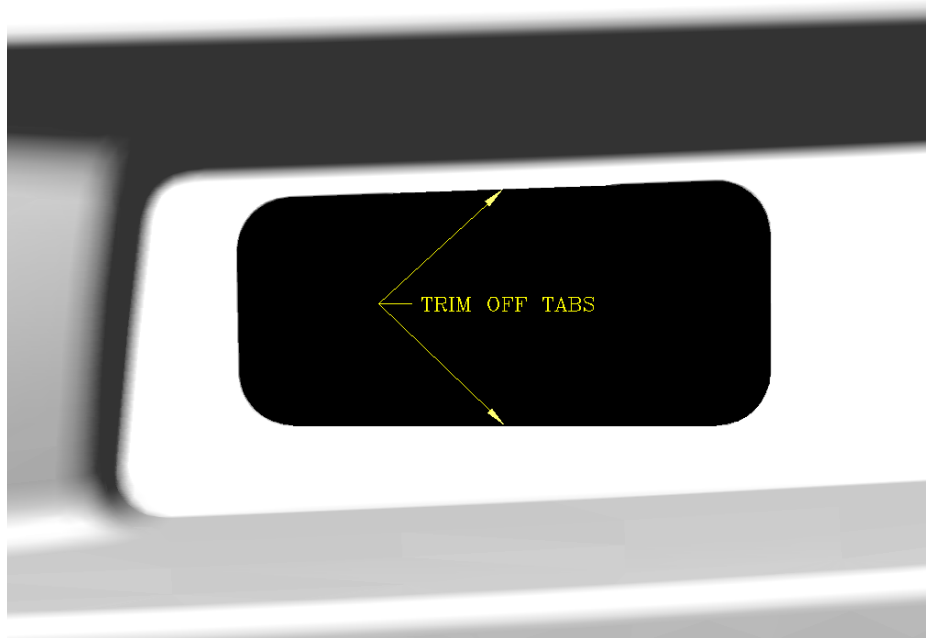

FIG. 3

NOTCH THE CHEVROLET LOWER VALANCE WITH A SHARP UTILITY KNIFE TO THE DIMENSIONS SHOWN IN FIG.3

GMC VALANCE NOTCH

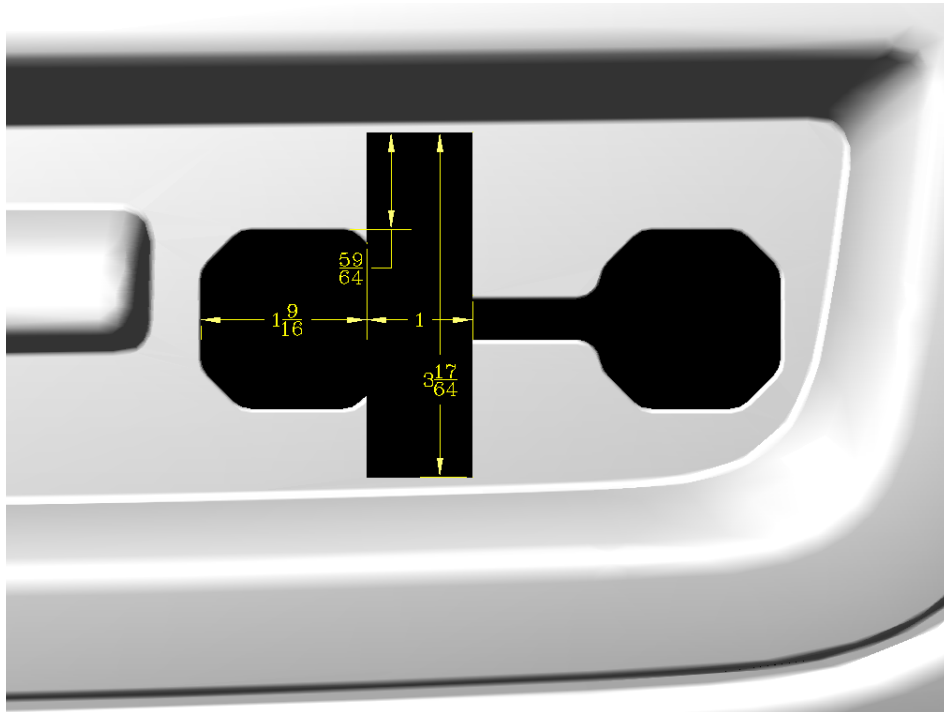

FIG.4

NOTCH THE GMC LOWER VALANCE WITH A SHARP UTILITY KNIFE TO THE DIMENSIONS SHOWN IN FIG.4

REVISED 31OCT11 LVL C
REVISED 31MAR11 LVL B
REVISED 17SEP07 LVL A
202391 SHEET 5 OF 5 09MAR07