



I-SHEET PART NUMBER: INST-00239
 PART NUMBER: **NBD19CC-TX**
 PRODUCT: **NERF BOARD**
 APPLICATION: **19-24 RAM 1500 CC**

HWKT-09617X		QTY
BHCS-09591X	M6X16MM BUTTON HEAD CAP SCREW	24
FW-09601	M6 FLAT WASHER	24
BHCS-09603	M6 flanged nut	24
CARB-09609	3/8"-16X1" Gr 5 Steel Carriage Bolt 1000B BLACK ZINC	12
FLNT-00664	3/8-16 GRADE 8 STEEL FLANGE NUT, ZINKLAD 1000B	12

HWKT-00031X		QTY
M8-1.25 HEX FLANGED NUT		18
M8 FLAT WASHER		18

PARTS INCLUDED	QTY
Driver Side Running Board	1
Passenger Side Running Board	1
Rocker panel brackets	6
Step Plate	4



Step 1: Identify Driver Side Nerf board.

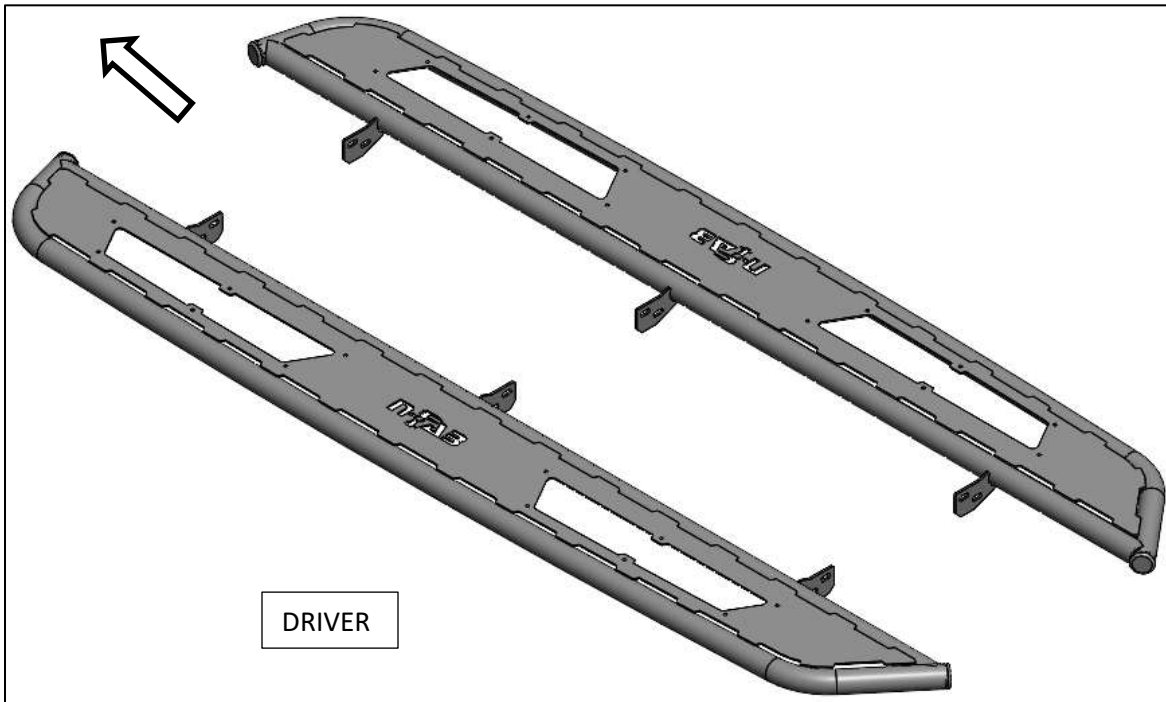

Step 2: Install the supplied step plate (x2) to each Running Board using the M6x20mm button head bolts, M6 nuts and M6 flat washer.

**** DO NOT OVER TIGHTEN ****

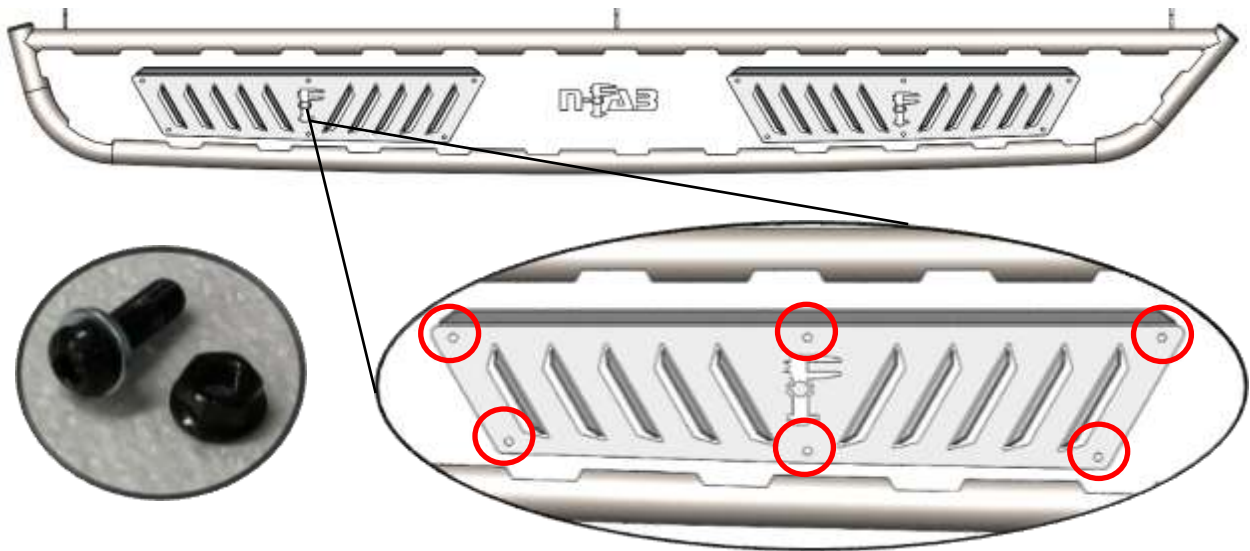

Step 3: Install the supplied rocker panel brackets (x6) to the attachment points located on the backside of the main tube (Driver/Passg) using the supplied 3/8" x 1" carriage bolts and 3/8" flanged nuts. Leave finger tight for now. ***** NOTE: Mounting bracket will mount forward on the tube attachment with the threaded part of the bolt facing towards rear of vehicle**

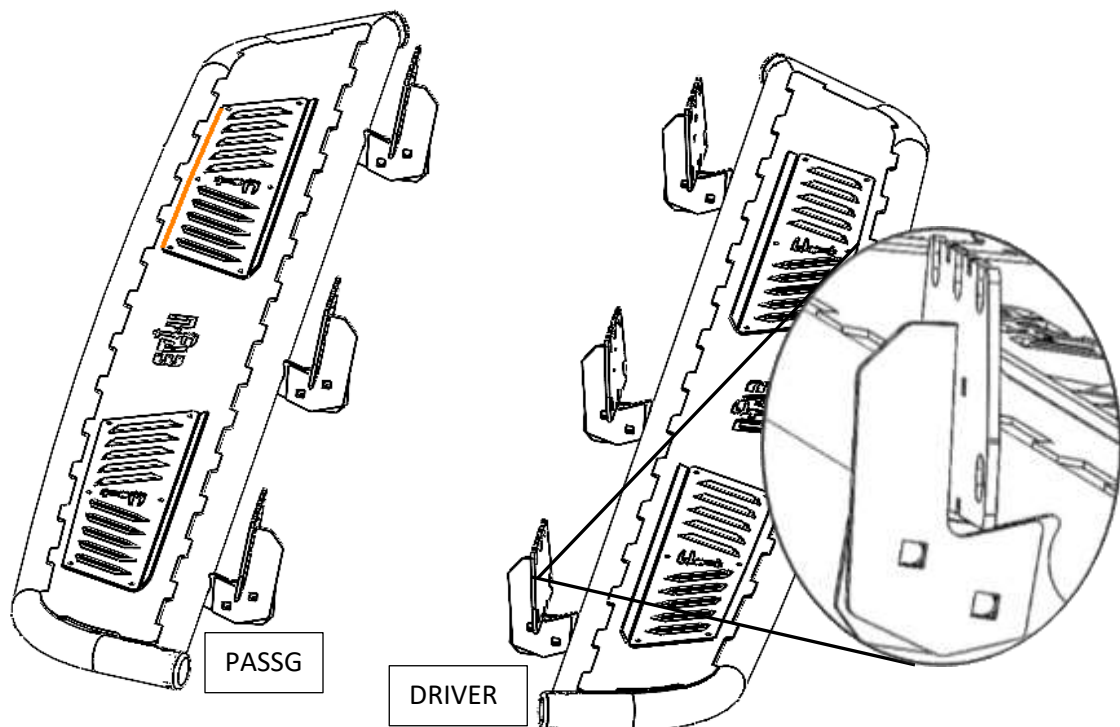



I-SHEET PART NUMBER: INST-00239
PART NUMBER: **NBD19CC-TX**
PRODUCT: **NERF BOARD**
APPLICATION: **19-24 RAM 1500 CC**

Step 4: On the inside rocker panel there will be three-attachment point consisting of three 8mm studs coming out from the panel. These studs may be covered in paint and will need to be cleaned before the installation.



Step 5: An additional person is recommended for this step. Carefully install the step assembly to the three factory attachment points using the provided M8 flanged hex nuts. Leave finger tight for now.



Step 6: There will be ½" of adjustment in the (x3) mounting bracket. Adjust to desired position and tighten to (20 ft./lbs). Then tighten body mount brackets to (17-20 ft./lbs)



Step 7: Repeat steps 4-6 for the passenger side.