



# INSTALLATION INSTRUCTIONS

## HAVOC HS2

### NERF BAR WITH STEP

### HPG-56-40004

2018-CURRENT JEEP WRANGLER JLU, 4-DOOR

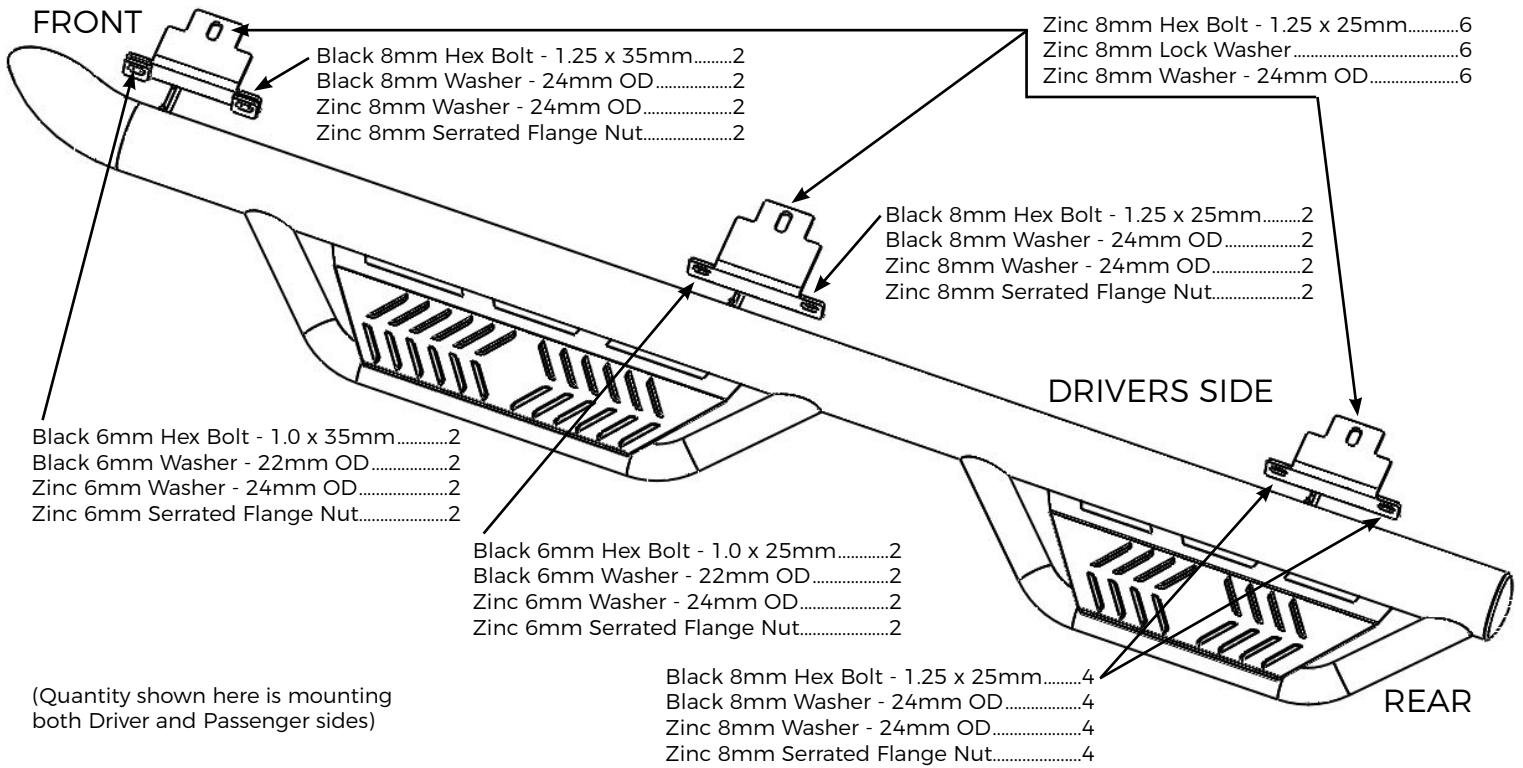

(Quantity shown here is mounting both Driver and Passenger sides)

#### STEP 1:

Identify the driver and passenger bars. The front of the tube has a bend and the rear has a cap.



#### STEP 2:

Carefully place HS2 step into place. Best to have a assistant to lift and hold step in place.

Use Zinc 8mm bolt, washers and begin hand tightening all upper mountings (Note bolt marked "A" in photo).

Do Not fully tighten but thread enough to pull step to the body of the Jeep.

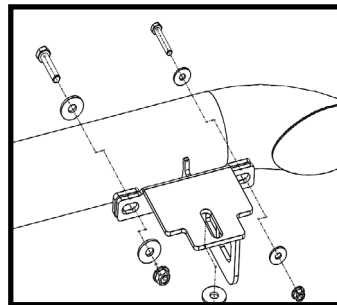

#### STEP 3:

Install hardware in the pinch weld of the Jeep. In each mounting the bolt and flat washer are black on the outside of the pinch weld, where it's visible. The rest of the hardware is zinc, where it's not visible. Use the hardware list above to know each bolt location.



#### STEP 4:

**Avoid using power or air tools.** Tighten upper mountings first then pinch weld bolts. Checking that the step is level. Tighten to 20ft lbs torque to secure the step to the Jeep. Repeat the same procedure to the other side.