



INSTALLATION INSTRUCTIONS

HAVOC HST

RUNNING BOARDS

HPG-007232

2019-CURRENT RAM 1500 CREW CAB (EXCLUDES CLASSIC)

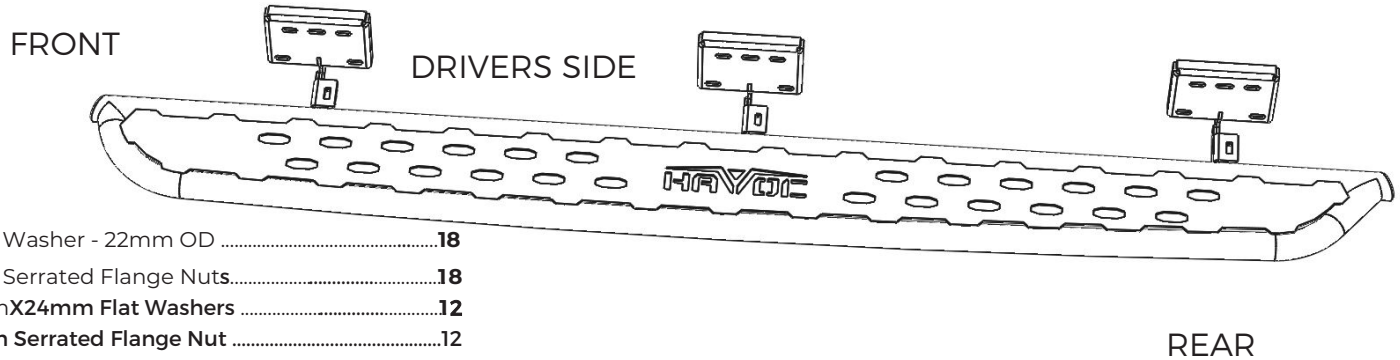

Hardware:

Zinc 8mm Washer - 22mm OD	18
Zinc 8mm Serrated Flange Nuts.....	18
Black 8mmX24mm Flat Washers	12
Black 8mm Serrated Flange Nut	12
Black 8mm-1.25 X 20mm Carriage Bolts.....	12

Attention: Do Not use power or air tools to install or tighten hardware.

STEP 1:

Each mounting location consist of 3 Factory installed mounting studs. Shown here. If your vehicle was not equipped with factory installed running boards then you may need to carefully clean (chase) the threads of each stud with the proper die.



STEP 2:

Identify the driver and passenger bars. The front of the step is More Rounded to the front end of the Step. Use illustration above as a visual reference to determine each side.

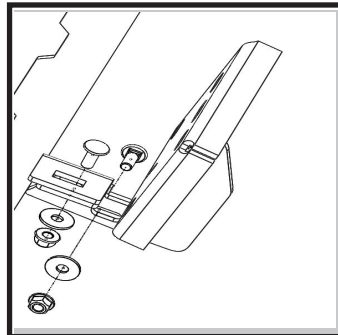

STEP 3:

The HST is a Bolt together bracket and allows you to either install your bracket to the vehicle first, or bolt them to the running board then proceed to bolt to the Vehicle. Use the **Black Carriage Bolts, Flat Washers & Serrated Flange Nuts** To secure brackets to Running Board as shown above.



STEP 4:

With the proper Hardware, Install the M8 x 22mm Flat Washer and thread on the M8 Serrated Flange Nut leaving the nut loose. Do not fully tighten any hardware until all hardware has been installed for that side.

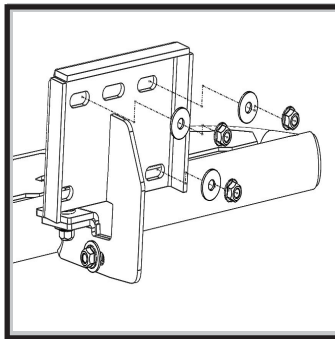

STEP 5:

Once all hardware has been installed, Adjust the final resting position of the running board & begin tightening nuts & bolts in a alternating pattern. **Avoid using power or air tools.** Tighten to approx. 18 ft/lbs of torque to secure boards to the brackets and the brackets to the truck.



STEP 6:

Repeat the same process for the Opposite Side of the vehicle.

