



INSTALLATION INSTRUCTIONS

HAVOC HS3

NERF BAR WITH STEP

HPG-003035

1999-2016 FORD SUPER DUTY CREW CAB 6'9" BED

FRONT

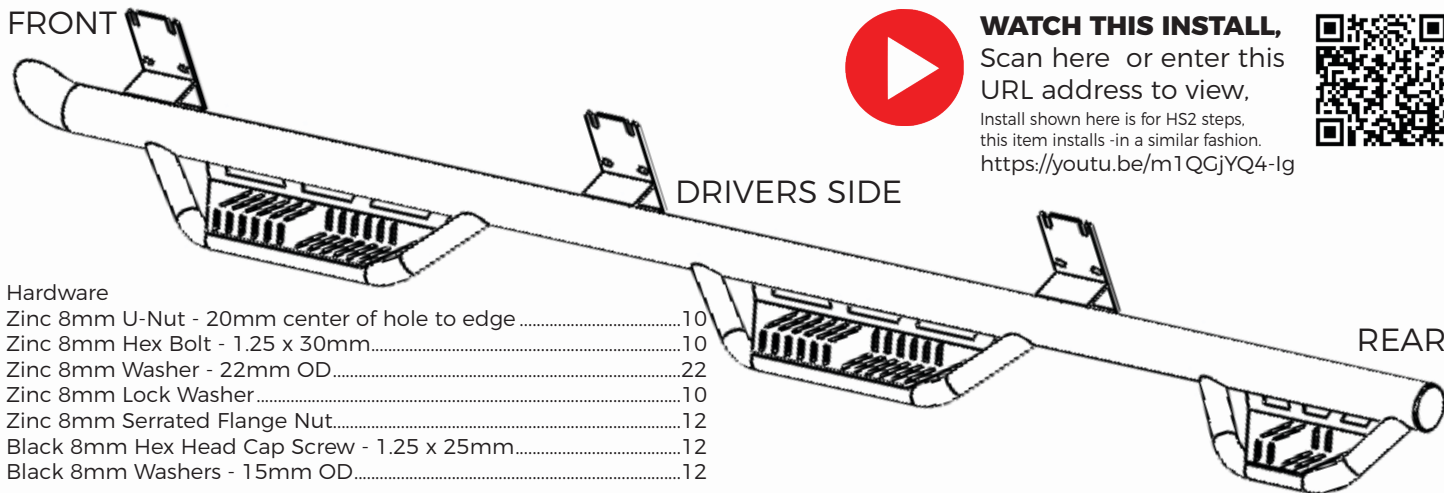

WATCH THIS INSTALL,
Scan here or enter this URL address to view,
Install shown here is for HS2 steps,
this item installs in a similar fashion.
<https://youtu.be/m1QGjYQ4-Ig>



Hardware

Zinc 8mm U-Nut - 20mm center of hole to edge.....	10
Zinc 8mm Hex Bolt - 1.25 x 30mm.....	10
Zinc 8mm Washer - 22mm OD.....	22
Zinc 8mm Lock Washer.....	10
Zinc 8mm Serrated Flange Nut.....	12
Black 8mm Hex Head Cap Screw - 1.25 x 25mm.....	12
Black 8mm Washers - 15mm OD.....	12

STEP 1:
Identify the driver and passenger bars. The rear side is the smallest step on the bar. This goes towards the rear tire.



STEP 2:
Each mounting bracket consist of 4 mounting holes. The upper open holes mounts to the body of the truck and the lower holes to the pinch weld.

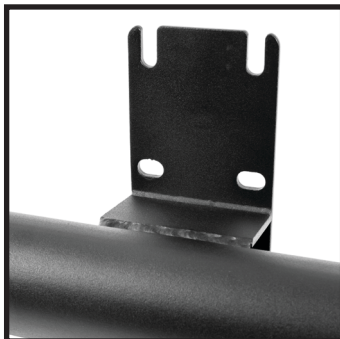

STEP 3:
Insert spring loaded U nuts to the body of the truck. Use two on center and rear mount location. The front mount only uses one U nut.

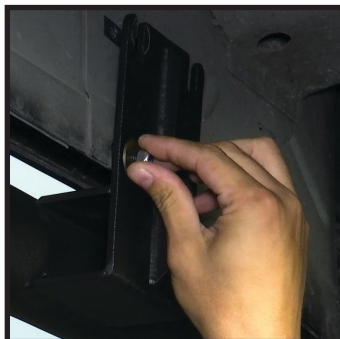

STEP 4:
Carefully place HS2 step into place. Insert black hex bolt (bolt head facing out) and black washer through pinch weld hole and secure with flange nut and zinc washer on back. Best to have a assistant to lift and hold board in place.

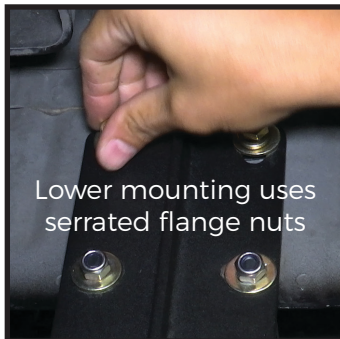

Lower mounting uses serrated flange nuts

STEP 5:
Use bolt, washer and lock washer, begin hand tightening upper mountings.



STEP 6:
Begin tightening nuts in a alternating pattern. **Avoid using power or air tools.** Tighten to 20ft lbs torque to secure the board to the truck. Repeat the same procedure to the other side.