



INSTALLATION INSTRUCTIONS

HAVOC HS2

NERF BAR WITH STEP

HPG-001302

2004-CURRENT NISSAN TITAN CREW CAB,
2016-CURRENT NISSAN TITAN XD CREW CAB

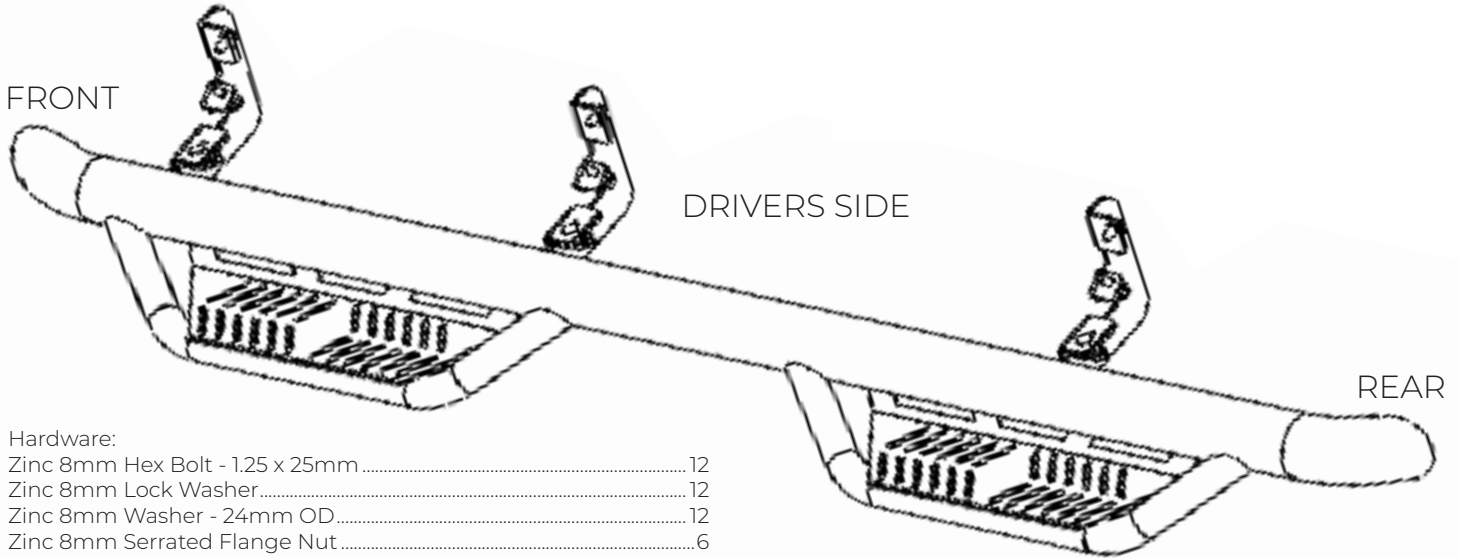

Hardware:

Zinc 8mm Hex Bolt - 1.25 x 25mm	12
Zinc 8mm Lock Washer.....	12
Zinc 8mm Washer - 24mm OD.....	12
Zinc 8mm Serrated Flange Nut.....	6
Black 8mm Carriage Bolt - 1.25 x 25mm.....	12
Black 8mm Washers - 22mm OD.....	12
Black 8mm Serrated Flange Nut.....	12

STEP 1:

Identify the driver and passenger bars. The center bracket is closer to the front of the truck.

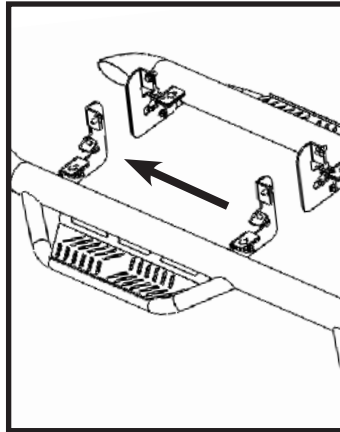

STEP 5:

Carefully place HS2 step on HS2 brackets. Insert the 2 black carriage bolts through the board bracket to the bracket attached to the truck. Place black washer and thread serrated nut to each carriage bolt.

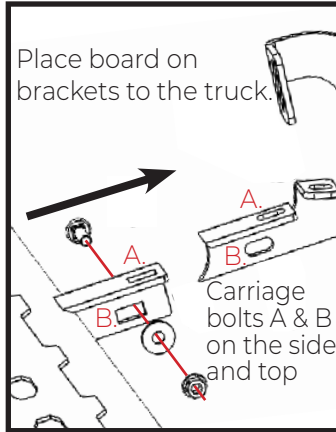

STEP 3:

Each bracket has two mounting points to the truck. The upper to the body and the lower to the pinch weld. First thread the bolt to the body to hold the bracket. Next thread the pinch weld and hand tighten snug. This will place the bracket in its correct position.

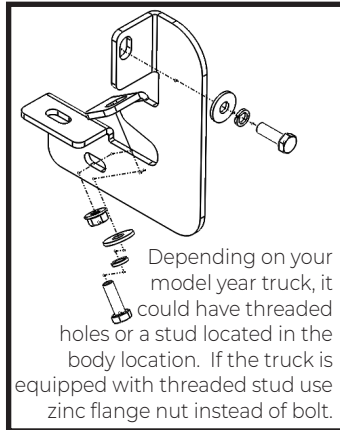

STEP 6:

Avoid using power or air tools. Tighten pinch weld mounts first then upper bolts. Checking that the board is level. Tighten to 20ft lbs torque to secure the board to the truck. Repeat the same procedure to the other side.

