

Installation Instructions

Road Defender Push Bumper Part # 5296

2018 - 2019 Ford F-150 Police Responder

Do not attempt to install this product on any vehicle other than the one listed above!

Parts List				
Item	QTY	Code	Description	Max Torque
1	1 pc	5296	Push Bumper Body	
2	1 Set	504334BA	Main brackets set	
3	2 pcs	52962AA	Auxiliary bracket	
4	4 pcs		1/2 x 1 1/2" hex head bolt Black	70 Lb. Ft.
5	8 pcs		1/2" flat washer Black	
6	4 pcs		1/2" lock washer Black	
7	4 pcs		1/2" hex nut Black	70 Lb. Ft.
8	4 pcs		1/2" flat washer Blue	
9	4 pcs		1/2" lock washer Blue	
10	4 pcs		1/2" hex nut Blue	70 Lb. Ft.
11	2 pcs		3/8 x 1 1/4" hex head bolt	30 Lb. Ft.
12	4 pcs		3/8" flat washer	
13	2 pcs		3/8" lock washer .	
14	2 pcs		3/8" nut	30 Lb. Ft.
15	4 pcs		1/2 x 1 1/2" tab bolts	70 Lb. Ft.
16	1 pcs		1/2" Bolt guide wire	

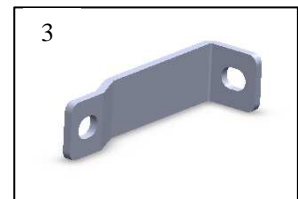
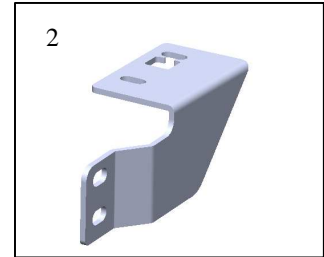

Tool Required:

21mm, 9/16" & 3/4" Socket
 9/16" & 3/4" Wrench
 Flat Screw Driver
 Ratchet & 5" Ratchet Extension
 Utility Knife
 Tape Rule

Approximated installation time: 60 min.

Read the installation instructions completely and verify that all of the parts listed are accounted for. If you have defective, missing or damaged parts or need assistance, please contact Go Rhino Products for fast, friendly customer service at: 1-888-427-4466 or email: warranty@gorhino.com

To maintain and care this product keep it clean and do not use abrasive cleaners or polish waxes. It is recommended to use only non-abrasive automotive wax such as pure carnauba to avoid scratches and rust.

1. If the vehicle has tow hooks remove the black rubber tow hook cover .
2. Remove the front bolt and loosen the rear bot. See Image 1. If vehicle does not have tow hooks follow to step 4.

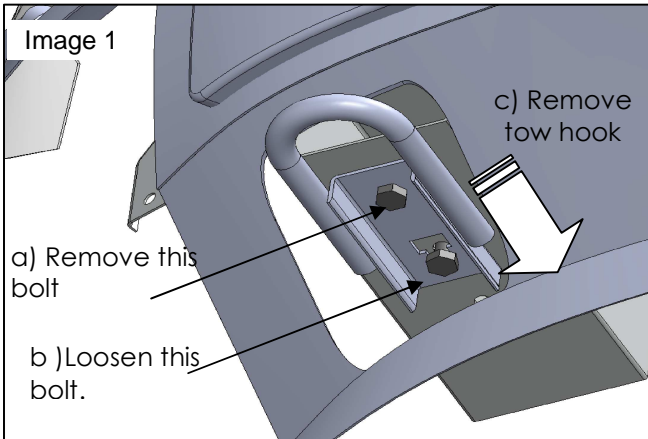

3. **Slide lower bracket between** the rear tow hook bolt and re-install the tow hook over the bracket. **Re-attached** using the factory bolts removed in step 2. **Image 2**. Leave loose. **Follow to step 8**.

4. If the vehicle **does not have** tow hooks, use the template, (printed at the end) as a guide to modify the lower valance. **NOTE:** Before proceeding with the valance modification, make sure that the supplied paper template has the dimensions clearly printed and check them out. **PROFESSIONAL INSTALLATION RECOMMENDED.**



5. Align paper template to the edges shown at **Photo 3**, mark area to cut out and proceed. Repeat for opposite side, review simmetry.

6. Once openings were made, place tab bolts into the frame holes as shown at **Image 4**. Use the wire guide to place tab bolts.

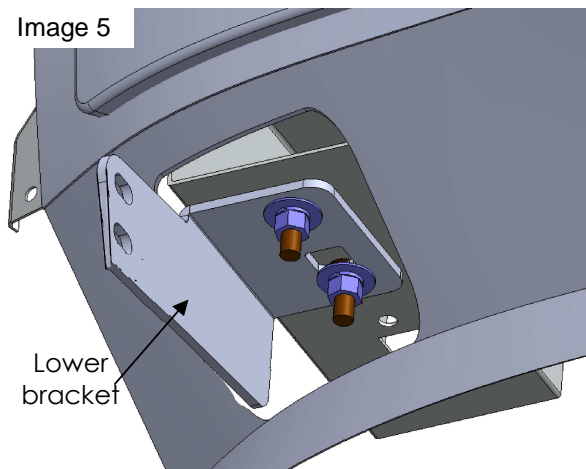
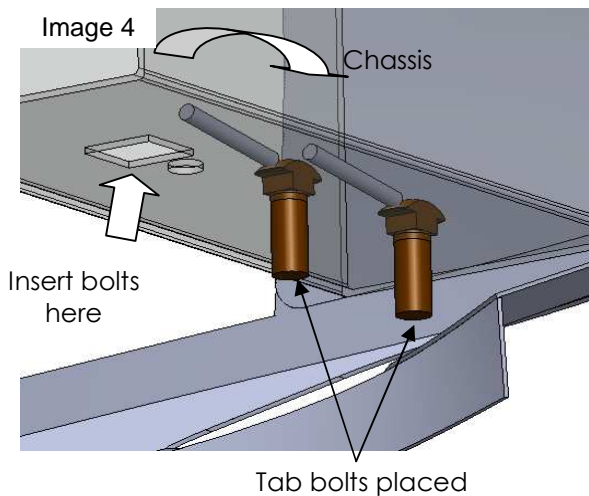

7. Place lower bracket on the bottom frame, fasten using 1/2" flat and lock washers and hex nuts. **Image 5**

8. Remove the plastic bumper cover (image 6) and locate the outer factory nut. Remove the nut and position the auxiliary bracket. Secure the auxiliary bracket using the factory nut removed. Image 7. Do not tighten.

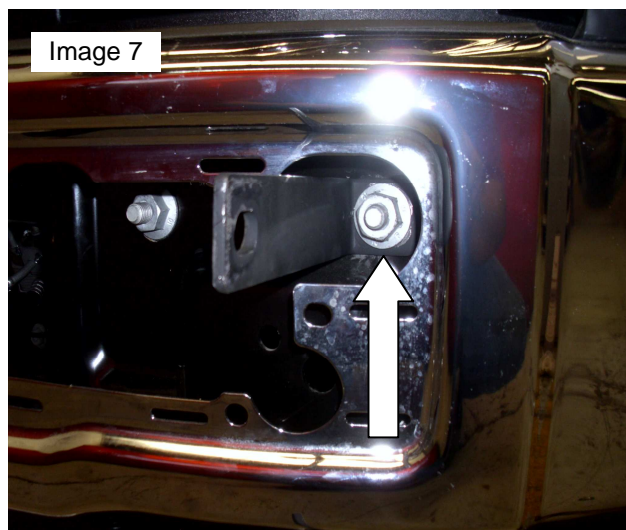
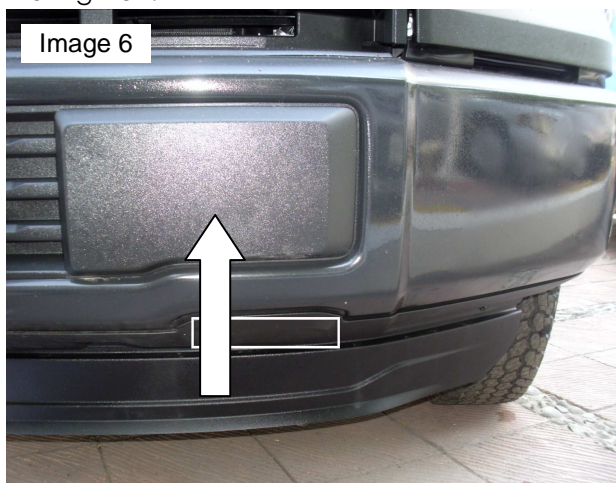

9. After installing the auxiliary bracket cut the plastic bumper cover to allow the auxiliary bracket pass through. Place the plastic cover but do not install yet. Image 8.

10 . Place Push Bumper over the brackets. Secure the lower brackets using (2) 1/2 x 1 1/2" hex bolts, (4) 1/2" flat washers and (2) 1/2" lock nuts. Secure to auxiliary bracket using (1) 3/8 x 1 1/4" hex bolt, (1) 3/8" flat washer and (1) 3/8" hex nut. Leave loose.

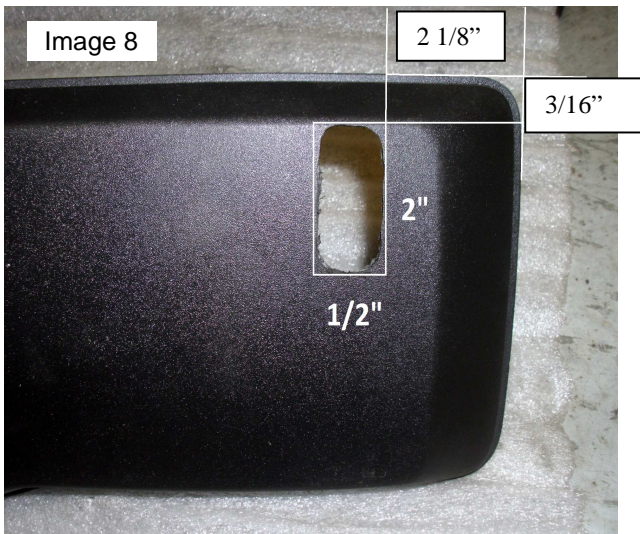

11. Align the Push Bumper with the front of the vehicle and tighten all bolts and nuts. Reinstall the plastic bumper cover.

12. Periodically it may need re-tighten the bolt



