

Installation Instructions

Road Defender Push Bumper #5077

2015 Dodge Charger Pursuit

Do not attempt to install this product on any vehicle other than the one listed above!

Parts List

Item	Qty.	Part #	Description	Item	Qty.	Part #	Description	Torque
1	1	50770AA	Push Bumper Assembly	5	4		M8 x 90mm Hex Bolt	16 Ft. Lbs
2	1	50770CB	Passenger Side Bracket	6	4		5/16" Flat Washer	
3	1	50770CB	Driver Side Bracket	7	4		5/16" Lock Washer	
4	4	G507582	Spacer Tube	8	8		3/8" x 1 1/4" Hex Bolt	30 Ft. Lbs
				9	16		3/8" Flat Washer	
				10	8		3/8" Lock Washer	
				11	8		3/8" Hex Nut	

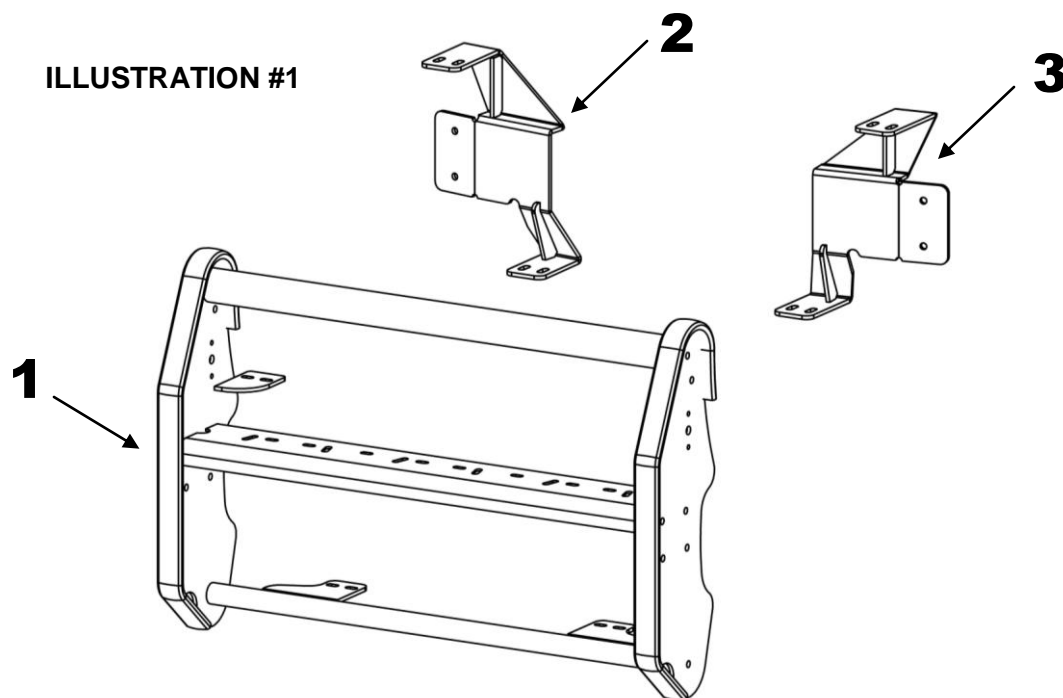

Tool Required:

7mm, 10mm, 13mm & 9/16" Sockets
 9/16" Wrench
 Pliers
 Slotted Blade Screw Driver
 Ratchet, Ratchet Extensions & Swivel Joint Adapter

Approximate installation time: 90 min

Read the installation instructions completely and verify that all of the parts listed are accounted for. If you have defective, missing or damaged parts or need assistance, please contact *Go Rhino Products* for fast, friendly customer service at: 1-888-427-4466 or email: warranty@gorhino.com

Front Bumper Fascia Removal

Step-1 Open the hood, unplug and remove the (12) plastic rivets (6) per side securing the bumper fascia support, and the (2) screws (1 per side) securing bumper fascia to the fender, (Photo 1).

Step-2 From underside of the vehicle, remove the (6) screws (3 per side) securing the bottom of the bumper fascia to the plastic splash pan, (Photo 2).

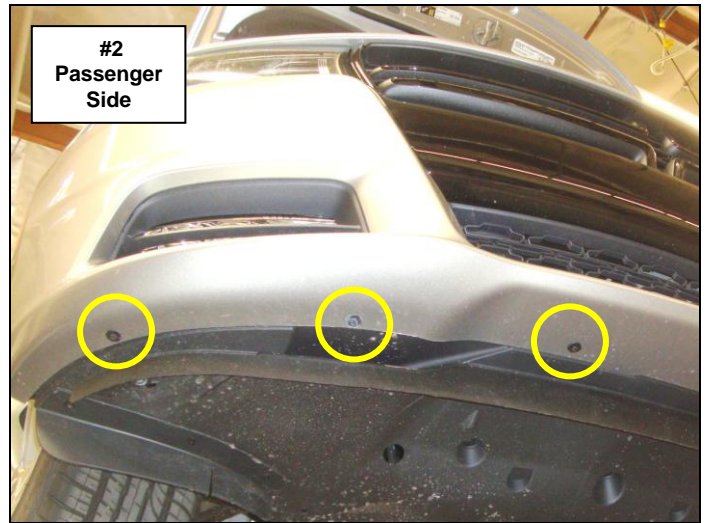
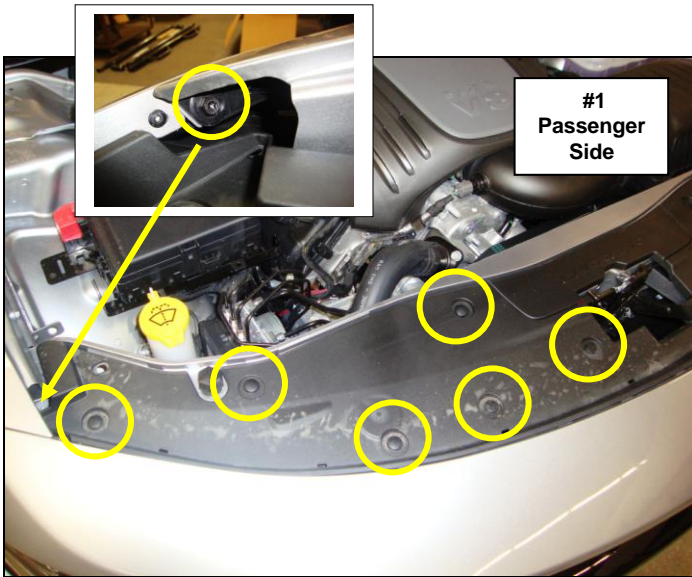

Step-3 Remove the (3) screws securing the brake cooling duct to the fender well, (Photo 3).

Step-4 Remove the (11) plastic rivets securing the front section of the fender well to the fender panel and bumper fascia, (Photo 4).

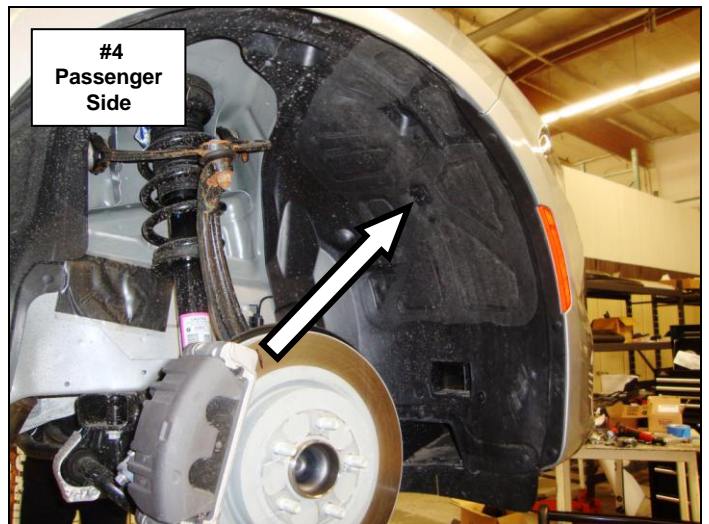
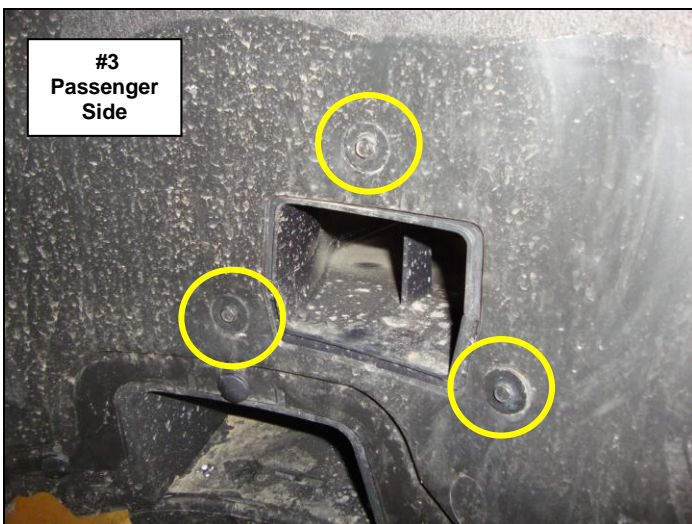

Step-5 Pull back the front section of the fender well and remove the (2) bolts securing the bumper fascia to the fender. Disconnect (unplug) the side marker light wiring and If equipped disconnect the fog light, (Photo 5 & 6). Repeat steps 3, 4 and 5 on the driver side of the vehicle.

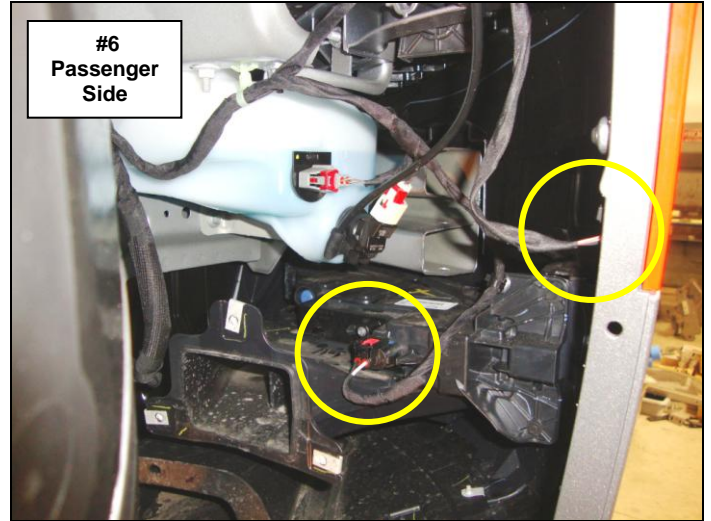
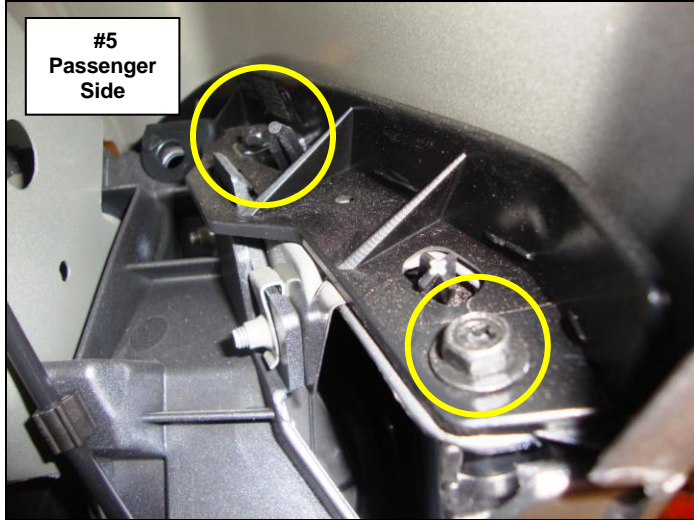

Step-6 With assistance pull out on the sides of the fascia and forward to remove it from the vehicle.

Step-7 Locate the holes in the bumper impact beam. Remove the bolts (2 per side) closest to the center of the vehicle, (Photo 7).

Push Bumper Installation

Step-8 Assemble (2) of the 8mm hex bolts, (2) 5/16" lock washers, (2) 5/16" flat washers and (2) spacer tubes onto the flange of the passenger side bracket, (Photo 8).

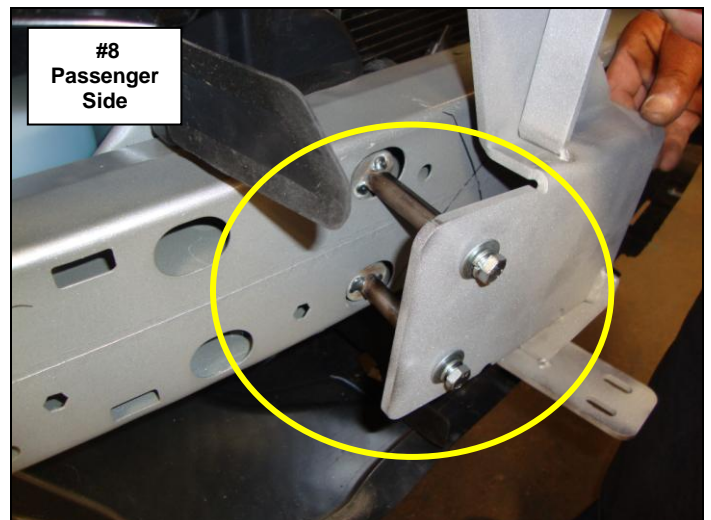
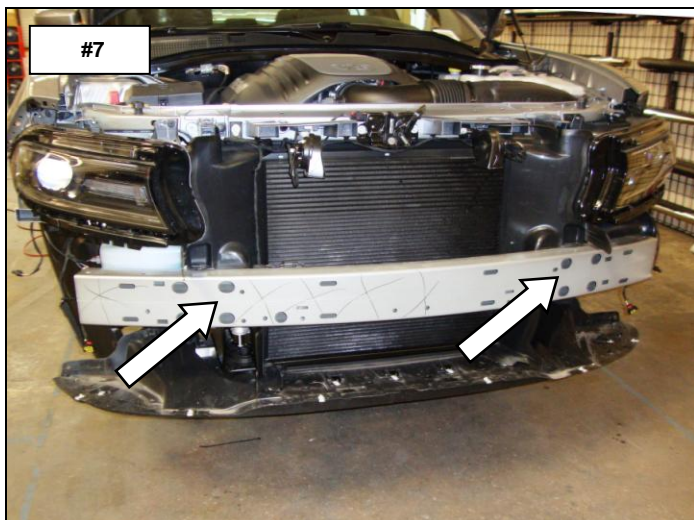

Step-9 Attach the bracket to the impact beam. Position the flange of the bracket approximately 11 1/2" from the end of the impact beam and tighten the bolts, (Photo 9 &10). Repeat steps 8 and 9 for the driver side bracket.

Note: To confirm the brackets are in the correct position, it is recommended to temporarily attach the push bumper to the brackets using the 3/8" bolts supplied

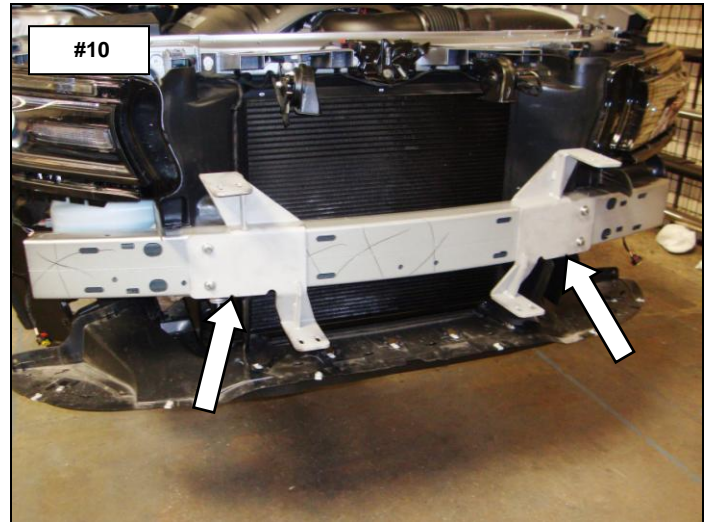

Step-10 The bumper insulator must be notched (top and bottom) to properly fit around the brackets, (Photo 11 &12). Remove the insulator from the bumper fascia. Position the insulator up to the bumper and mark the bracket locations. Notch the insulator and check fit by returning the insulator to the bumper until the proper fit is achieved. Re-install the bumper insulator in the bumper fascia.

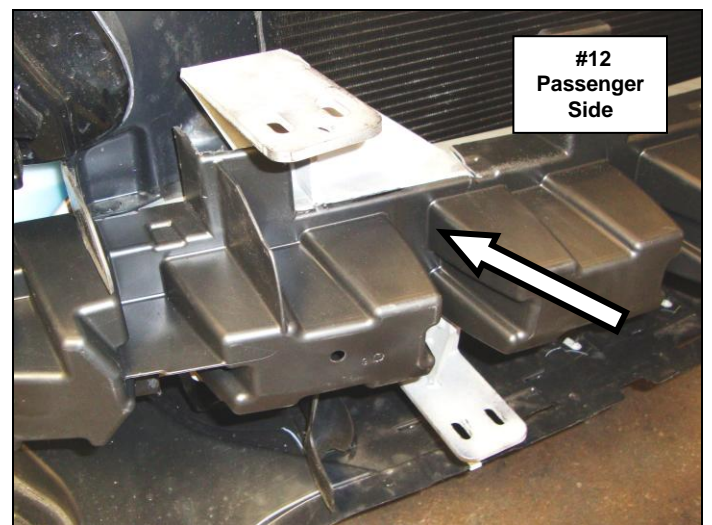
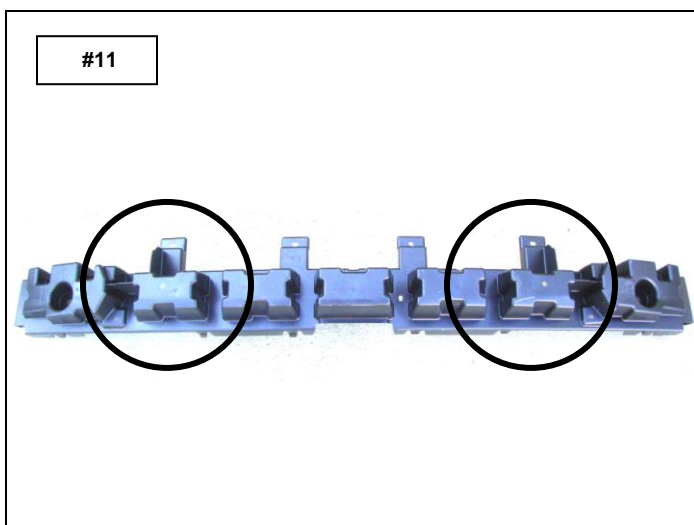

Step-11 Remove the Dodge emblem from the upper grille, (Photo 13).

Step-12 With assistance position the bumper fascia up to the vehicle, align the bumper fascia so the brackets protrude through the opening in the upper and lower grille and re-install the bumper fascia, (Photo 14).

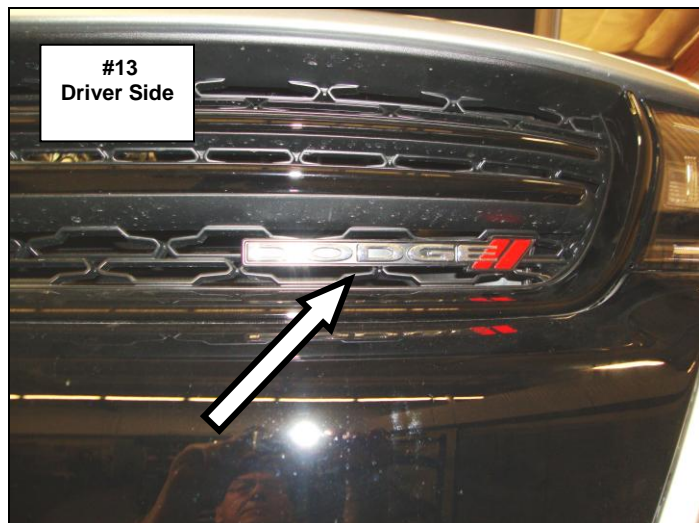

Step-13 Attach the push bumper to the brackets using the supplied 3/8" x 1 1/4" hex bolts, 3/8" flat washers, 3/8" lock washers and 3/8" hex nuts, (Photo 15).

Step-14 Align the push bumper with the vehicle and tighten all nuts and bolts.

