

Installation Instructions

Road Defender Push Bumper Part #5039

2013 Ford Taurus Police Interceptor

Do not attempt to install this product on any vehicle other than the one listed above!

Parts List

Item	Qty.	Part #	Description	Torque
1	16		3/8" x 1" Hex Bolt	30 Ft. Lbs.
2	4		3/8" x 1" Carriage Head Bolt	30 Ft. Lbs.
3	20		3/8" Lock Washer	
4	20		3/8" Hex Nut	30 Ft. Lbs.
5	2	378312	1/2" Bolt Plate	
6	2		1/2" Lock Washer	
7	2		1/2" Hex Nut	65 Ft. Lbs.
8	1	AST-TU68	Wire Bolt Guide	
9	1	5039	Push Bumper Assembly	
10	1	503921	Driver Side Main Bracket	
11	1	503922	Passenger Side Main Bracket	
12	2	503925	Main Bracket Spacer	
13	1	503911	Driver Side Clamp Bracket	
14	1	503912	Passenger Side Clamp Bracket	
15	1	503931	Driver Side Upper Extension Bracket	
16	1	503932	Passenger Side Upper Extension Bracket	
17	1	503951	Driver Side Lower Extension Bracket	
18	1	503952	Passenger Side Lower Extension Bracket	

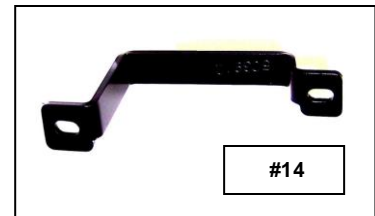

Tool Required:

5.5mm, 8mm, 10mm, 9/16" & 3/4" Socket
 9/16" Wrench
 Philips & Slotted Tip Screw Driver
 Ratchet & Ratchet Extension
 Jig Saw or Dremel Tool
 Tape Rule

Approximate installation time: 45 min

Read the installation instructions completely and verify that all of the parts listed are accounted for. If you have defective, missing or damaged parts or need assistance, please contact *Go Rhino Products* for fast, friendly customer service at: 1-888-427-4466 or email: warranty@gorhino.com

Front Bumper Fascia Removal

Step-1 Open the hood, locate and remove the (8) Phillips screws, (4) 10mm head screws and (2) plastic fasteners securing the radiator cover and bumper fascia to the radiator support. **Picture #1**

Remove the radiator cover from the vehicle.

Step-2 On each side, remove (1) Phillips screw, (2) 5.5mm head screws and (2) 10mm head screws attaching the fender liner to the fascia. **Picture #2**

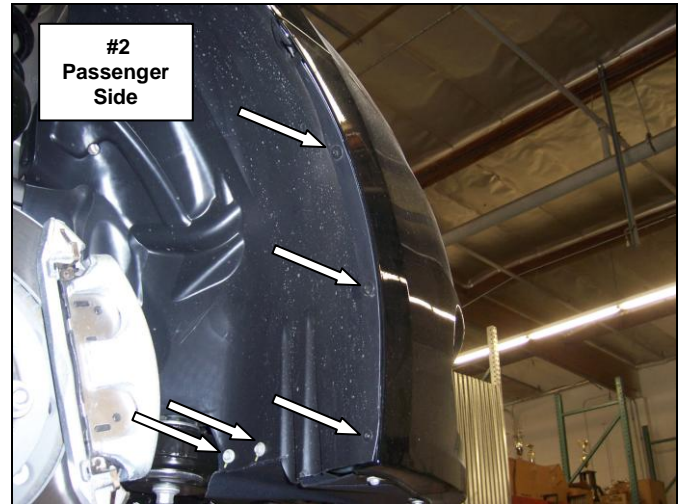
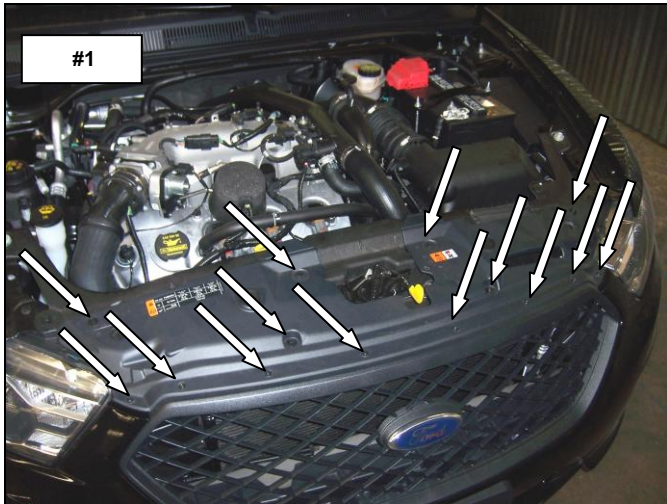

Step-3 Pull back the fender liner and remove the Phillips screw and plastic fastener attaching the fascia to the fender. **Picture #3**

Step-4 Remove the (4) 8mm head screws attaching the rear of the splash shield to the radiator support. **Picture #4**

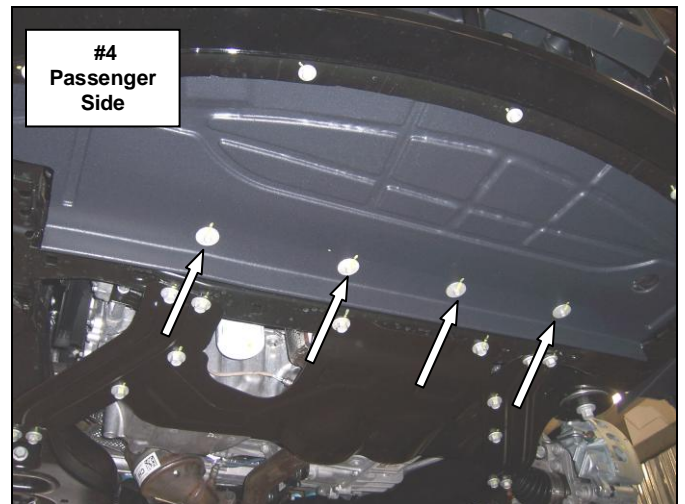

Step-5 With assistance pull out on the sides to release the corners of the bumper fascia and forward to remove it from the vehicle.

Push Bumper Installation

Step-1 Beginning with the passenger side, install (1) 1/2" bolt plate in the outer hole in the face of the steel impact beam using the supplied wire guide. **Picture #5**

Step-2 Position (1) spacer plate and the passenger side main bracket over the bolt plate, and secure the spacer plate and main bracket to the impact beam using (1) 1/2" lock washer and (1) 1/2" hex nut. Leave the nut loose for final adjustment. **Picture #6**

Repeat the above steps for the driver side.

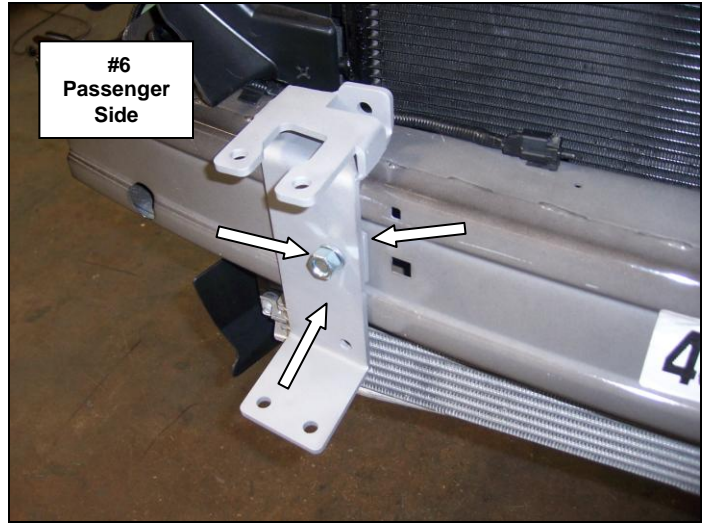
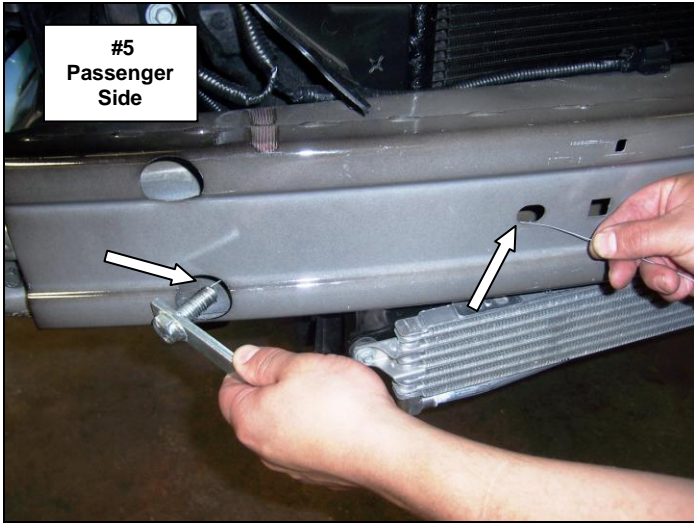

Step-3 Insert the top of the passenger side clamp bracket through the gap between the impact beam and auxiliary cooler, and then rotate the bracket into position. Slide the bracket to the left and align the holes in the clamp bracket with the main bracket. Secure the clamp bracket to the main bracket using (2) 3/8" x 1" carriage bolts, (2) 3/8" lock washers and (2) 3/8" hex nuts. **Picture #7 & #8** Leave the nuts and bolts loose for final adjustment.

Note: Position the wiring harness behind the clamp bracket.

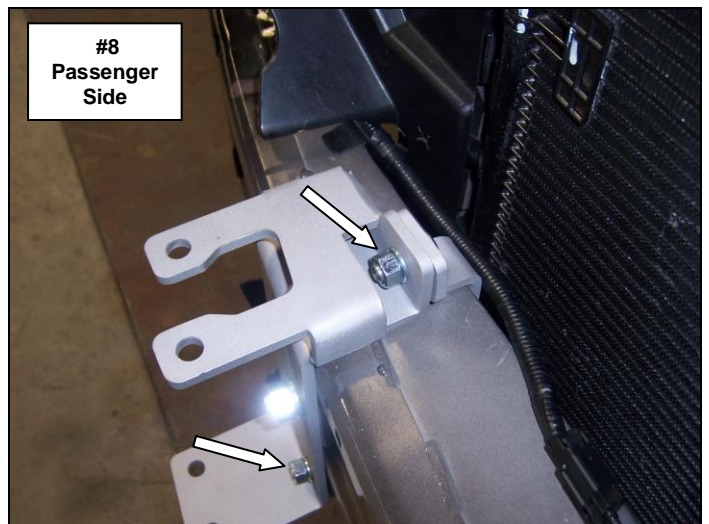

Step-4 Position the driver side clamp bracket behind the impact beam and align the holes in the clamp bracket with the driver side main bracket. Secure the clamp bracket to the main bracket using (2) 3/8" x 1" carriage bolts, (2) 3/8" lock washers and (2) 3/8" hex nuts. **Picture #9 & #10** Leave the nuts and bolts loose for final adjustment.

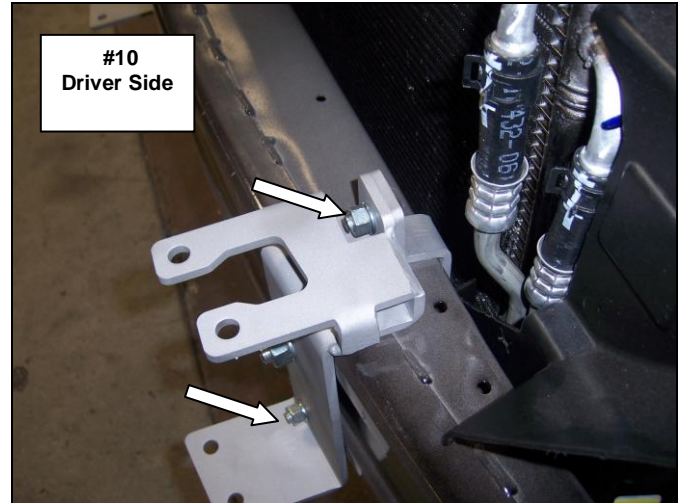
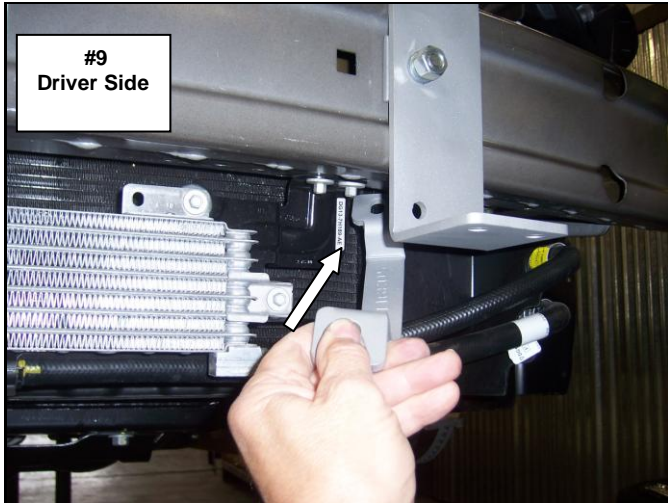

Step-5 Position the top and bottom edge of the passenger side main bracket approximately 11 1/4" from the end of the impact beam and tighten the main and clamp bracket assembly nuts and bolts. Repeat this step for the driver side. **Picture #11 & #12**

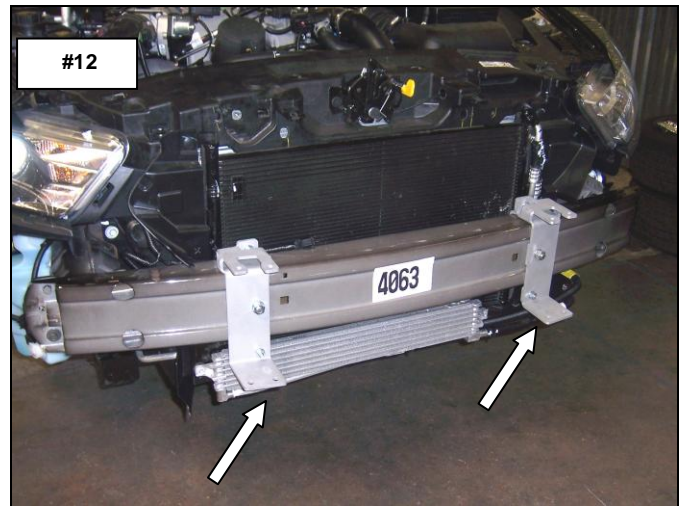
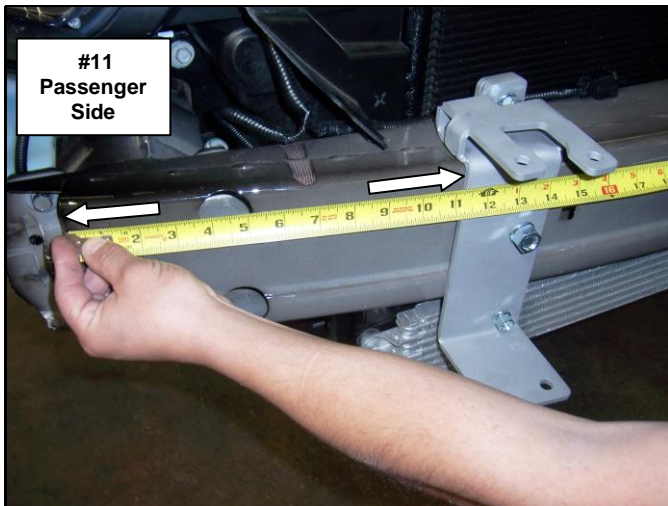

Step-6 The bumper insulator must be notched (top and bottom) to properly fit around the main brackets. Remove the insulator from the bumper fascia and position the insulator up to the bumper and mark the main bracket locations. Notch the insulator and check fit by returning the insulator to the impact beam until the proper fit is achieved. **Picture #13 & #14**

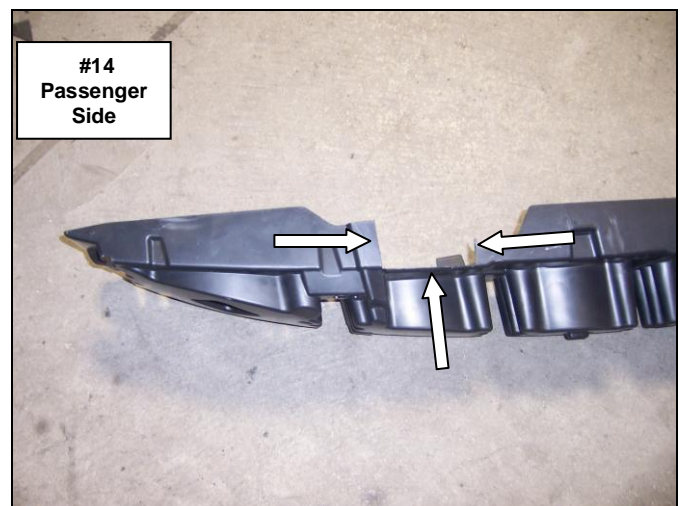
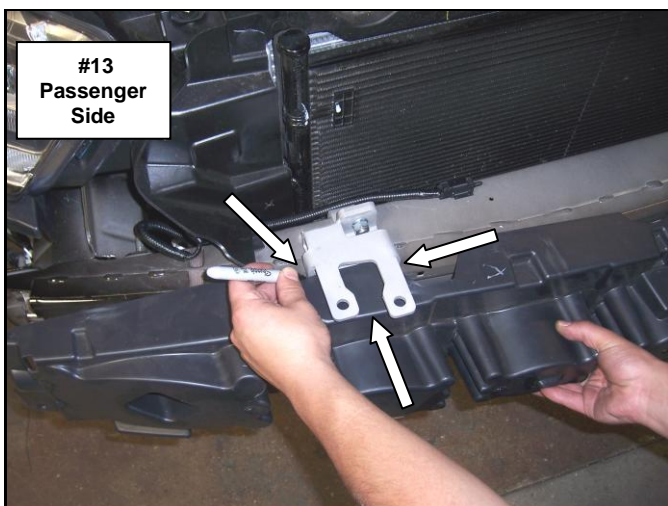

Step-7 Reinstall the bumper insulator to the fascia and bumper fascia to the vehicle. **Picture #15**

Step-8 Attach the passenger side upper and lower extension brackets to the main bracket using (2) 3/8" x 1" hex bolts, (2) 3/8" lock washers and (2) 3/8" hex nuts. **Picture #16** Leave the nuts and bolts loose for final adjustment. Repeat this step for the driver side.

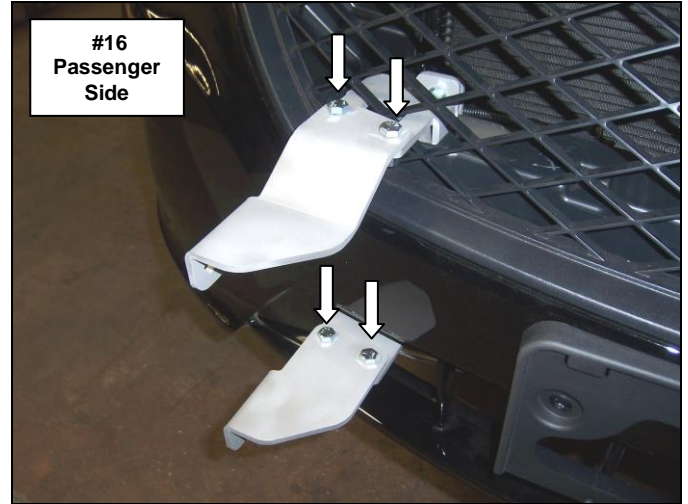

Step-9 Attach the push bumper to each of the extension brackets using (2) 3/8" x 1" hex bolts, (2) 3/8" lock washers and (2) 3/8" hex nuts. Leave the nuts and bolts loose for final adjustment. **Picture #17 & #18**

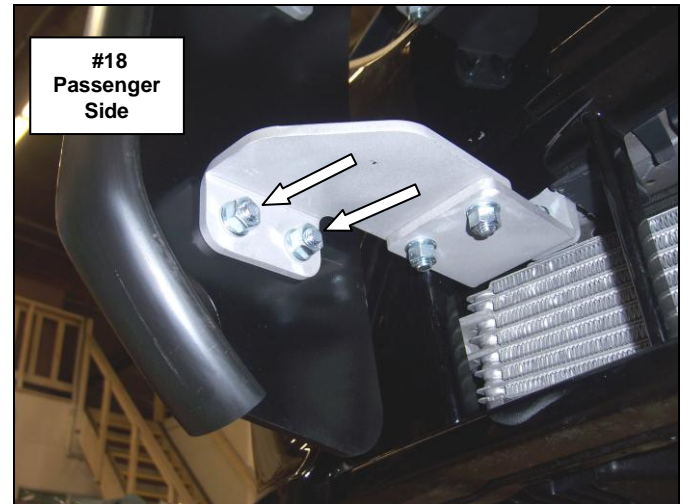

Step-10 Align the push bumper with the vehicle and tighten all nuts and bolts. **Picture #19 & #20**

