

INSTALLATION INSTRUCTIONS

523335

2009 - CURRENT FORD F150

Parts List:

ITEM	QTY.	CODE	DESCRIPTION	TORQUE MAX.
1	1		Bull Bar (Sold Separate)	-
	1	BRK-52333	Brackets kit includes:	-
2	1	523334AA	Main brackets set	-
3	1	523332AA	Auxiliary bracket set	-
4	4	5016472	1/2" Rod bolt	75 Lb.Ft
	1	KTE-52133	Hardware kit includes:	-
5	2		1/2 x 2" Hex head bolt, zinc plated	75 Lb.Ft
6	6		1/2" Flat washer, zinc plated	-
7	6		1/2" Lock washer, zinc plated	-
8	4		1/2" Hex nut, zinc plated	75 Lb.Ft
9	1		1/2" Bolt guide	-

Required Tools (no included)

DESCRIPTION	QTY.
15 mm Socket / Wrench	1
3/4" Socket / Wrench	1
Ratchet	1
Ratchet extension	1

ILLUSTRATION 1

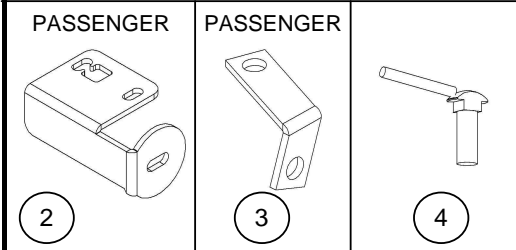
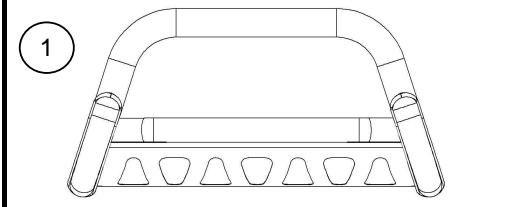

Instructions:

Approximated installation time: 40 min.

ILLUSTRATION 2

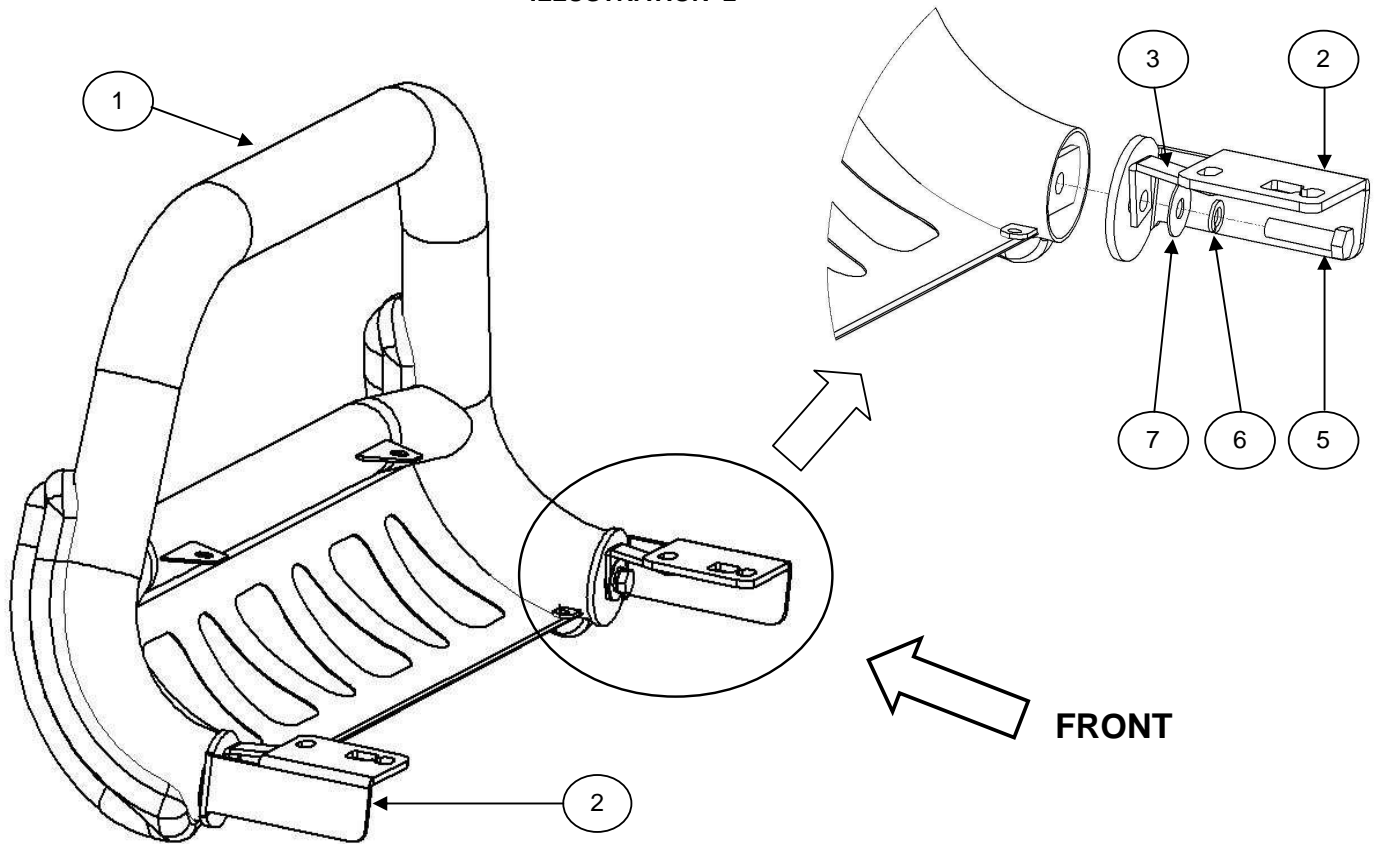

Cleaning and care instructions:

Design:

Quality:

Protect the finish with a non-abrasive automotive wax, (e.g. Pure Carnauba) on a regular basis. The use of any soap, polish, or wax that contains an abrasive is detrimental to the finish, as the compounds scratch the finish and cause corrosion.

INSTALLATION INSTRUCTIONS

523335

2009 - CURRENT FORD F150

1. Before beginning the installation, please read all directions carefully and verify that all necessary hardware is accounted for. If any parts are missing, stop the installation and contact your distributor immediately.
2. In order to install brackets, locate and remove the tow hooks that are located in the front of the vehicle, **see picture 1, illustration 3**. Tow hooks will not be used to continue installation.

PICTURE 1



In this part, the tow hooks are located.

ILLUSTRATION 3

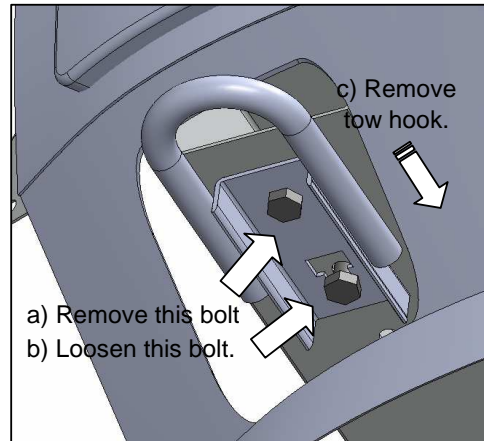

3. Installs bracket using the same bolt kit with attach the tow hooks. **See illustration 4**. Leave loose. It repeats for the opposite side.

Illustration 4 shows passenger side.

I continued in step 6.

4. If the vehicle does not have tow hooks, use the template, printed below, as a guide to modify the lower valance. **NOTE:** Before proceeding with the valance modification, make sure that the supplied paper template has the dimensions clearly printed and check them out. **PROFESSIONAL INSTALLATION RECOMMENDED.**

ILLUSTRATION 4

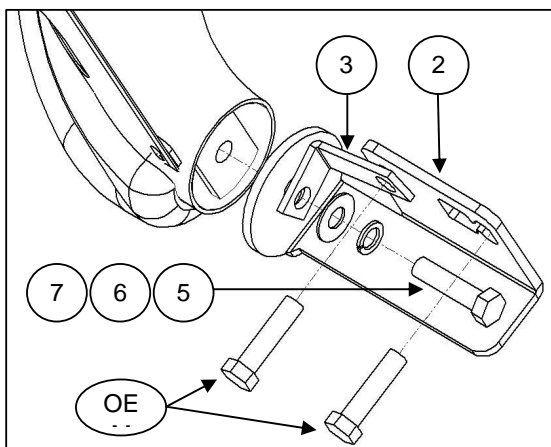

Installation passenger side.

PICTURE 2

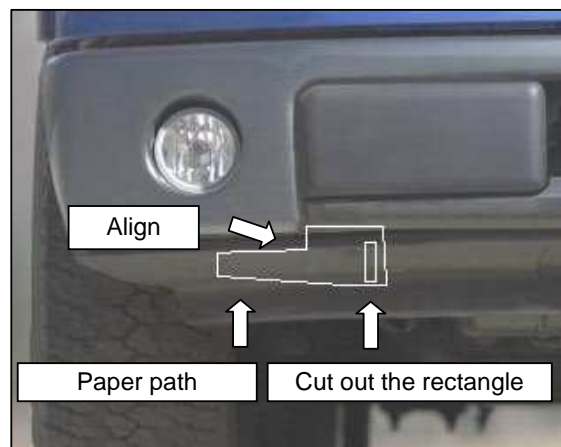

Picture, passenger side.

Cleaning and care instructions:

Protect the finish with a non-abrasive automotive wax, (e.g. Pure Carnauba) on a regular basis. The use of any soap, polish, or wax that contains an abrasive is detrimental to the finish, as the compounds scratch the finish and cause

Design:

Quality:

INSTALLATION INSTRUCTIONS

523335

2009 - CURRENT FORD F150

5. Align paper path to the edges shown at picture 2, mark area to cut out and proceed. Repeat for opposite side.
 - a).- Once openings were made, place tab bolts into the frame as shown at picture 3. Use the wire guide to place 1/2" rod bolts.
6. Identifies auxiliary bracket to install (See illustration 1) and attach with the same bolts of main bracket. See illustration 6 or 4. Leave loose.
7. Place bull Bar Sport to the main brackets and auxiliary brackets and attach with: (1) 1/2 x 2" hex head bolt, (1) 1/2" flat and lock washers. By each bracket. Leave loose. See illustration 2.
8. Align the sidebar to the vehicle and tighten all hardware.
9. Repeat for the other side of vehicle.
10. Fill out the warranty card included and place it inside your vehicle.

ILLUSTRATION 5

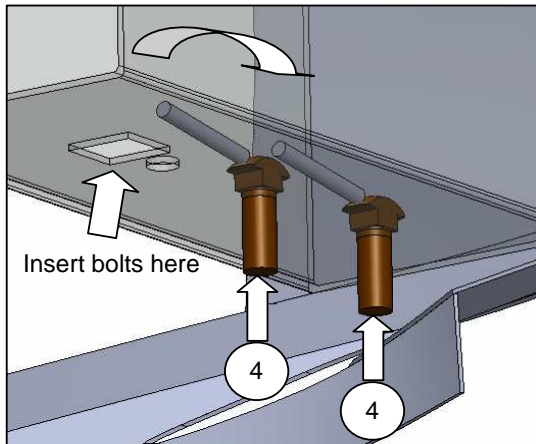
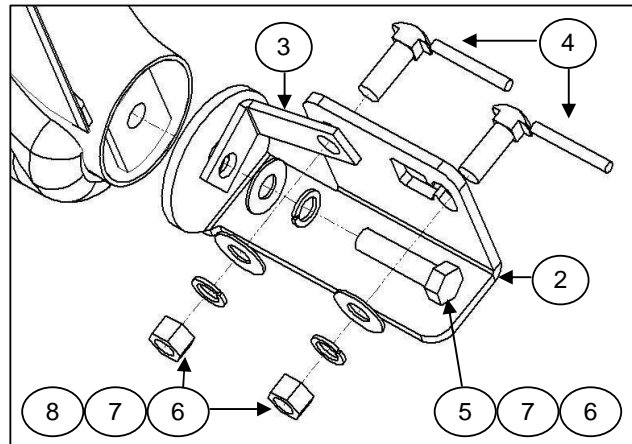

ILLUSTRATION 6



PICTURE 3



BULL BAR INSTALLED

Cleaning and care instructions:

Protect the finish with a non-abrasive automotive wax, (e.g. Pure Carnauba) on a regular basis. The use of any soap, polish, or wax that contains an abrasive is detrimental to the finish, as the compounds scratch the finish and cause corrosion.

Design:

Quality:

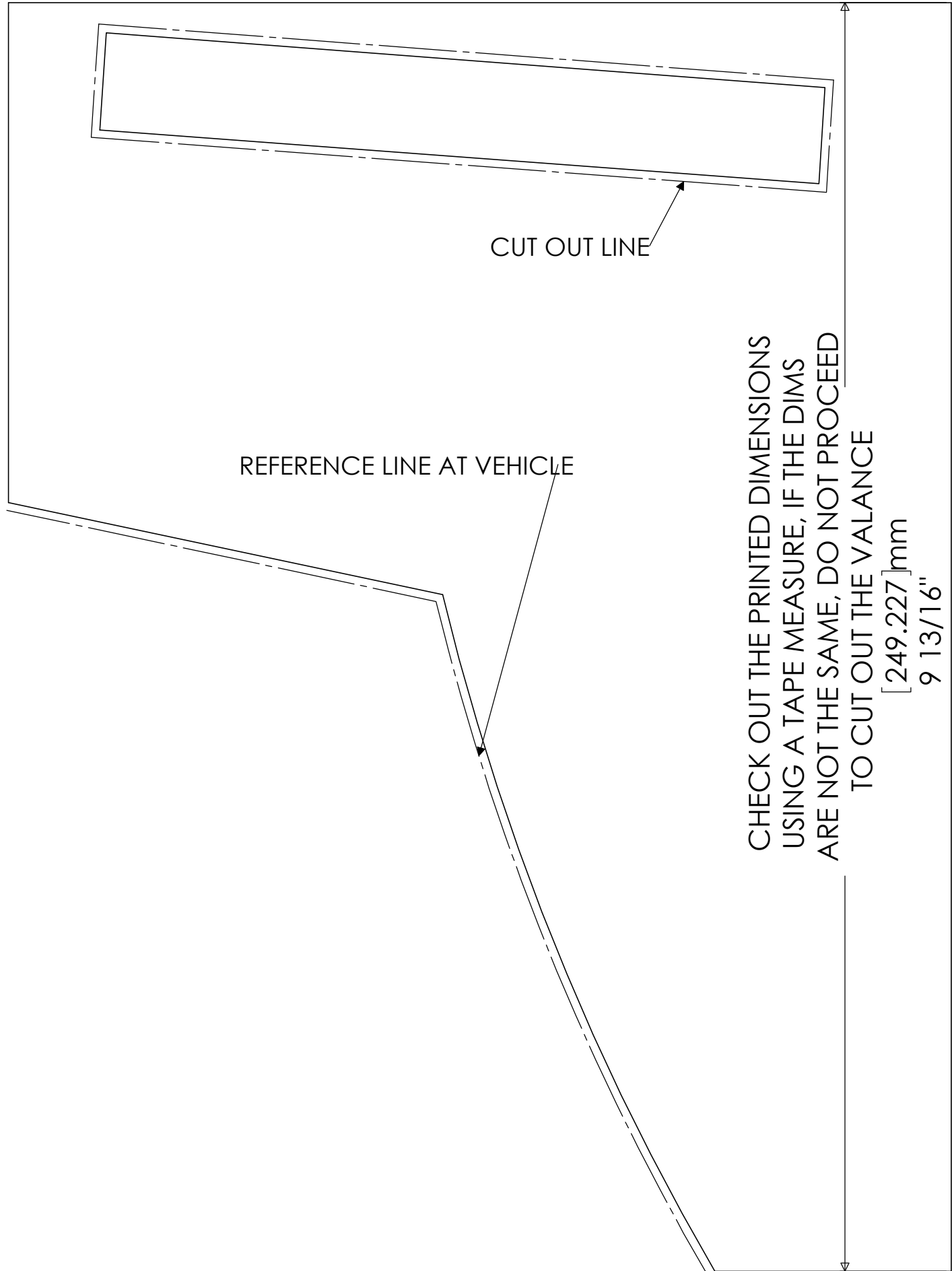

CUT OUT LINE

REFERENCE LINE AT VEHICLE

CHECK OUT THE PRINTED DIMENSIONS
USING A TAPE MEASURE, IF THE DIMS
ARE NOT THE SAME, DO NOT PROCEED
TO CUT OUT THE VALANCE
[249.227]mm
9 13/16"