

INSTALLATION INSTRUCTIONS

**Dakar Sport 52133(1-4) / Dakar 52133(1BB-4BB) / Rhino Charger BB52133(1B-4PS)
2004 - 2008 Ford Pick Up F-Series**

Parts List :

QTY	(1) Hardware kit including :
(1) Dakar sport	(2) 1/2 x 2" Hex head bolts
(2) Mounting brackets (Driver & Passenger)	(6) 1/2" Flat washers
(4) Tab bolts	(6) 1/2" Lock washers
	(4) 1/2" Hex nuts
	(1) Bolt guide

Tools Required :

3/4" Socket
10 mm Socket
Ratchet

Instructions :

Approximated installation time: 25 min.

1. Read and understand instructions completely before beginning installation. *If vehicle is not equipped with tow hooks, proceed to step 4.*
2. If equipped with tow hooks, remove front tow hook bolt and loose rear bolt so that tow hook slides off bolt, as shown in Picture 1. Repeat for the opposite side. **Note:** By keeping rear bolt threaded, it will facilitate installation of main mounting brackets.
3. Place mounting bracket between tow hook and vehicle frame and secure using existing bolts. Picture 2 & 3. Leave loose. If equipped with tow hooks proceed to step 6.
4. If **NOT** equipped with tow hooks, it will be necessary to cut off a 3/8 x 2 1/2" slot per side in the vehicle lower bumper balance to pass through the mounting brackets. The slots must be 38 1/2" between interior edges. See picture 6 and Illustration 1 for more references.
5. Locate the existing holes in the frame rail as shown in Picture 4, then introduce the tab bolts. Picture 5. **Note:** Use the bolt guide to pass through existing holes the tab bolts. Place mounting brackets and secure to the tab bolts using a 1/2" flat & lock washers and hex nuts. Leave loose.
6. Place the Dakar sport up to the mounting brackets and bolt them together using 1/2 x 2" hex head bolts, flat and lock washers. Leave hardware loose.
7. Make any final adjustments to the alignment of the Dakar sport and tighten all bolts.
8. You may need to periodically re-tighten the bolts.

Assembly Diagram :

Picture 1

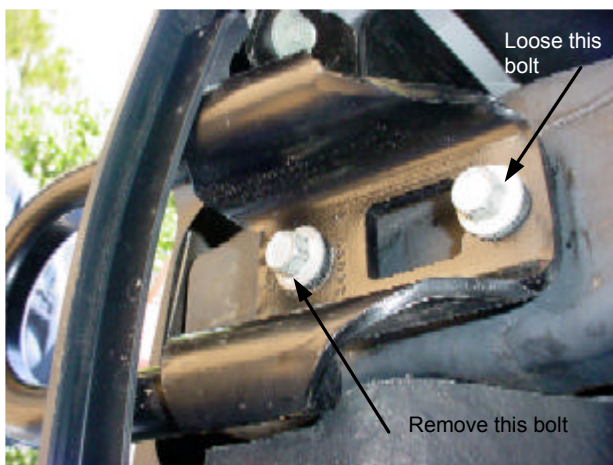

Picture 2

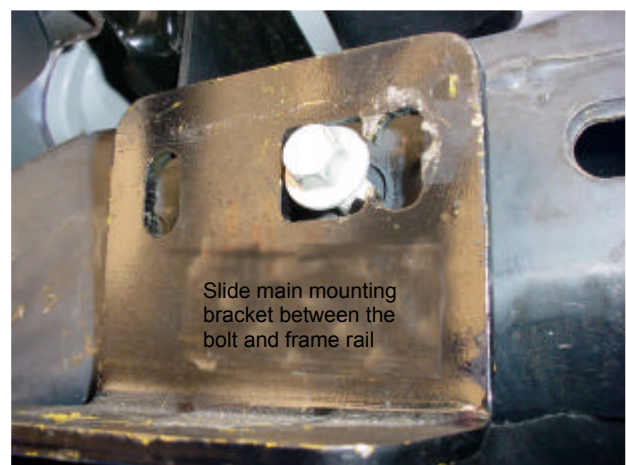

Cleaning and care instructions :

Design:

Quality:

Protect the finish with a non-abrasive automotive wax, (e.g. Pure Carnauba) on a regular basis. The use of any soap, polish, or wax that contains an abrasive is detrimental to the finish, as the compounds scratch the finish and cause corrosion.

INSTALLATION INSTRUCTIONS

Dakar Sport 52133(1-4) / Dakar 52133(1BB-4BB) / Rhino Charger BB52133(1B-4PS)
2004 - 2008 Ford Pick Up F-Series

Picture 3

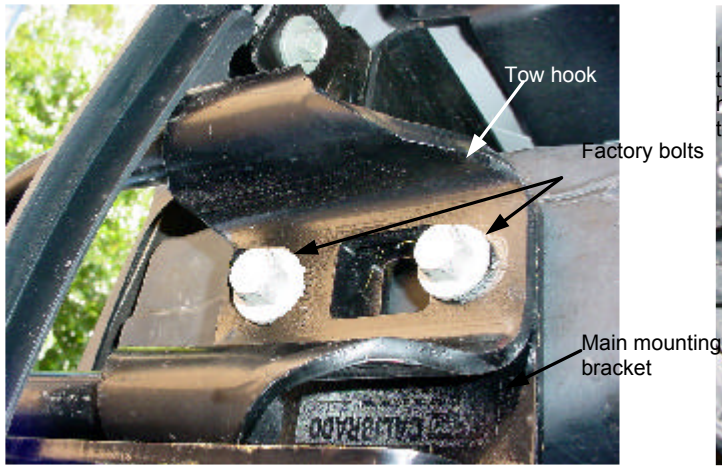

Picture 4

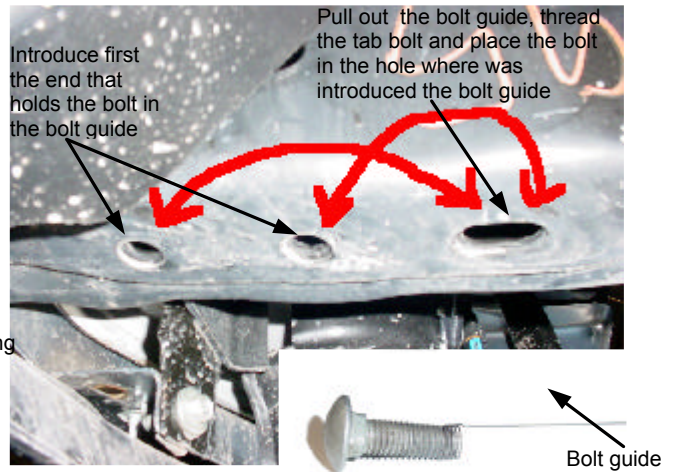

Picture 5

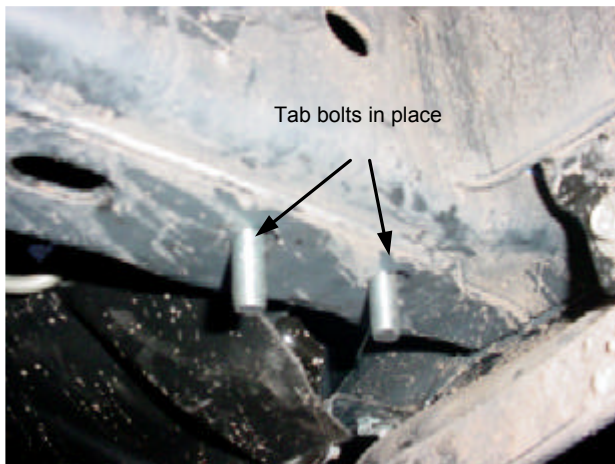

Picture 6



Illustration 1

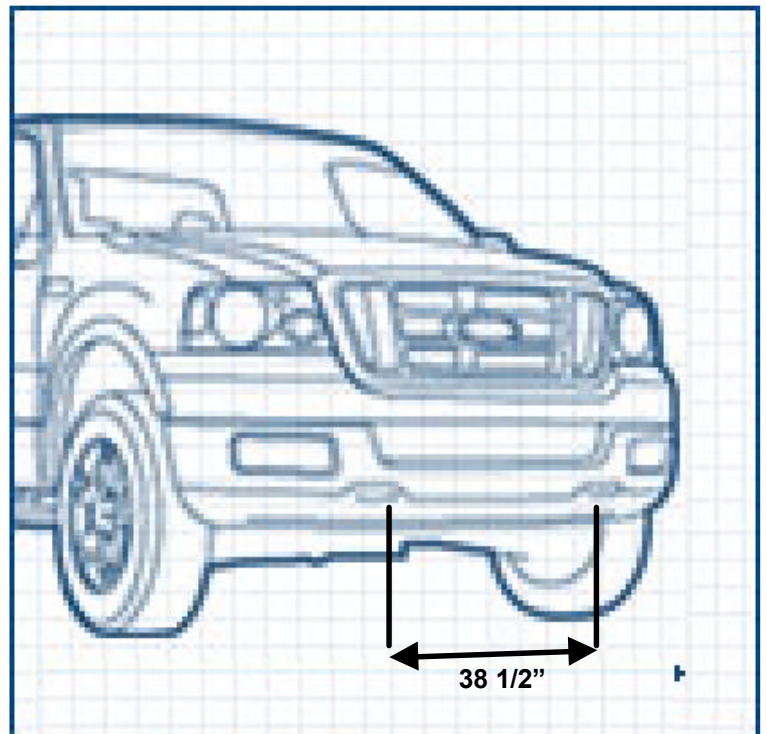

Cleaning and care instructions :

Protect the finish with a non-abrasive automotive wax, (e.g. Pure Carnauba) on a regular basis. The use of any soap, polish, or wax that contains an abrasive is detrimental to the finish, as the compounds scratch the finish and cause corrosion.

Design:

Quality: