

INSTALLATION GUIDE



Power Step

MADE IN USA TM



APPLICATION

Jeep Wrangler JT Gladiator
(For Gas and Diesel models)

2020 - 2024

AMP Part

77135-01A

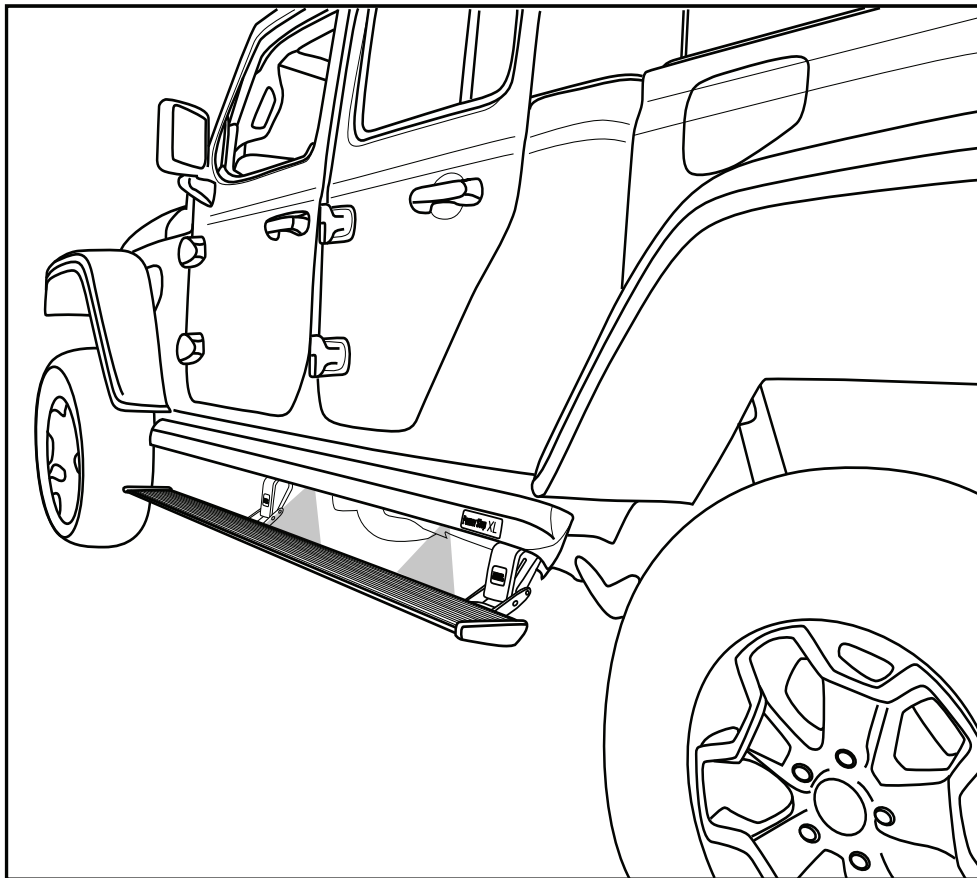

INSTALLATION TIME

3-5 Hours

Professional installation recommended

SKILL LEVEL



4= Experienced

TOOLS REQUIRED

- Safety goggles
- Measuring tape
- 10 mm socket
- 13 mm socket
- 1/2" socket
- Ratchet wrench and extension
- Wire crimpers
- Wire stripper / cutter
- 3/16" hex key wrench (allen wrench)
- 4mm hex key wrench (allen wrench)
- Electrical tape
- Weather proof caulking (silicone sealer)
- Silicone spray

WARRANTY

5-Year Limited Warranty

AMP RESEARCH TECH SUPPORT 1-888-983-2204 (Press 2) Monday - Friday, 7:00 AM - 5:00 PM PST

Invented, engineered and manufactured exclusively by AMP Research in the USA. May be covered by one OR MORE of the following patents: 6,641,158; 6,830,257; 6,834,875; 6,938,909; 7,055,839; 7,380,807; 7,413,204; 7,398,985; 7,584,975; 7,566,064; 7,487,986; 8,157,277; 8,408,571; 9,302,626; 9,561,751; 10,053,017; CA2463717 ©2023 AMP Research. All rights reserved. Printed in USA.

EXPLODED VIEW

- Motor
- Hex Head Bolts

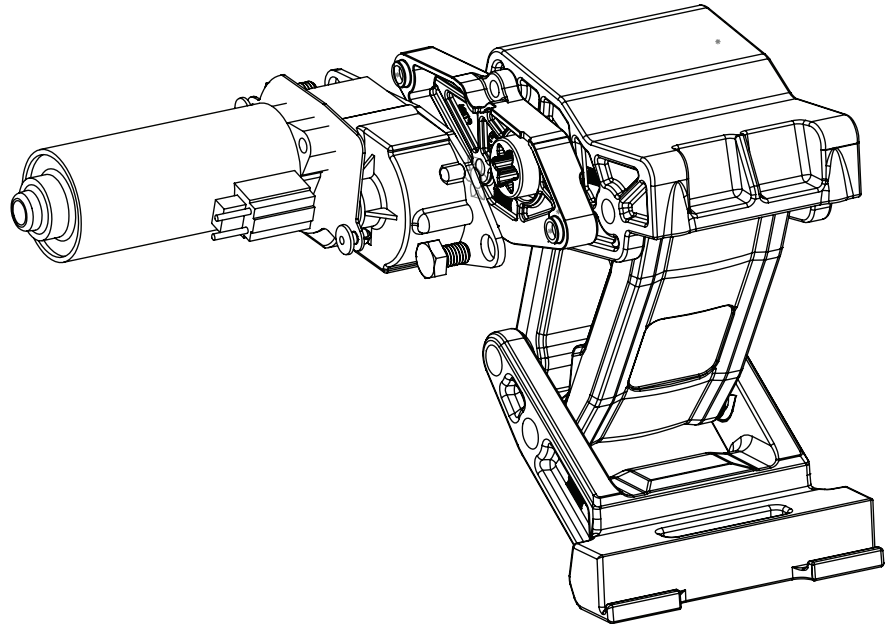

CAUTION: HANDLE WITH CARE.

To ensure our customers receive all components with full integrity, we pack the motors separate from their linkage assemblies. This requires that the installer position and fasten the motor before continuing with the install. Please follow the instructions below and handle the assembly carefully.

CAUTION: Dropping the assembly or any excessive impact MAY cause damage to the motor.

Instructions:

1. Position the gear cover in place as shown if not already in place.
2. Seat motor into position on the two mounting bosses. This may require an adjustment of the gear by moving the swing arms.
3. After seating into place, fasten the motor with the two motor mount bolts with 13mm Wrench. Tighten bolts to 36 in-lbs (4N-m). **Do not over torque.**

AMP RESEARCH POWERSTEP™ – Jeep Wrangler JT

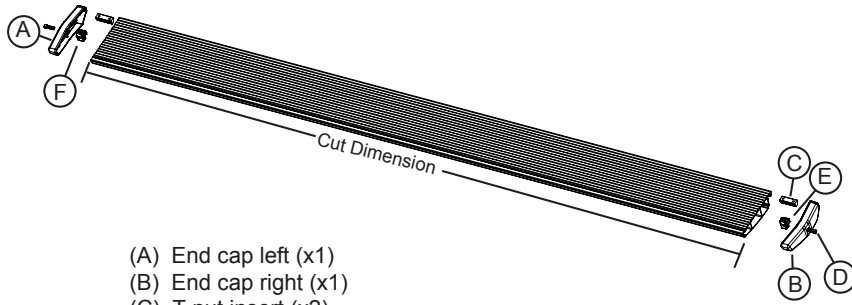

- (A) End cap left (x1)
- (B) End cap right (x1)
- (C) T-nut insert (x2)
- (D) Socket cap screw (x2)
- (E) End cap wedge right (x1)
- (F) End cap wedge left (x1)

1 x2

Running board assembly

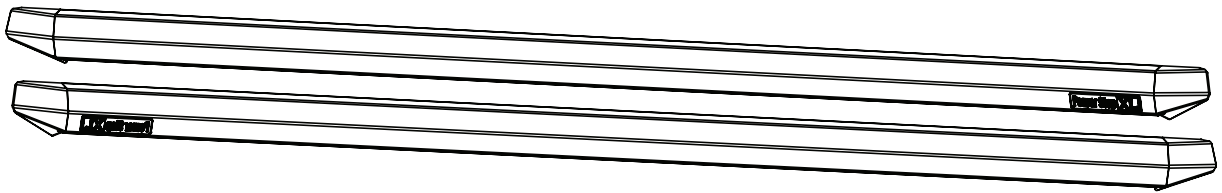

2 x2

Rail Assembly

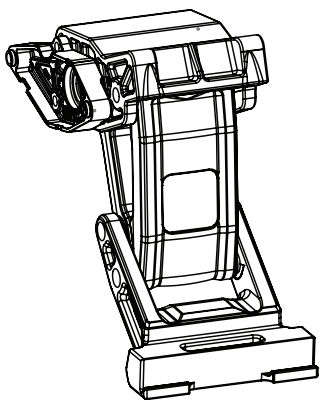

3 x2

Motor Linkage
assembly
Driver

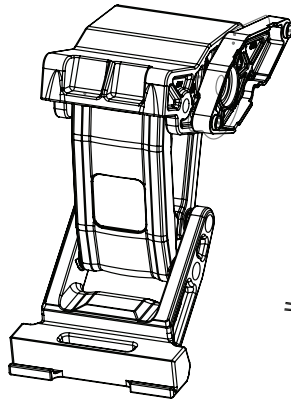

4 x2

Motor Linkage
assembly Passenger

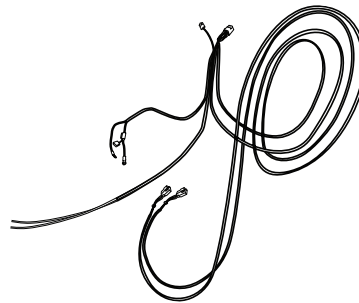

5

Wire harness

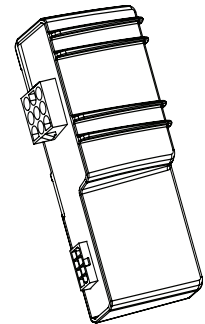

6

Controller XTA

AMP RESEARCH POWERSTEP™ – Jeep JT Gladiator

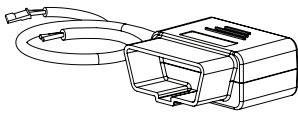

7
OBD Module

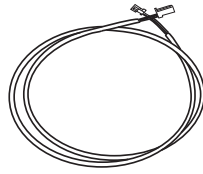

8
OBD Module extension

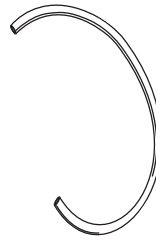

9
Tube (Installation Tool)



10 x2
Posi-Lock®

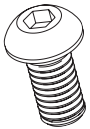

11 x10
M8 Button Head Bolt

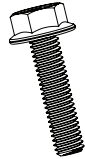

12 x4
M6 Flange Bolt

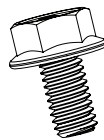

13 x4
5/16 Flange Bolt



14 x8
Socket Cap Screw

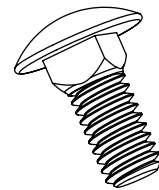

15 x14
5/16-18 Carriage Bolt

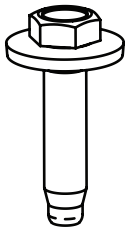

16 x12
M8 Hex Bolt w Conical washer

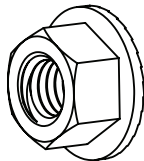

17 x18
5/16-18 Flange Nut

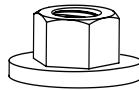

18 x10
Nut with Conical Washer



19 x14
Washer

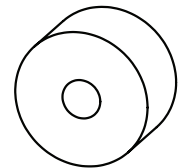

20 x4
Upper Mount Spacer

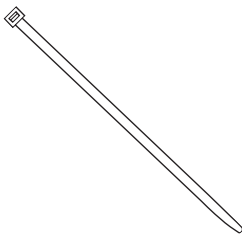

21 x20
Cable tie (7")

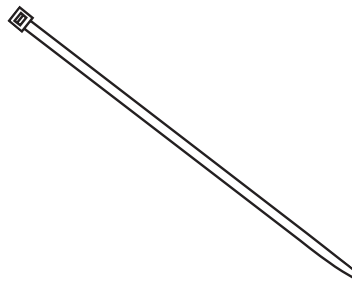

22 x2
Cable tie (11")

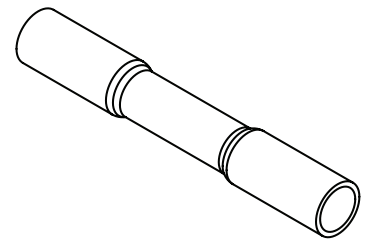

23 x8
Butt Connector

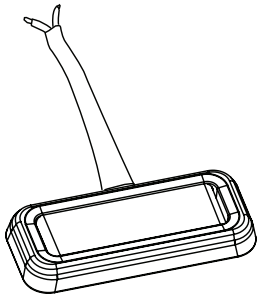

24 x4
LED Lamp

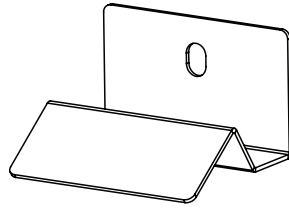

25 x4
LED Light Bracket

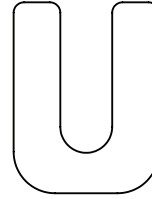

26 x2
Shim Spacer

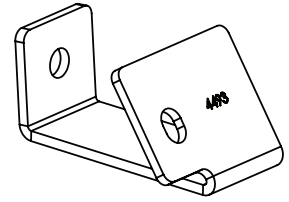

27 x2
Rail Support Bracket

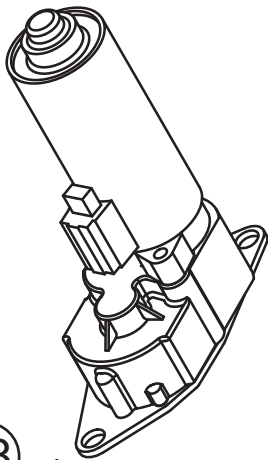

28 x4
CRH Motor



29 x12
Cinch Fastener

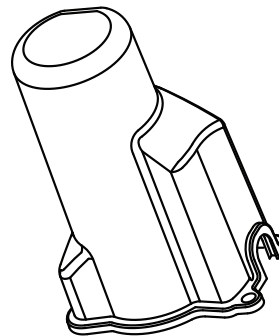

30 x4
Motor Cover

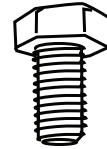

31 x8
M8 Head Hex Bolt

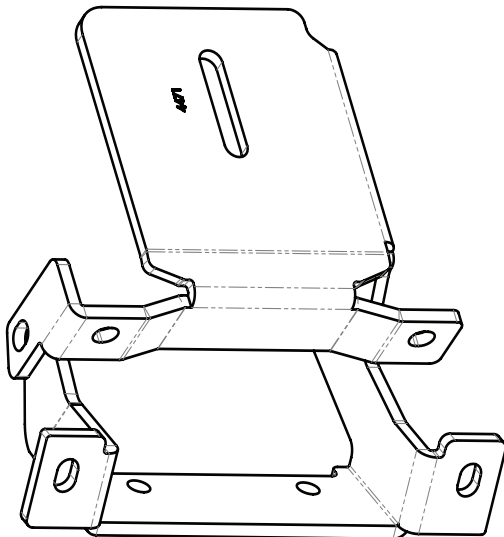

32 x2
Linkage mounting
Bracket (Driver)

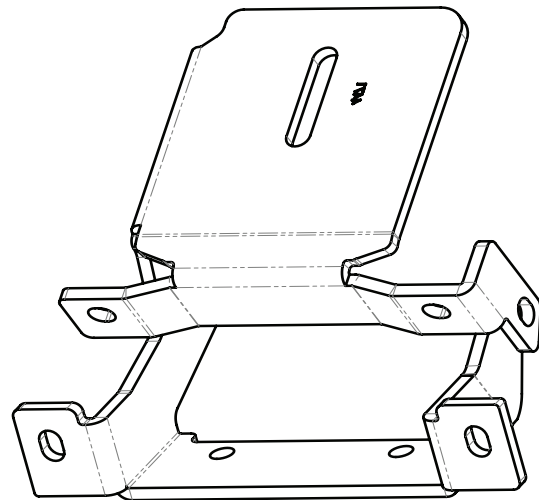

33 x2
Linkage mounting
Bracket (Passenger)

AMP RESEARCH POWERSTEP™ – Jeep Wrangler JT

Assemble brackets onto vehicle. Use provided button head bolts (11) and washers (19) at pinch weld with captive washer nuts (18) at pinch weld. Assemble hardware loosely. Next use provided conical washer bolts (16) to attach bracket to underside of body. On front mount assemble shim (26) between floor mount and bracket as shown. Use Right facing brackets on driver side. Mirror for passenger side. **Note: Driver side shown.**

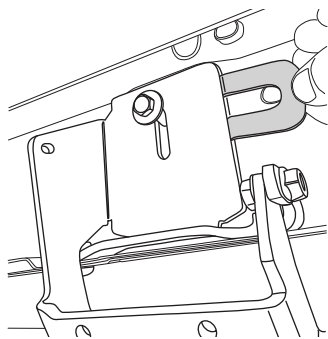
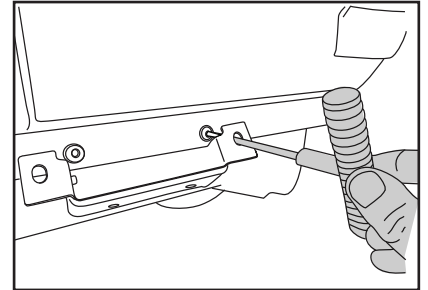
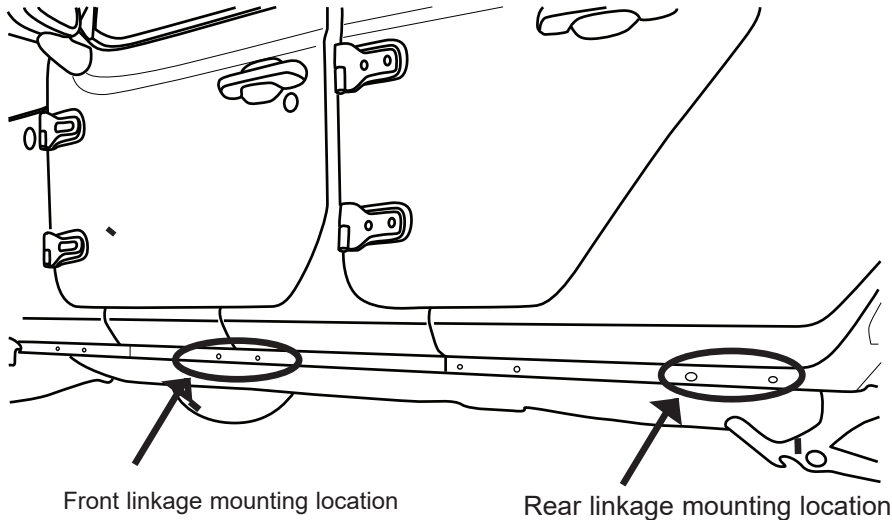

1 Front Mounting Bracket

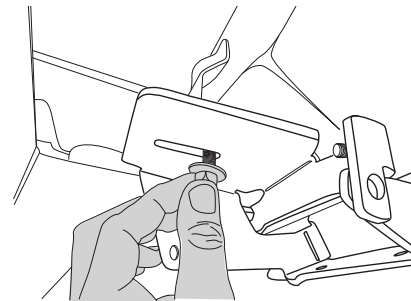

Rear Mounting Bracket

Slide 6 carriage bolts (15) into rail pocket of driver side rail. Add Light Bracket (25) to the 1st and 4th bolt counting from the front of the vehicle (see image below). Insert Flange Nut (17) onto bracket tab to attach light brackets into position shown. Leave loose to allow for adjustment. Mirror for passenger side.

Note: Driver side shown.

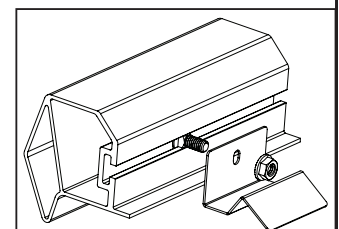
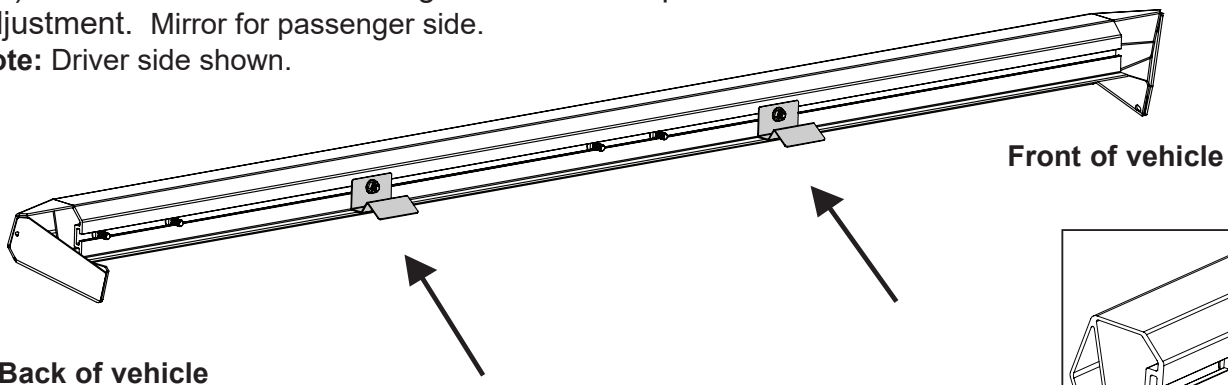

2

AMP RESEARCH POWERSTEP™ – Jeep Wrangler JT

Adjust bolts and slide over brackets. Use supplied flange nuts and attach rail to brackets. Center rail between body rocker and torque 4 flange nuts to 16 ft-lbs. Assemble Flange bolt (13) with nut (17) thru support tab on bracket as shown. Torque to 16ft-lbs. Leave loose to allow for adjustment.
Note: Driver side shown.

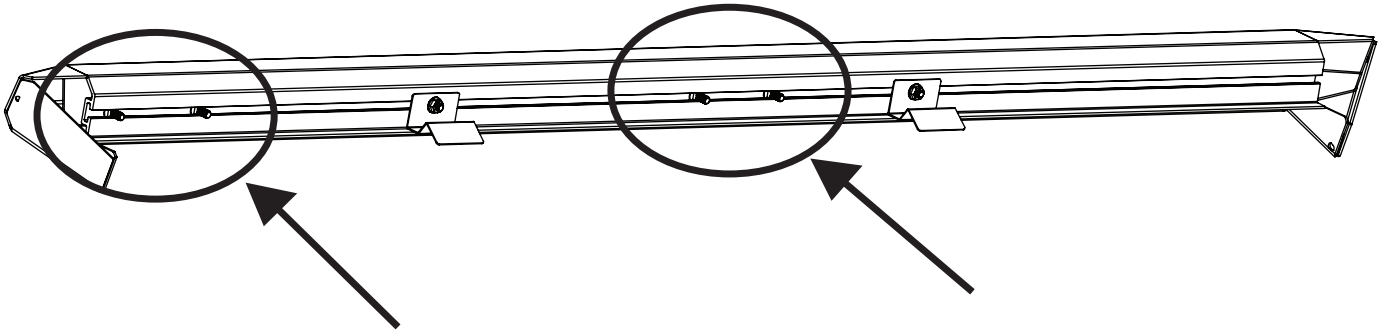

3

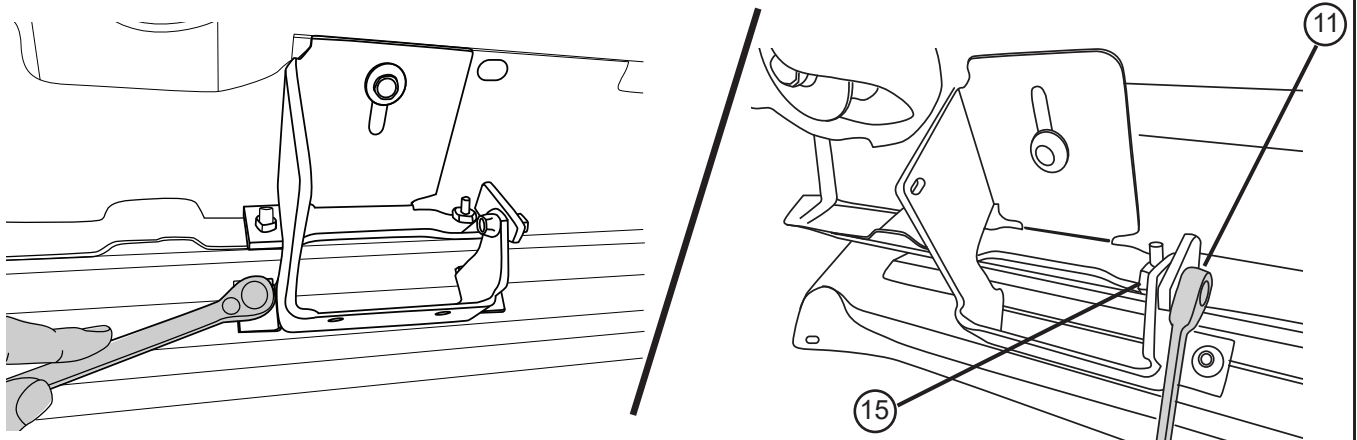

Attach rail support bracket (27) by inserting carriage bolt (15) into rail from the front of vehicle side, use flange nut (17) to attach it. Using supplied button head bolt (11), washer (19) and captive washer nut (18) to pinch weld. Torque bolts to 16ft-lbs.

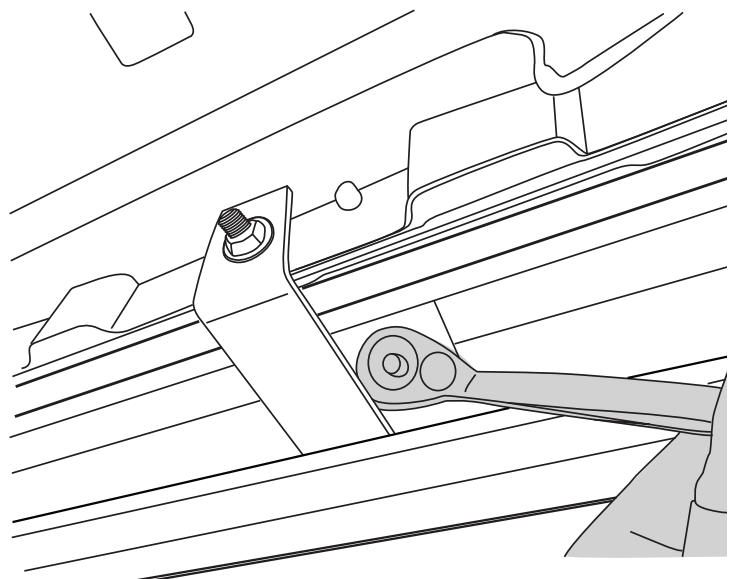

4

AMP RESEARCH POWERSTEP™ – Jeep Wrangler JT

Mount front drive linkage onto driver side. Thread supplied M8 Hex bolts (16) into front drive linkage. Repeat step for Rear idler linkage. Do not tighten.

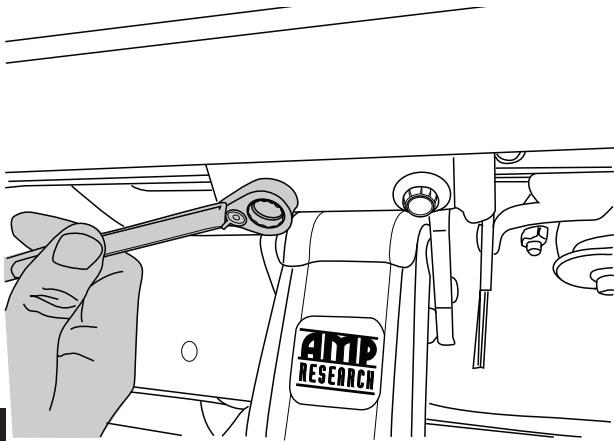

5

Install provided spacer (20) and M6 bolt (12) into upper mount as shown on both the drive and idler linkages. Do not tighten.

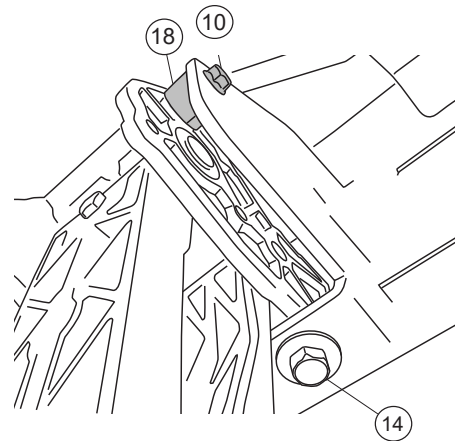

6

Slide mounting T-nut into position. Center board in rail pocket. Tighten fasteners to 10 ft-lbs.

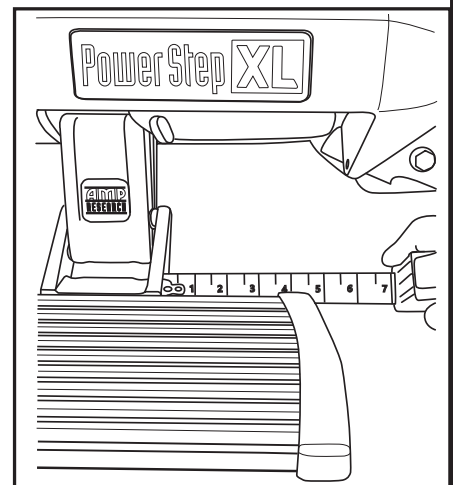
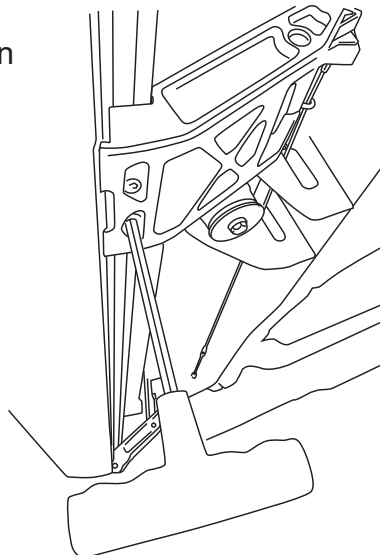

7

Using a 13mm socket Torque linkage bolts 4x (16) from step 5 to 16 ft-lbs. Next use a 10mm socket, torque linkage spacer bolt 2x (12) from step 6 to 8 ft-lbs. Once linkages are tight cycle board to verify steps deploy under own weight.

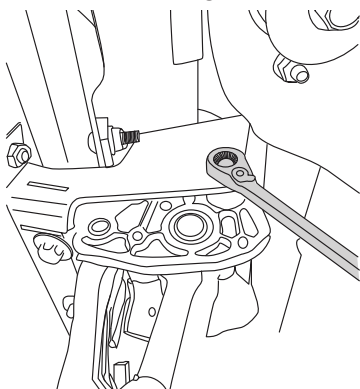

8

Attach motor to linkage. Using a 13mm wrench Torque to 36 in-lbs.

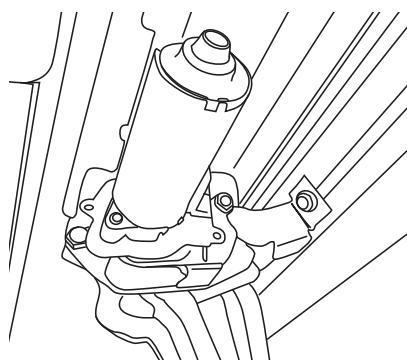

9

Remove fuse from Power Step Wire Harness.

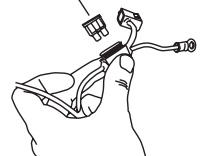

**Gas Models follow steps 10 and 11 then go to step 14.
Diesel models go to step 12.**

Prepare large tie-wraps (22) for mounting Power Step Controller(6). Loosely loop tie-wraps around large bundle of wires behind battery in engine compartment. Insert controller into tie-wrap loops and cinch down securely. The tie-wraps should cinch down into channels on controller surface. Connect power leads from Controller, Red to positive battery terminal and Black to the vehicle body ground as shown.

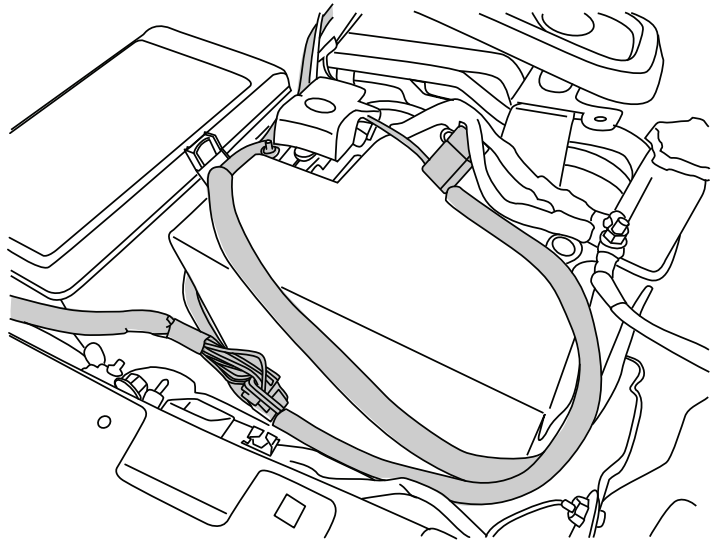

10

Route the two Wire Harness legs down over the wheel wells toward Motor Linkages, long leg across to the driver side. Secure harness with tie wraps(21).

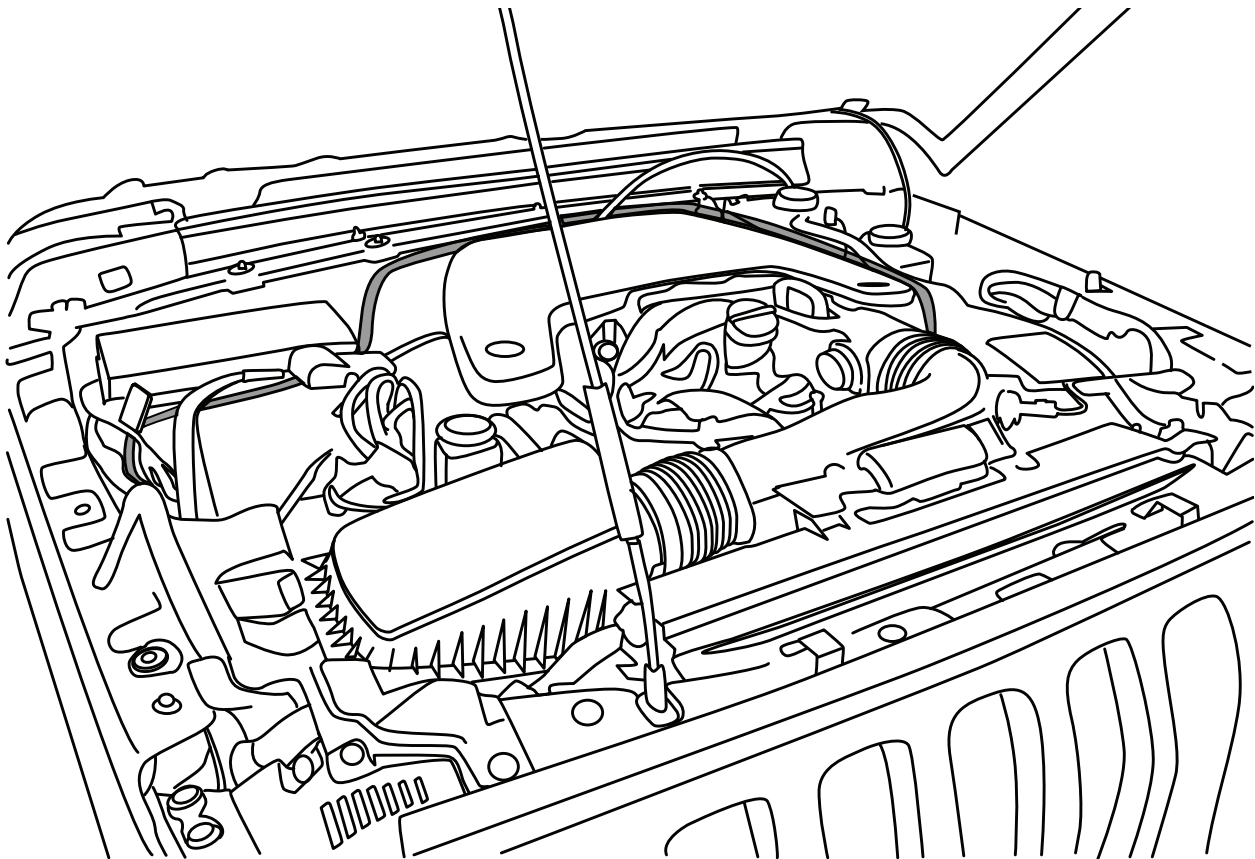

11

***Diesel models follow steps 12 and 13.
Gas models go to step 14.***

DIESEL MODELS ONLY: Remove fuse from Power Step Wire Harness. Prepare large tie-wraps(22) for mounting Power Step Controller (6). Loosely loop tie-wraps around large bundle of wires behind battery in engine compartment. Insert controller into tie-wrap loops and cinch down securely. The tie-wraps should cinch down into channels on controller surface. Connect power leads from Controller, Red to positive battery terminal and Black to the vehicle body ground as shown.

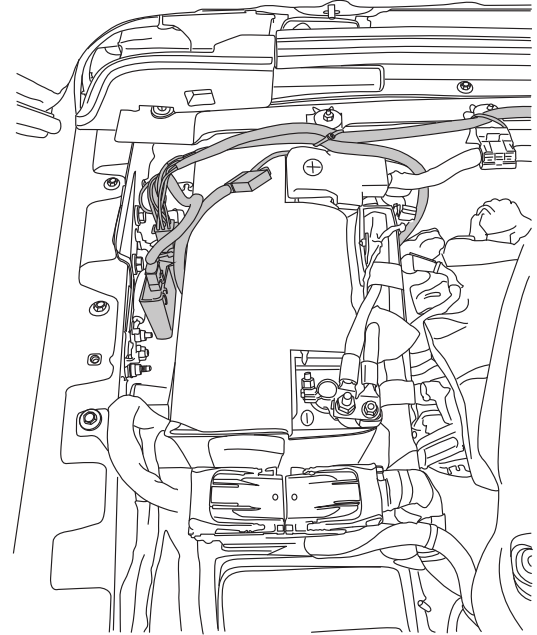

12

DIESEL MODELS ONLY: Route longer harness Leg across to driver side . Secure harness to cowl with tie wraps (21) to keep harness away from hot engine components. Next route harness under Coolant recovery tank then down and to the outside of the frame rails. Route shorter harness leg down the passenger side ensuring the harness is run to the outside of the frame rails and away from any hot exhaust components. Secure harness with tie wraps (21).

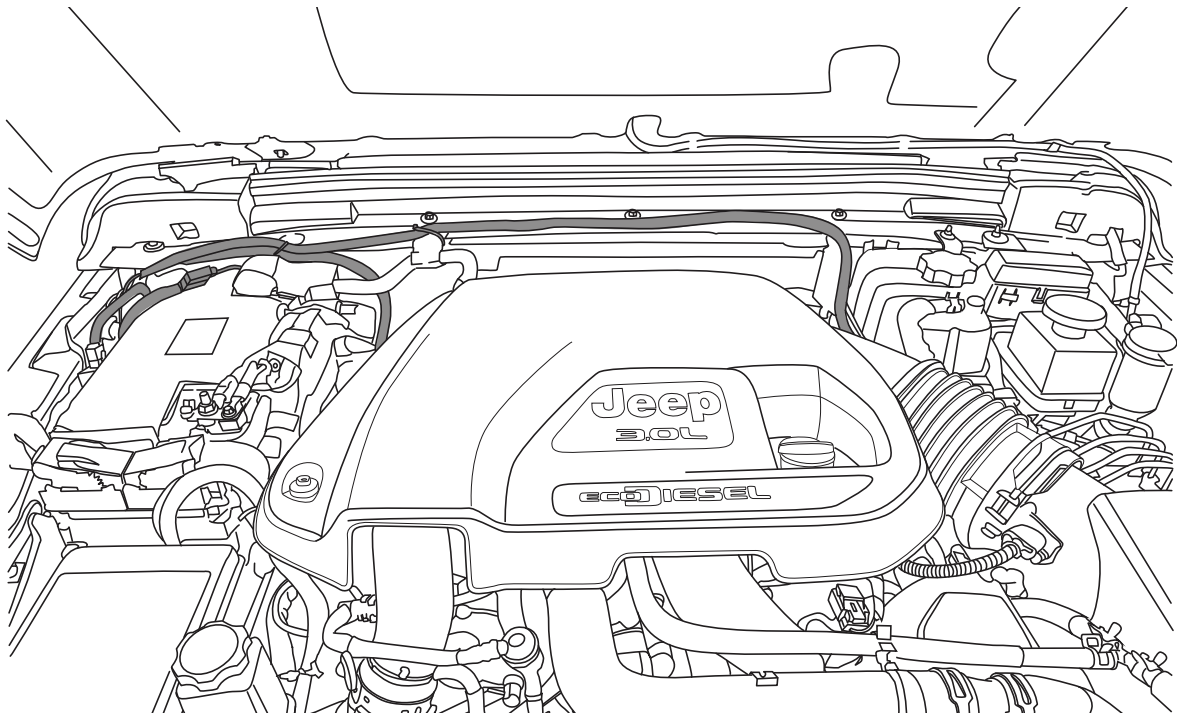

13

Press and release glove box safety tab to fully open and remove glove box, next, release glove box dampener located on the left side.

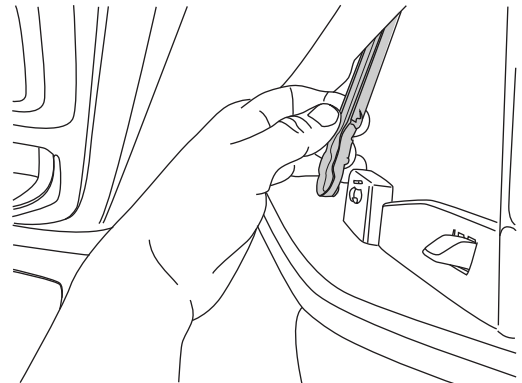
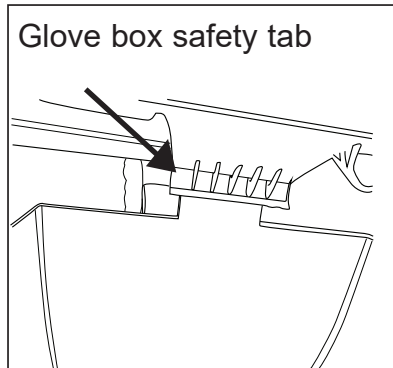

14

Carefully leave glove box hanging to expose plugs behind it.

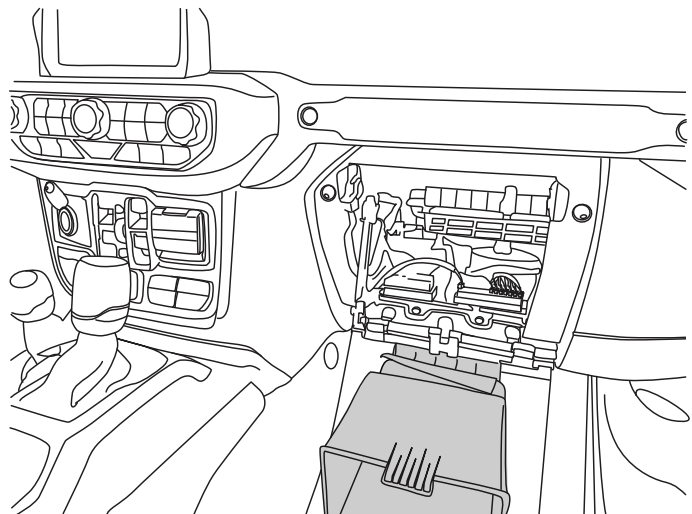

15

Locate white block (on right side) and plug the 2 pin connector from the OBD module extension (8) into that port.

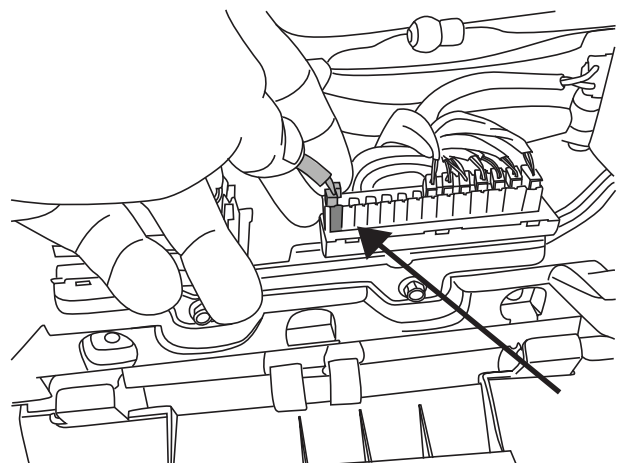
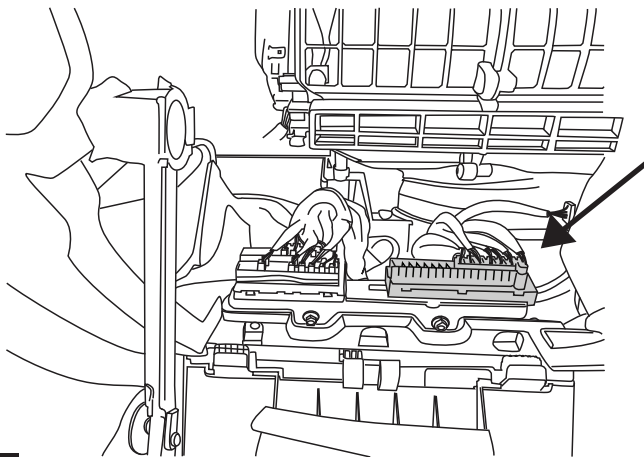

16

Pull back carpet on passenger side on the top side of middle console and then use provided Tube (9) to route OBD II Extension (8) behind middle console. Tape open end of extension to the tube and push the tube through middle console.

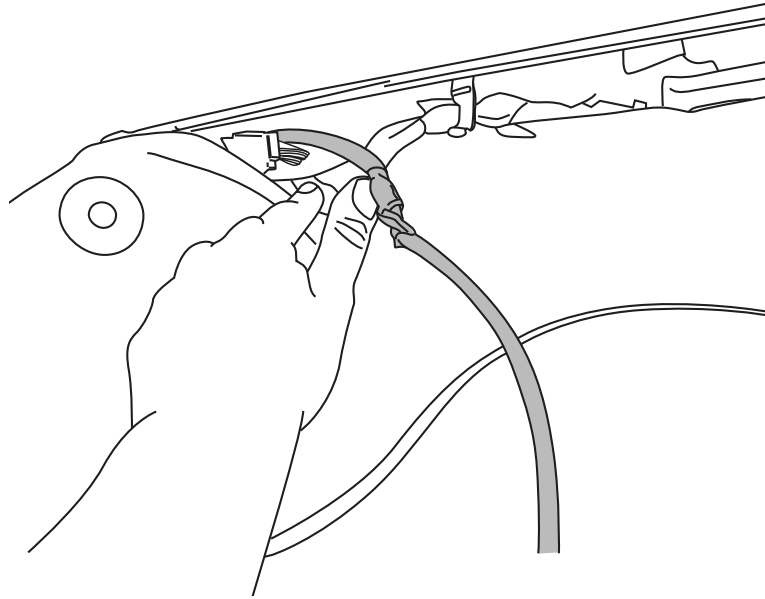

17

From driver side, pull tube (9) that was pushed through from passenger side.

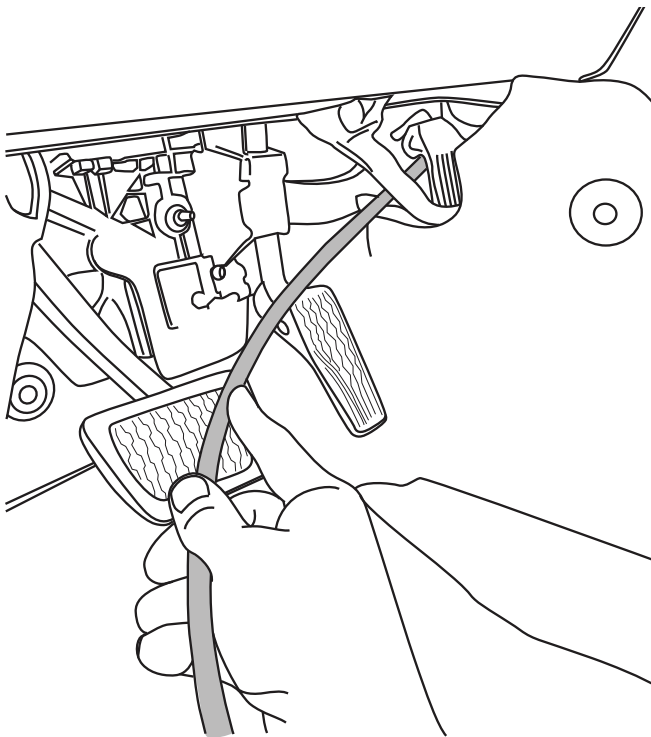

18

Remove OBD II Extension (8) from tube (9) and plug wire (8) to OBD module (7) wire.

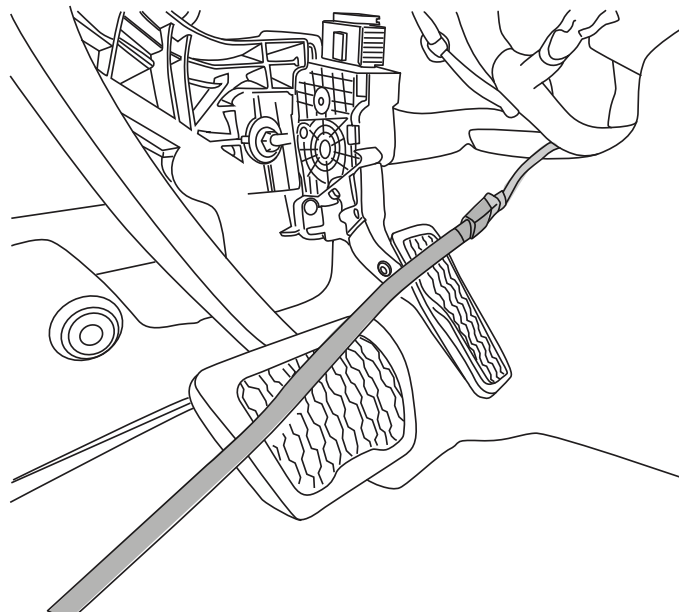

19

Route trigger wires through firewall. Locate round plastic plug on firewall to the left of the brake assembly. Drill small hole using a 3/16 drill bit. Route trigger wires (5) through firewall. Use supplied posi-lock® (10) to connect wires to OBD Module (7).

Apply silicone to seal off firewall.

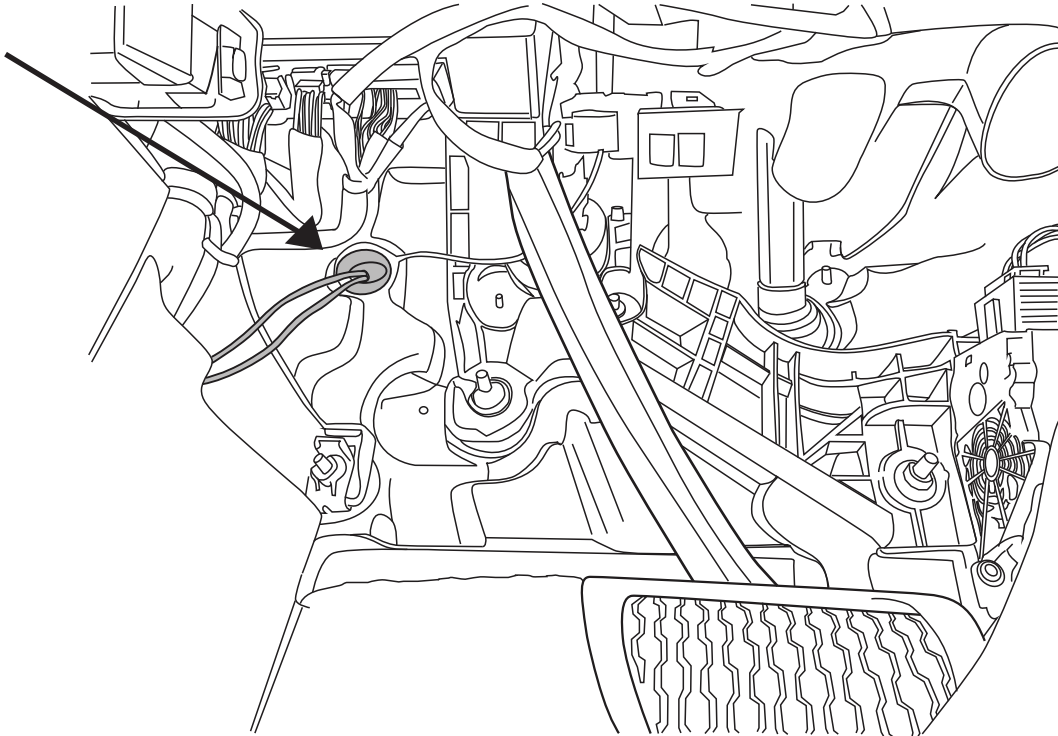

20

Use cable ties (21) to secure all wires in place. Plug in OBD Module (7).

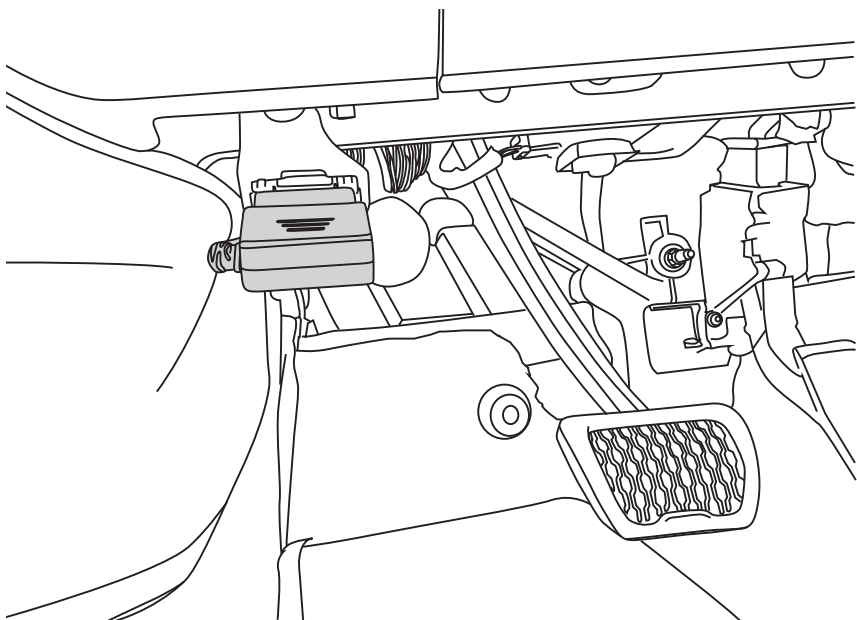

21

OBD II install: Use Supplied Posi-Lock® connectors to attach the Plug and Play Module to the Harness. Attach matching colors on the harness to the wires on the module. Plug in module to OBD II port on the vehicle. Secure harness with supplied tie wraps.

Note: If the OBD II pass thru harness (76404-01A) was purchased see install sheet supplied in packaging. The pass through harness allows for an open port for other accessories. See below for a brief description.

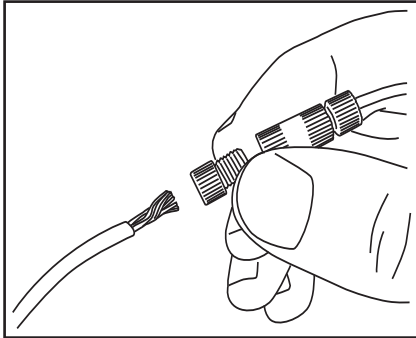

OBD II Connector located below steering column.

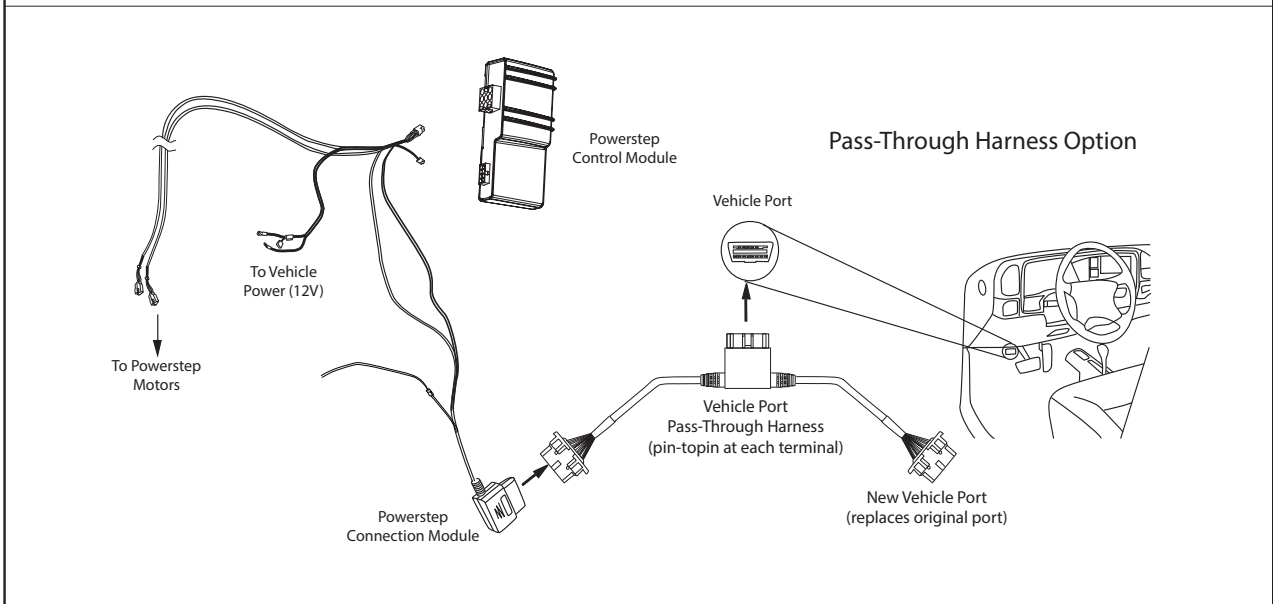
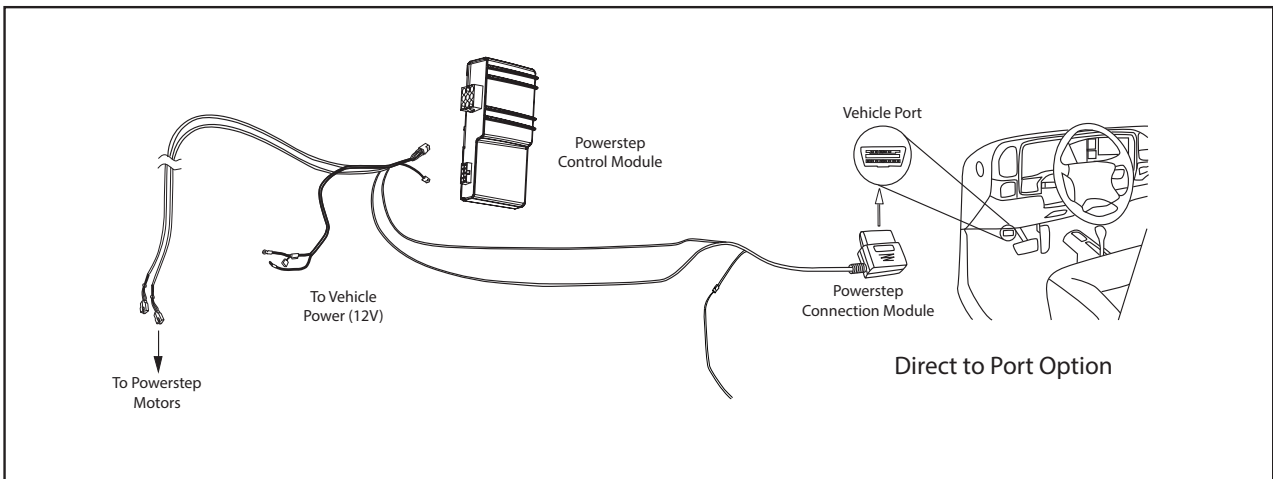
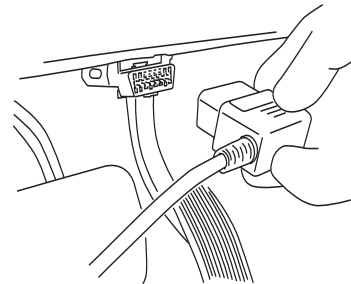

On driver side, run Wire Harness leg down and along underside of the vehicle floor and frame to front Drive Linkage. Connect harness to motor and secure harness with tie wraps. Route remainder of wire harness towards rear linkage assembly for LED lights. Repeat step on passenger side.

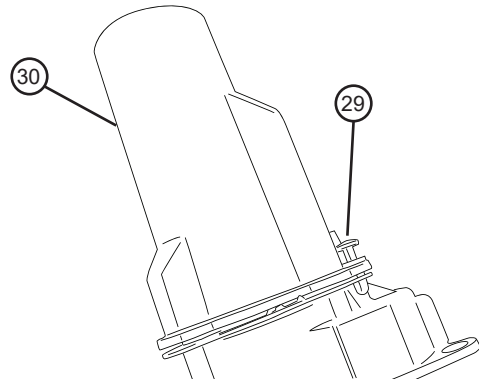
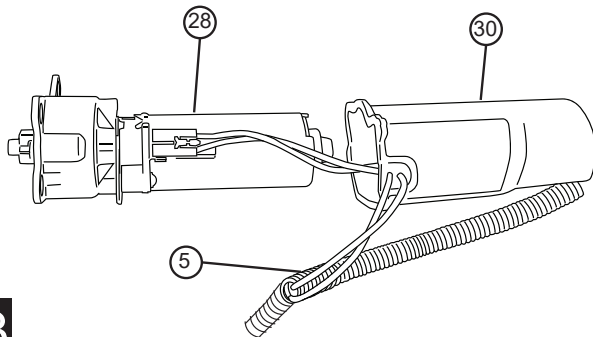

23

Affix LED lamp (24) to Light bracket (25) on rail. Slide bracket into desired position and tighten using 5/32" Allen key.

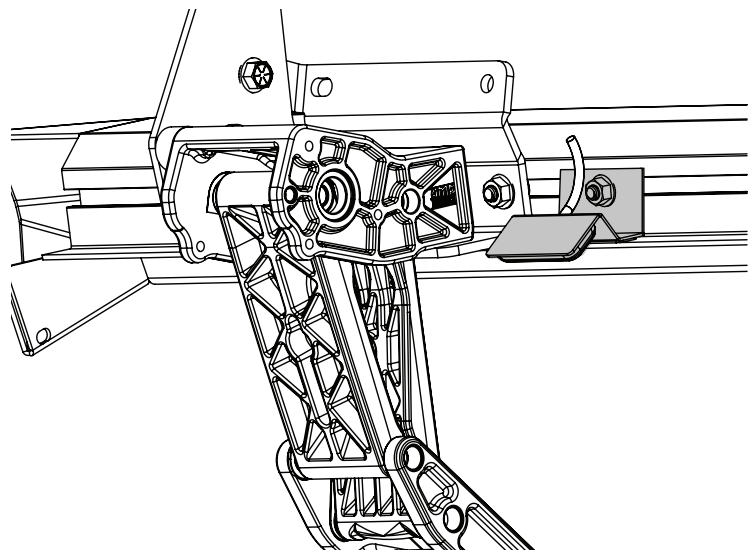
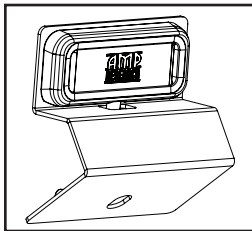

24

Using supplied butt connectors (23), connect the lamp wires. Red to Red, Black to Black. Once Crimped use heat gun to shrink tube. Close and wrap conduit with electrical tape. Secure all loose wires with cable ties (21). Pull lamp wires upward to avoid any wire snagging.

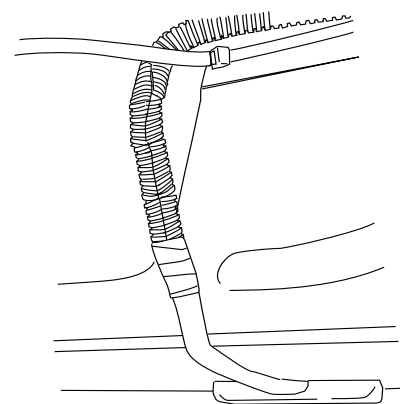
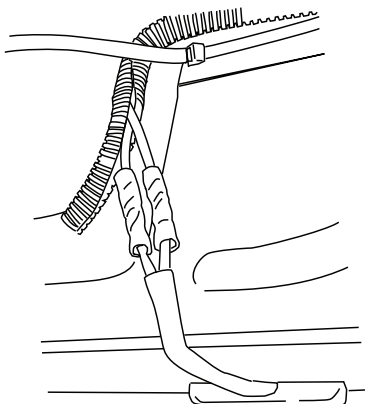

25

Reinstall fuses from Powerstep wire harness. Check that all doors activate the Power Step and the LED Lights work when doors open and close. Reinstall any remaining trim panels.

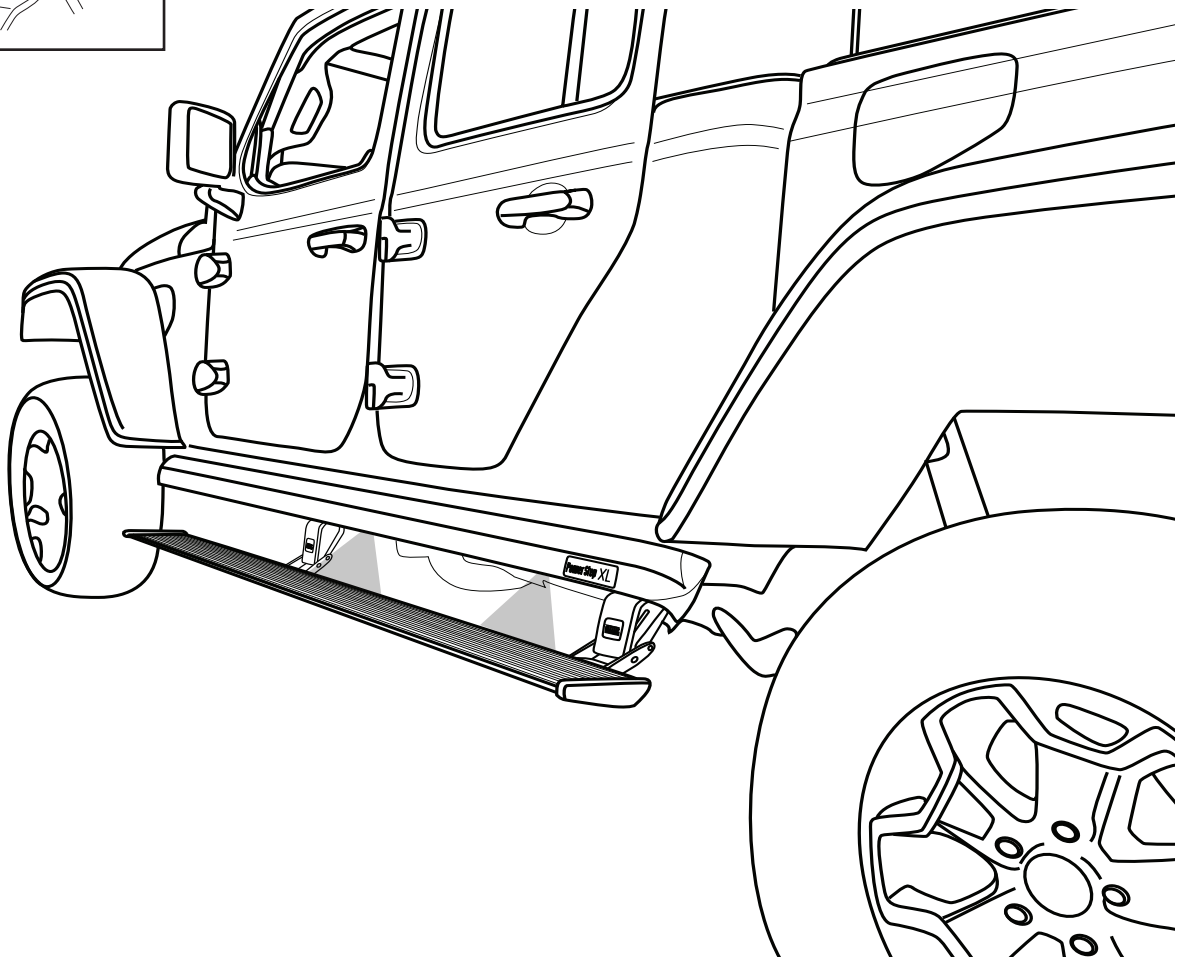
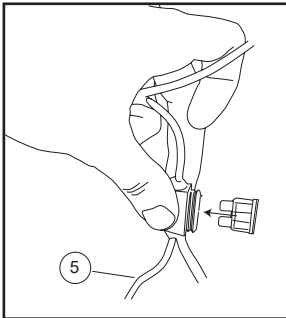

FINAL SYSTEM CHECK

Check that all doors activate the PowerStep and the LED lights work when doors open and close.

NORMAL OPERATION: When the doors open, PowerStep automatically deploys from under the vehicle. When the doors are closed, PowerStep will automatically return to the stowed/retracted position. **Note that there is a 2-second delay before the PowerStep returns to the stowed/retracted position.**

CORRECT OPERATION OF LIGHTS: All four lamps will illuminate upon opening any door of vehicle. Lamps will stay on until restowing of both Power Steps or until 5 minutes has expired with the doors open. When the lights timeout after 5 minutes, they can be reilluminated by closing and opening any door of vehicle.

AMP **RESEARCH** **Power Step**™

AMERICAN DESIGNED, ENGINEERED AND MANUFACTURED.

Thank you for your recent AMP Research Purchase.

REGISTER YOUR PRODUCT TODAY FOR FASTER SERVICE & PRODUCT UPDATES

Please visit:

www.amp-research.com/productregistration
or scan the QR Code



Product Registration Benefits:

- Ensure we have your purchase receipt and product info in our system which is required for warranty
- Faster and easier access to customer service and tech support in the unlikely event you need warranty or product support
- Registration helps us keep you up to date on product information and offers

To view other Amp Research products that may be offered for your vehicle.

Please visit: www.amp-research.com

Rev 01.05.21

POWER-DEPLOYABLE RUNNING BOARDS OPERATION: AMP Research PowerStep running boards automatically move when the doors are opened to assist entering and exiting the vehicle.

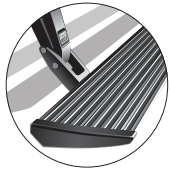

Automatic power deploy:

The running boards will extend down and out when the doors are opened.

Automatic power stow:

The running boards will return to the stowed position when the doors are closed. There will be a 2-second delay before the running boards move to the stowed position.

Automatic stop:

If an object is in the way of the moving running board, the running board will automatically stop. To reset, clear any obstruction, then simply open and close the door to resume normal operation.



Manually set in the deployed (OUT) position for access to the roof:

The running boards can be manually set in the deployed position by firmly holding the step down with your foot while at the same time closing the door. To resume normal operation, open and close the door.

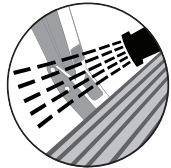

Maintenance: In adverse conditions, debris such as mud, dirt, and salt may become trapped in the running board mechanism, possibly leading to unwanted noise. If this occurs, manually set the running boards to the deployed position and flush the front and rear hinge arms with a high-pressure car wash wand.

Avoid spraying the motors directly. After washing, apply silicone spray lubricant to the hinge pivot pins. Do not apply silicone, wax or protectants like Armor All® to the running board stepping surface.

Caution! Keep hands away when the running board is in motion.

5-YEAR LIMITED WARRANTY

AMP RESEARCH warrants this product to be free from defects in material and workmanship for FIVE (5) YEARS FROM DATE OF PURCHASE, provided there has been normal use and proper maintenance. This warranty applies to the original purchaser only. All remedies under this warranty are limited to the repair replacement of the product itself, or the repair or replacement of any component part thereof, found by the factory to be defective within the time period specified. The decision to repair or replace is wholly within the discretion of the manufacturer.

This warranty specifically excludes labor. If you have a warranty claim, first you must call our factory at the number below for instructions. You must retain proof of purchase and submit a copy with any items returned for warranty work. Upon completion of warranty work, if any, we will return the repaired or replaced item or items to you freight prepaid. Damage to our products caused by accidents, fire, vandalism, negligence, misinstallation, misuse, Acts of God, or by defective parts not manufactured by us, is not covered under this warranty.

ANY IMPLIED WARRANTIES OF MERCHANTABILITY AND/OR FITNESS FOR A PARTICULAR PURPOSE CREATED HEREBY ARE LIMITED IN DURATION TO THE SAME DURATION AND SCOPE AS THE EXPRESS WRITTEN WARRANTY. OUR COMPANY SHALL NOT BE LIABLE FOR ANY INCIDENTAL OR CONSEQUENTIAL DAMAGE.

Some states do not allow limitations on how long an implied warranty lasts, or the exclusion or limitation of incidental or consequential damages, so the above limitations or exclusions may not apply to you. This warranty gives you specific legal rights, and you may also have other rights that vary from state to state.

FOR WARRANTY ISSUES WITH THIS PRODUCT PLEASE CALL AMP RESEARCH TECH SUPPORT 1-888-983-2204

WARNING

Be sure to read and precisely follow the provided instructions when installing this product. Failure to do so could place the vehicle occupants in a potentially dangerous situation. After installing or reinstalling, re-check to insure that the product is properly installed.



The material that your product is made from can be recycled. Please also consider recycling the packaging that your product came in.

