

APPLICATION

Ford F150
(Fits all Beds)

MODEL YEAR

2015 - 2024

PART NUMBER

75412-01A

USED ON ALL BEDS

USED ON 6.5 and 8ft beds ONLY

For 2021 models you'll need a utility knife or hack saw

Preview of final assembly... Driver Side and Passenger Side will be assembled differently, resulting in mirror images of one another.

Driver Side

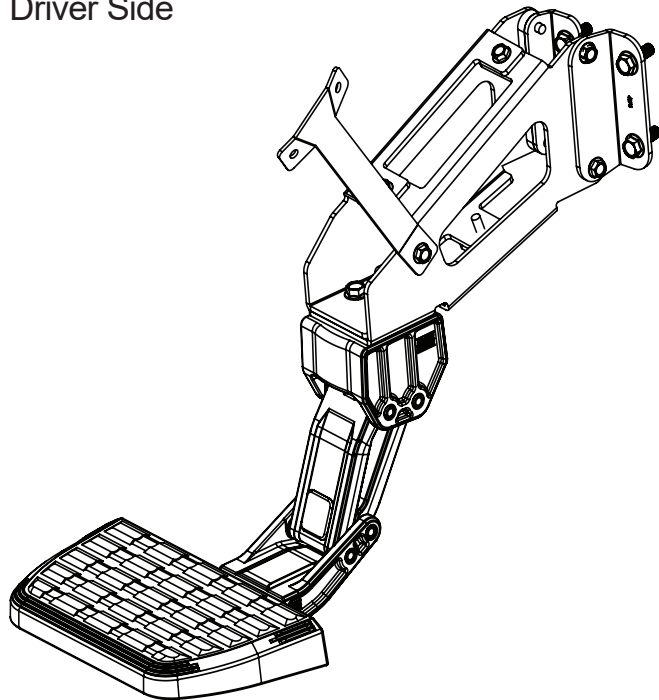

Passenger Side

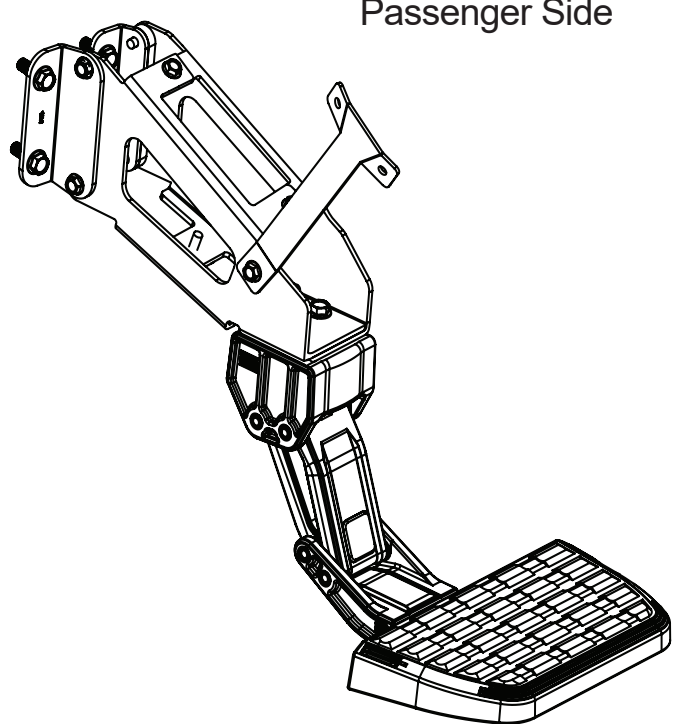

1

REALTRUCK TECH SUPPORT 1-888-983-2204 (Press 2) Monday - Friday, 8:00 AM - 5:00 PM EST

Designed and manufactured by AMP Research® • Made in Mexico
Patent Protected. Please see our product site for applicable patents. www.realtruck.com/b/amp-research/
© 2024 AMP Research • Three-year limited warranty. • Professional installation is recommended.

Step 2 through 4 are ONLY for 2021-2024 Models. All other model years, skip to step 5.

On 2021-2024 Models only.

Remove trim piece (shown with arrow) by first removing 3 fasteners with 7mm socket and then carefully releasing from remaining clip fastener.

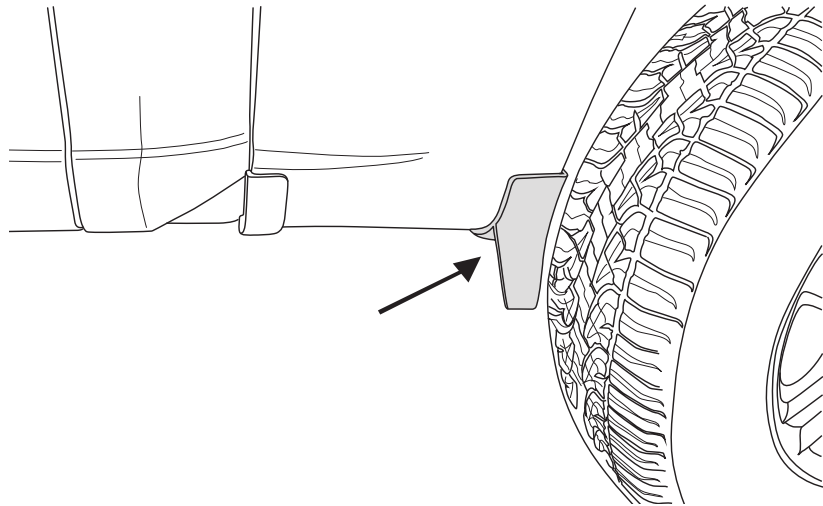

2

On 2021-2024 Models only.

Mark trim line as shown. Cut to trim line and clean up edges. Additional trimming/shaping is optional to more closely match the original shape of the trim piece. Band saw recommended for trimming but other tools can be used, ie. utility knife, hack saw, etc.

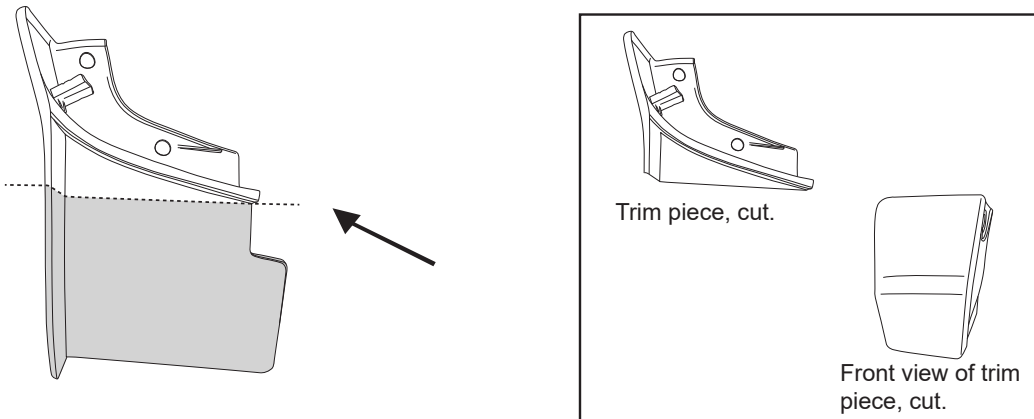

3

On 2021-2024 Models only.

Reinstall trim piece back on to truck by fastening it to the clip than install the 3 fastners using a 7 mm socket to snug fit.

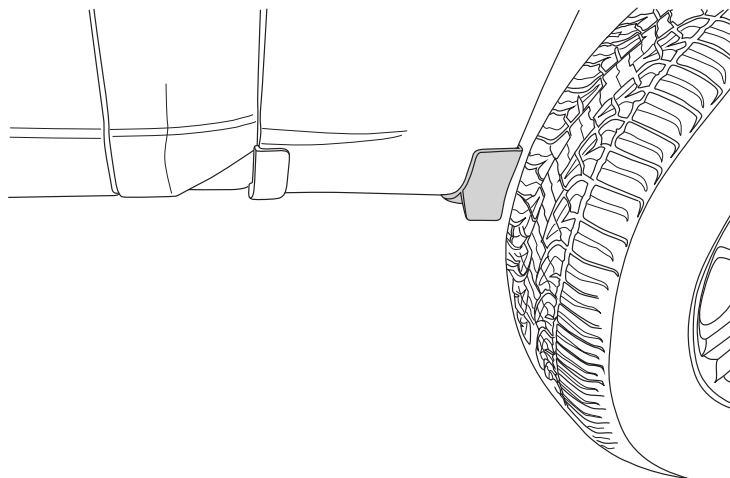

4

Main Bracket Assembly...Bolt Left Main Bracket (3) over Right Main Bracket (4) and hand tighten all three (9) Small M8 Bolts (2 on top, 1 on bottom).

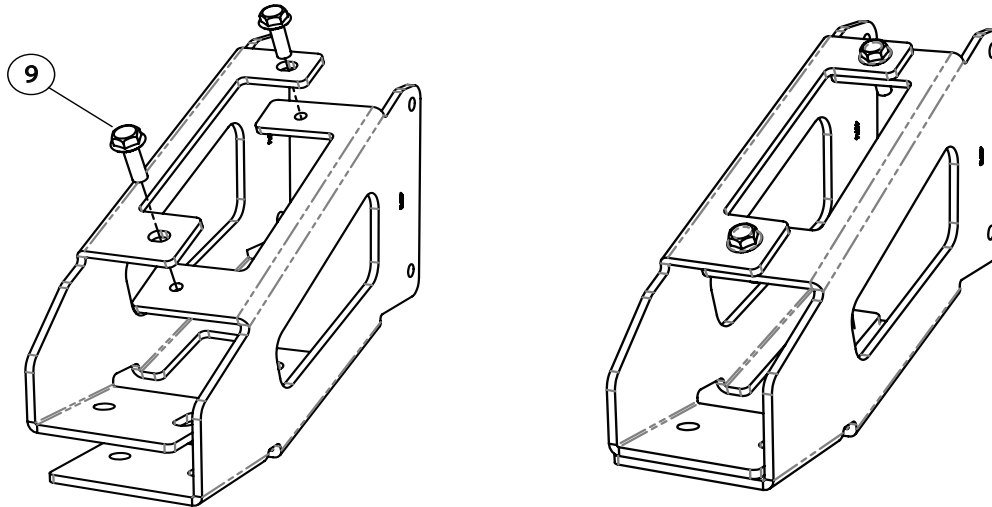

5

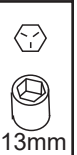

For 5.5ft Beds, L Bracket Assembly for 5.5ft bed... On Driver Side, bolt Left Main Bracket (3) to L Bracket (6) and bolt Right Main Bracket (4) to L Bracket (5) using 4 M8 bolts (8). Tighten to 20 ft lbs. For Passenger Side, The L-Bracket will swap positions and orientation.

Note: Orientation of Bolt Circled Below

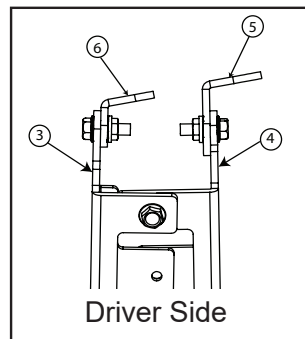
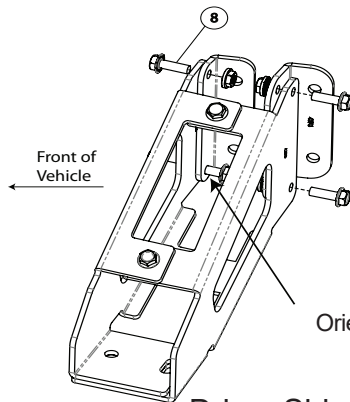

Driver Side

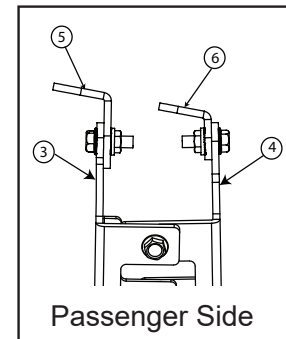

Passenger Side

Orient Bolt as pictured to allow for clearance and ease of installation.

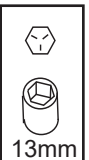

6a

Driver Side shown

L Bracket Assembly for 6ft & 8ft beds... On Driver Side, bolt spacer in between Left Main Bracket (3) and L Bracket (6) using longer M8 bolts (18). Bolt Right Main Bracket (4) to L Bracket (5) using 2 M8 bolts. Tighten to 20 ft lbs.

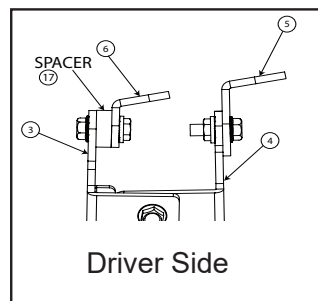
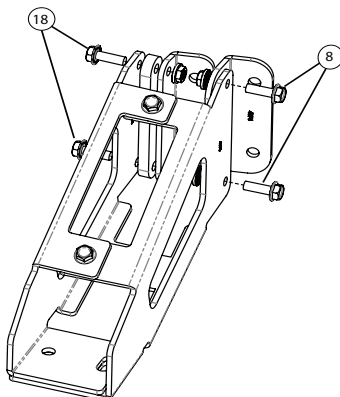

Driver Side

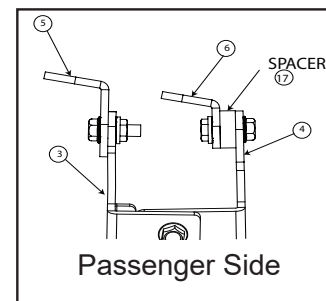

Passenger Side

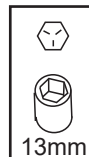

6b

Driver Side shown

Assemble bracket to linkage assembly using M10 Bolts. Tighten just enough to be able to swivel assembly back and forth.

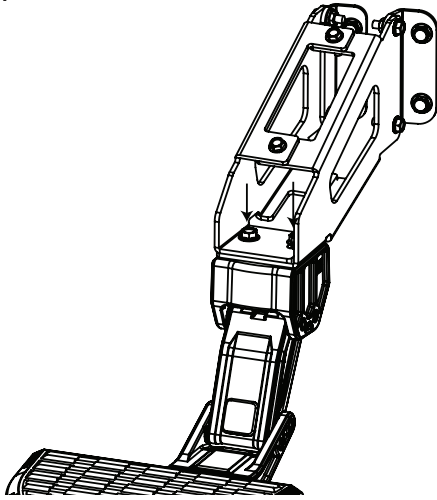

7

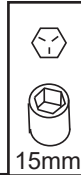

15mm

Insert four U clips into cutouts in frame. *Be careful not to drop U clips in frame.*

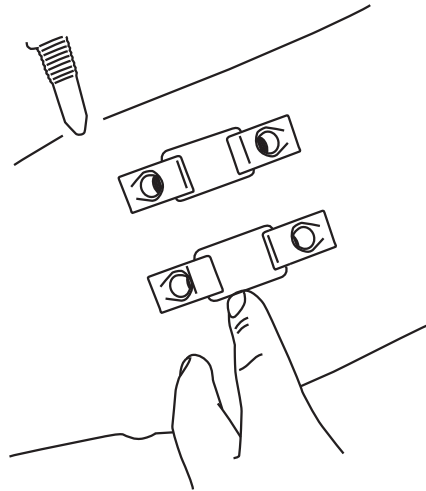

8

Set assembly in place and tighten 4 M10 bolts (10) to the frame using a 15mm socket. Torque bolts to 33 ft-lbs.

Note: Extension may be needed to access bolts.

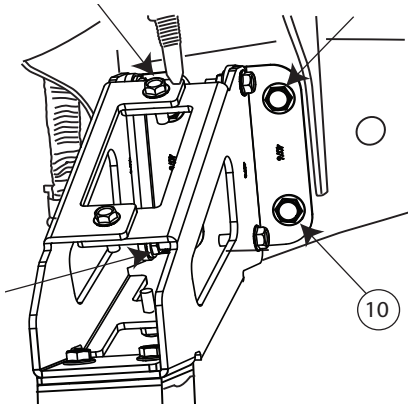

9

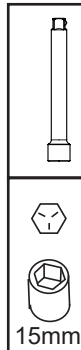

15mm

When assembly is secured to frame, proceed to tightening 3 M8 bolts shown below.

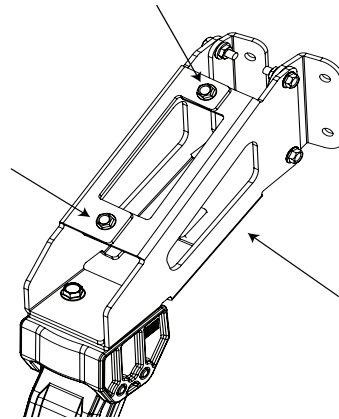

10

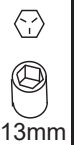

13mm

Locate holes on inner fender well and bracket and install support bracket on the inside of front of fender as shown below.

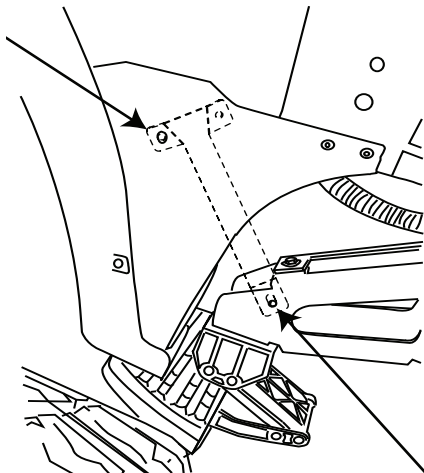

11

Attach support bracket to through hole with supplied M8 bolt and nut. Tighten to 33ftlbs. Orientation is shown below for driver side, mirror for passenger side. **Use the two supplied plastic washers to isolate the bracket and sheet metal to avoid possible corrosion.**

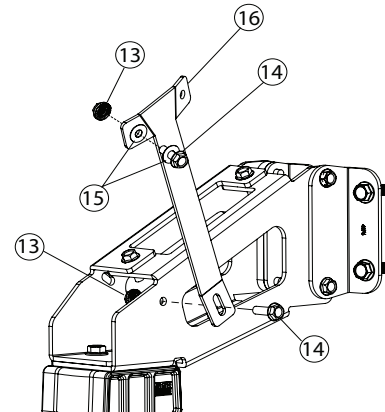

12

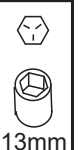

13mm

Once support bracket is secured, torque bolts to 33ft. lbs as shown below.
Tighten M8 Bolts from step 2 to 25 ft lbs.

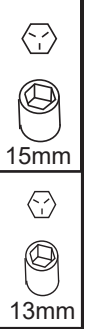
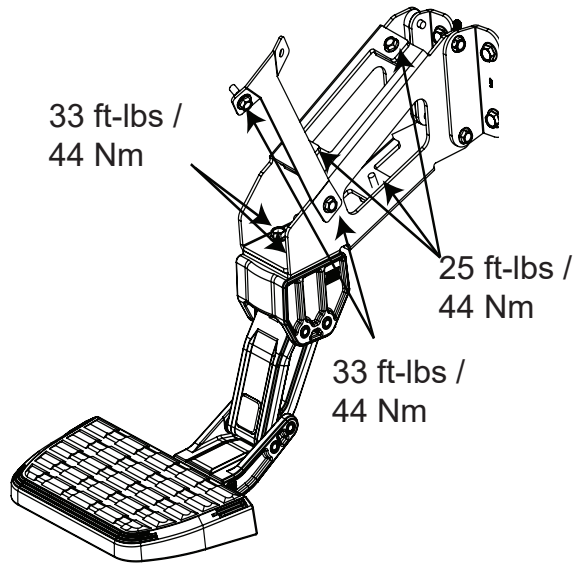

13

Offset the step pad forward and secure using provided PT Screws. Tighten to 5 ft-lbs using T25 torx bit.
Note: Driver side shown

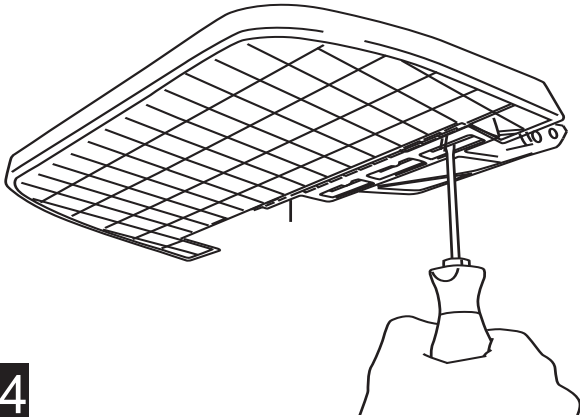

14

Adjust step pad to be in line with fender and torque bolts from Step 5 to 20ft-lbs.

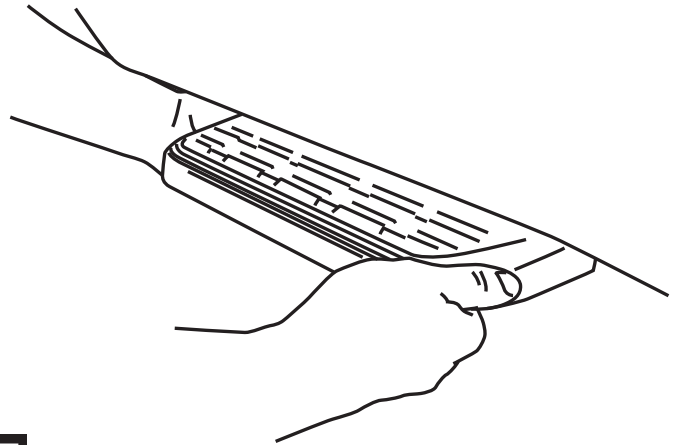

15

To deploy the step, press down using your foot on the outside edge of the step pad.
Note: 2021 Model shown below.

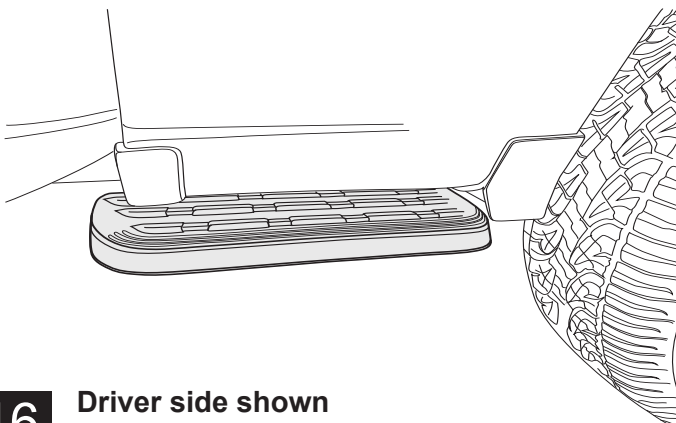

16

Driver side shown

To retract, gently kick up on the underside of the step pad.
Note: 2021 Model shown below.

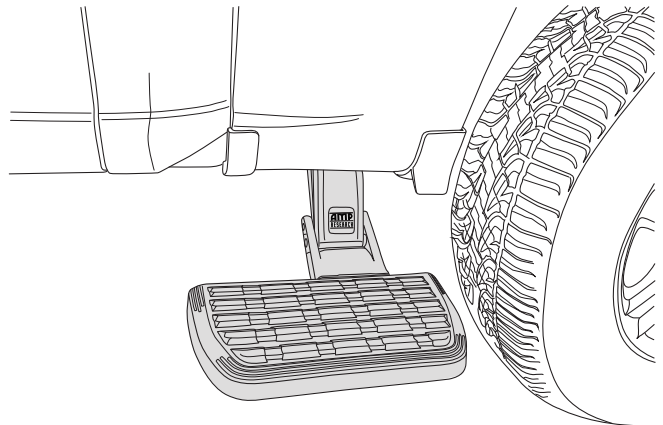

17

Driver side shown

Thank you for your recent Realtruck Purchase.

**REGISTER YOUR PRODUCT TODAY FOR
FASTER SERVICE & PRODUCT UPDATES**

Please visit:

<https://realtruck.com/warranty-registration/>
or scan the QR Code



Product Registration Benefits:

- Ensure we have your purchase receipt and product info in our system which is required for warranty.
- Faster and easier access to customer service and tech support in the unlikely event you need warranty or product support.
- Registration helps us keep you up to date on product information and offers.

To view other Realtruck products that may be offered for your vehicle.

Please visit: www.realtruck.com

**Congratulations on the purchase of your
AMP Research BedStep®**

Here's what you should know...

OPERATION

- The AMP Research BedStep® is foot operated and deploys and retracts with a nudge of your foot.
- To deploy, press down using your left foot, on the forward outside corner of the step pad.
- To retract, gently kick the underside of the step pad.
- Max Load Capacity: 300lbs.
- Always use appropriate hand holds when stepping up to or down from your truck's cargo bed.

MAINTENANCE TIPS

The step pad surface and linkage arms can be washed with mild soap and water using a soft brush or sponge to dislodge any mud, dirt or accumulated road grime. Rinse with fresh water.

To prevent slipping, avoid applying waxes, lubricants or protectants like Armor All® to the step surface.

ATTENTION!

BEDSTEP SHOULD ALWAYS BE STOWED IN THE RETRACTED POSITION WHEN DRIVING.

LIMITED WARRANTY

REALTRUCK warrants product to be free from defects in material and workmanship, for terms specified below, provided there has been normal use and proper maintenance. All remedies under this warranty are limited to the repair or replacement of any item found by the factory to be defective within the time period specified.

If you have a warranty claim, first you must call our factory at the number below for instructions. You must retain proof of purchase and submit a copy with any items returned for warranty work. Upon completion of warranty work, if any, we will return the repaired or replaced item or items to you freight prepaid. Damage to our products caused by accidents, fire, vandalism, negligence, misinstallation, misuse, acts by mother nature, or by defective parts not manufactured by us, is not covered under this warranty.

THE WARRANTY TIME PERIOD IS AS FOLLOWS: THREE YEARS FROM DATE OF PURCHASE.

ANY IMPLIED WARRANTIES OF MERCHANTABILITY AND/OR FITNESS FOR A PARTICULAR PURPOSE CREATED HEREBY ARE LIMITED IN DURATION TO THE SAME DURATION AND SCOPE AS THE EXPRESS WRITTEN WARRANTY. OUR COMPANY SHALL NOT BE LIABLE FOR ANY INCIDENTAL OR CONSEQUENTIAL DAMAGE.

Some states do not allow limitations on how long an implied warranty lasts, or the exclusion or limitation of incidental or consequential damages, so the above limitations or exclusions may not apply to you. This warranty gives you specific legal rights, and you may also have other rights that vary from state to state.

FOR WARRANTY ISSUES WITH THIS PRODUCT PLEASE CALL REALTRUCK CUSTOMER SERVICE 1-888-983-2204

WARNING

Be sure to read and precisely follow the provided instructions when installing this product. Failure to do so could place the vehicle occupants in a potentially dangerous situation. After installing or reinstalling, re-check to insure that the product is properly installed.