

APPLICATION
Toyota Hilux (4 Door Pickup)

MODEL YR
2015-2018

PART #
75164-01A

INSTALLATION GUIDE

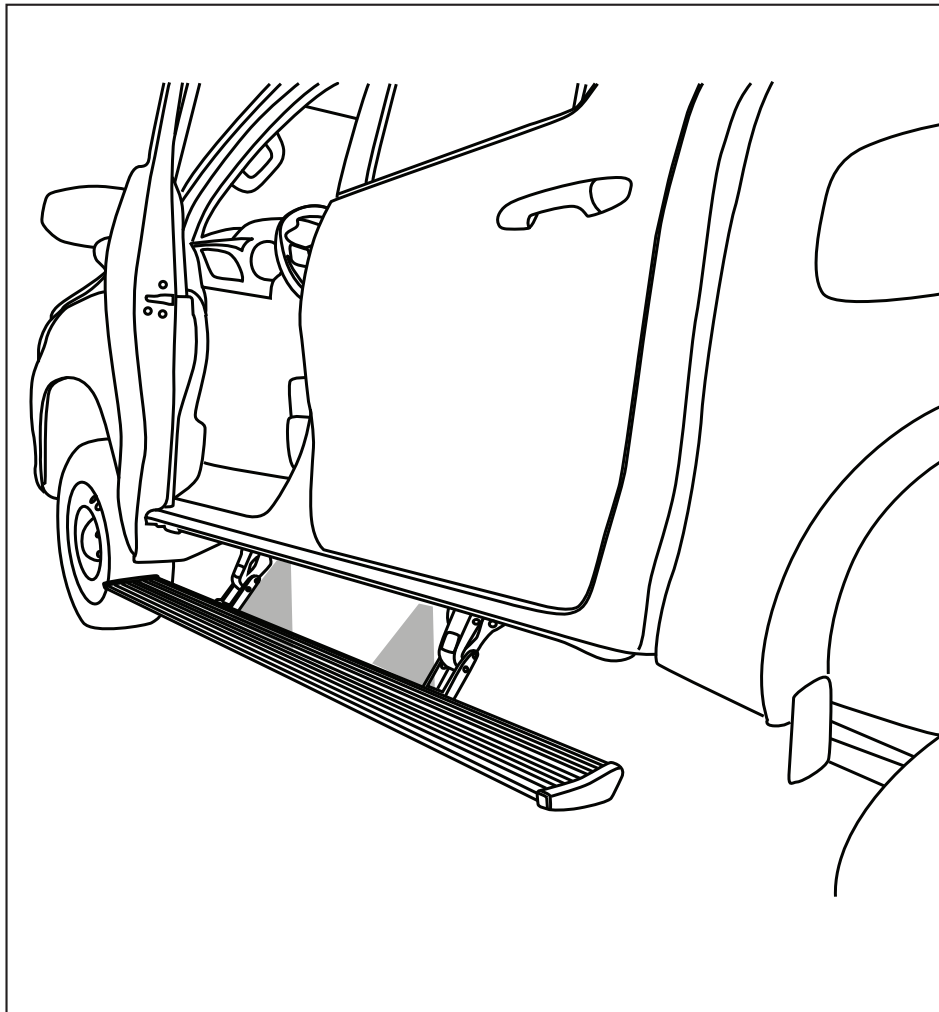

INSTALLATION TIME

3-5 Hours

Professional installation recommended

SKILL LEVEL



3= Experienced

TOOLS REQUIRED

- Safety goggles
- Measuring tape
- 19 mm socket
- 10 mm socket
- 12 mm socket
- Ratchet wrench and extension
- Pliers
- Wire crimpers
- Wire stripper / cutter
- 3/16" hex key wrench (allen wrench)
- 4mm hex key wrench (allen wrench)
- Electrical tape
- Weather proof caulking (silicone sealer)
- 9/32 drill bit
- Drill

WARRANTY

5-Year Limited Warranty

REALTRUCK TECH SUPPORT 1-888-983-2204 (Press 2) Monday - Friday, 8:00 AM - 5:00 PM EST

Designed and manufactured by RealTruck AMP Research® • Made in Mexico
Patent Protected. Please see our product site for applicable patents. www.realtruck.com/b/amp-research/
© RealTruck Group, Inc., 2024 • Three-year limited warranty. • Professional installation is recommended.

PARTS LIST AND HARDWARE IDENTIFICATION

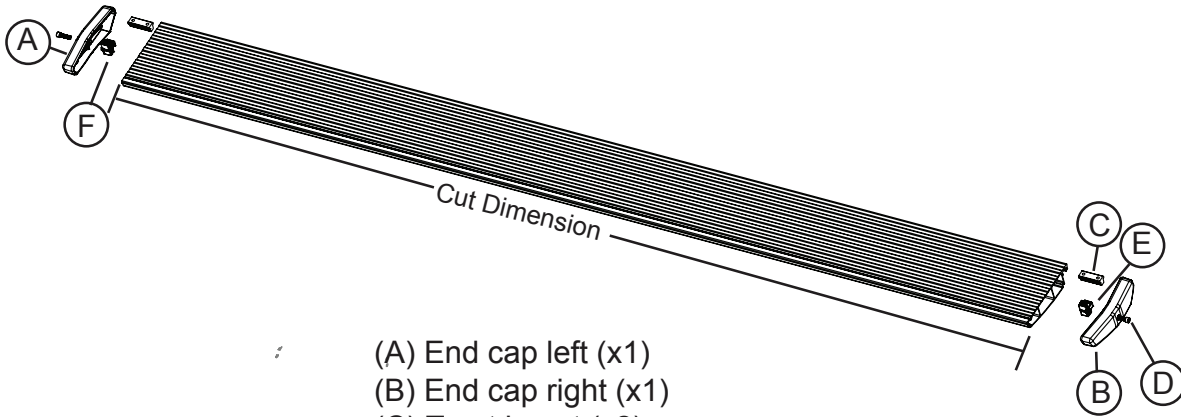

- (A) End cap left (x1)
- (B) End cap right (x1)
- (C) T-nut insert (x2)
- (D) Socket cap screw (x2)
- (E) End cap wedge right (x1)
- (F) End cap wedge left (x1)

1 x2

Running board assembly

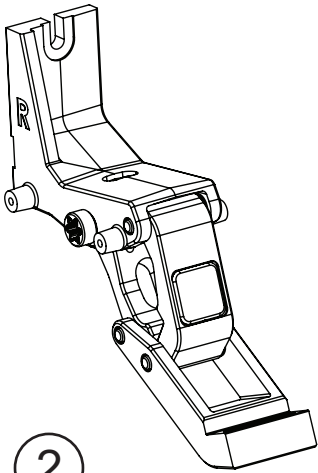

2

Driver Motor
Linkage Assembly
(Rear)

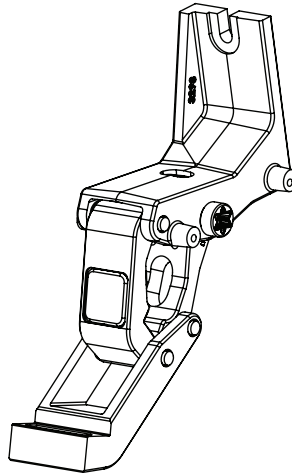

3

Passenger Motor
Linkage Assembly
(Rear)

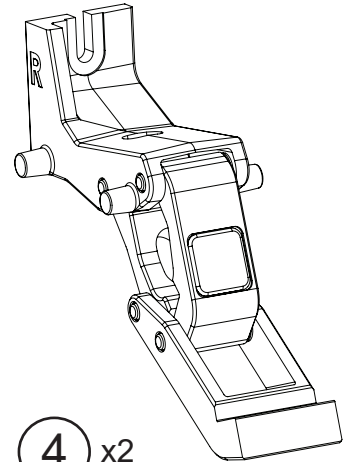

4 x2

Idler Linkage
Assembly
(Front)

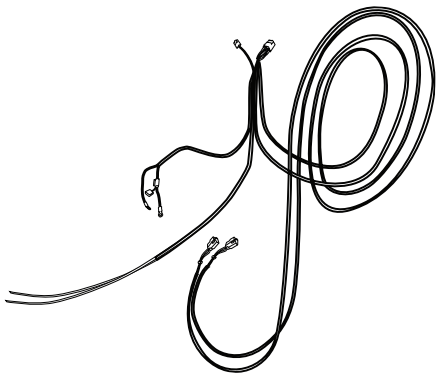

5

Wire Harness

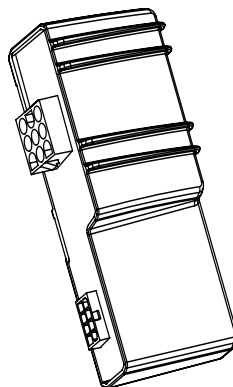

6

Controller STA

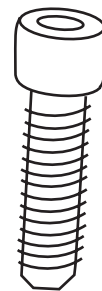

7 x8

Socket Cap Screw

PARTS LIST AND HARDWARE IDENTIFICATION

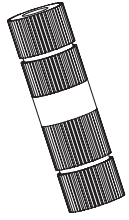

8 x4
Posi-Tap™ (Red/Grey)

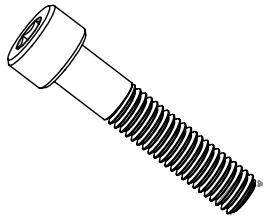

9 x4
Flat Head Cap Screw



10 x6
Cinch Fastener

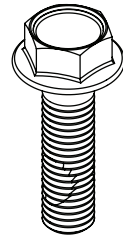

11 x8
Flange Head Bolt

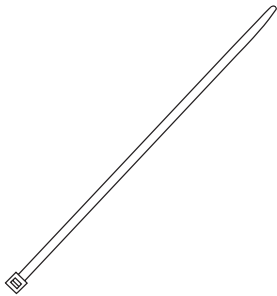

12 x25
Cable Tie 7"

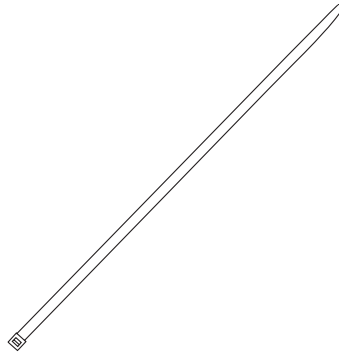

13 x2
Cable Tie 11"

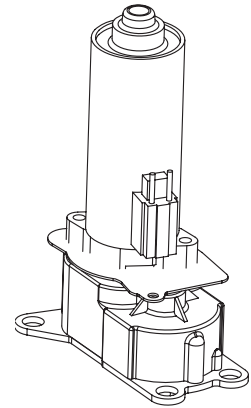

14 x2
Motor

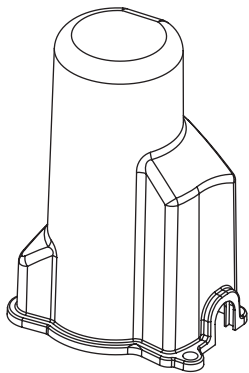

15 x2
Motor Cover

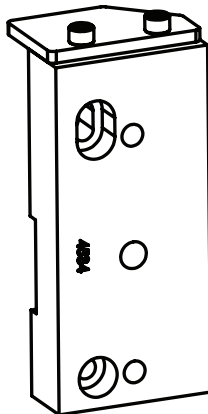

16 x2
Frame Mount Extrusion
(Rear)

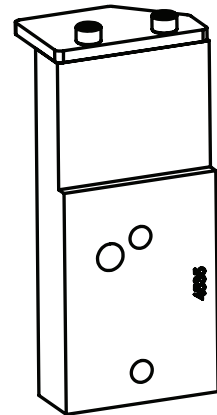

17 x2
Frame Mount Extrusion
(Front)

PARTS LIST AND HARDWARE IDENTIFICATION



18 x4
Grommet

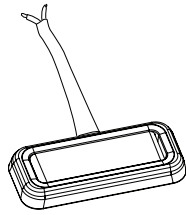

19 x4
LED Lamp

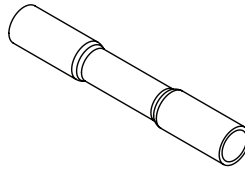

20 x8
Butt Connector

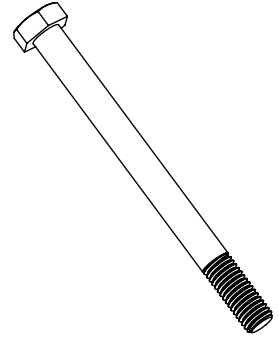

21 x2
M12 Hex Bolt

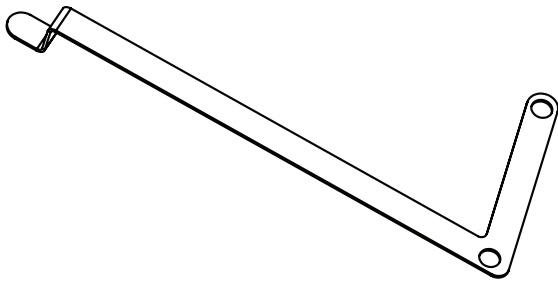

22
Frame mount Plate (Driver)

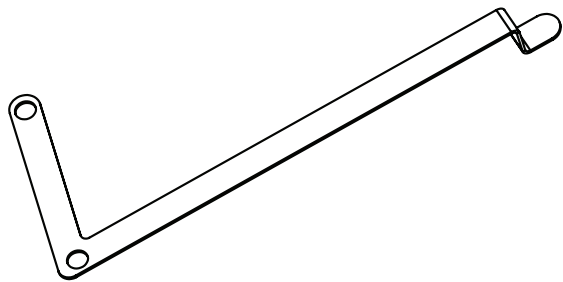

23
Frame mount Plate (Passenger)



24 x4
U Nut

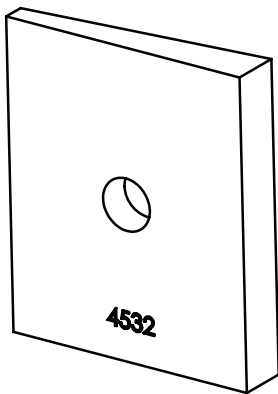

25 x2
Wedge Shim

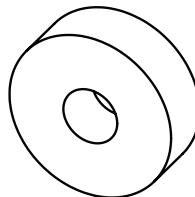

26
Spacer



27 x2
Lock washer

Remove brake line support tab to allow access through frame. Attach front mounting block using longer M12 bolt with wedge shim. Pull block down to align top plate with top edge of frame. Tighten and torque to 12 ft-lbs.

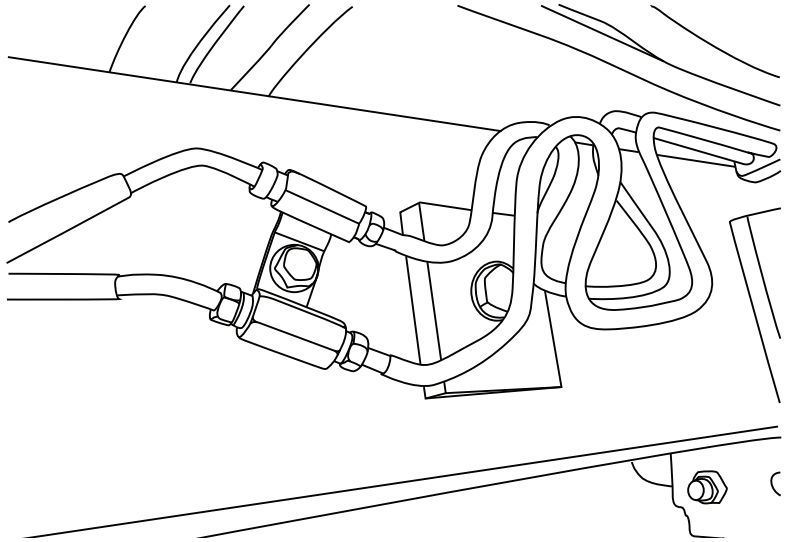

1

Use supplied spacer to stand brake line bracket off frame. Tighten and torque to 12 ft-lbs.

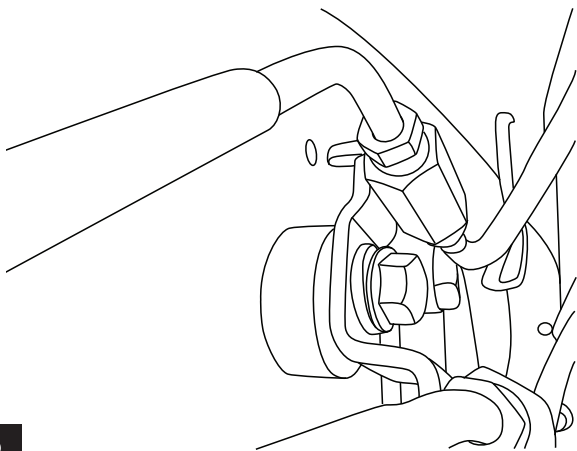

2

Front Idler Linkage: Pre thread upper M10 flange head bolt onto frame mount. Slide linkage into position and thread in lower flange head bolt.

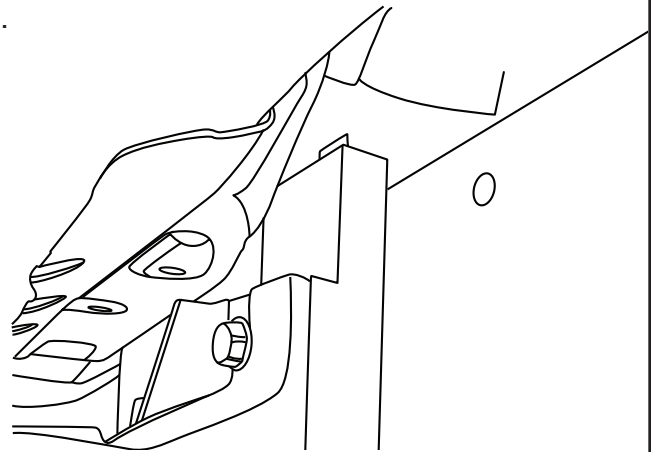

3

Rear Drive Linkage: Note orientation of U clips. Driver side shown. Insert U nut carrier into frame as shown and locate to 2 vertical holes in rear section of frame. Set rear block into place and use provided M8 Socket cap screws to attach block to frame. Pull block down to align top plate with top edge of frame. Torque bolts to 16 ft-lbs.

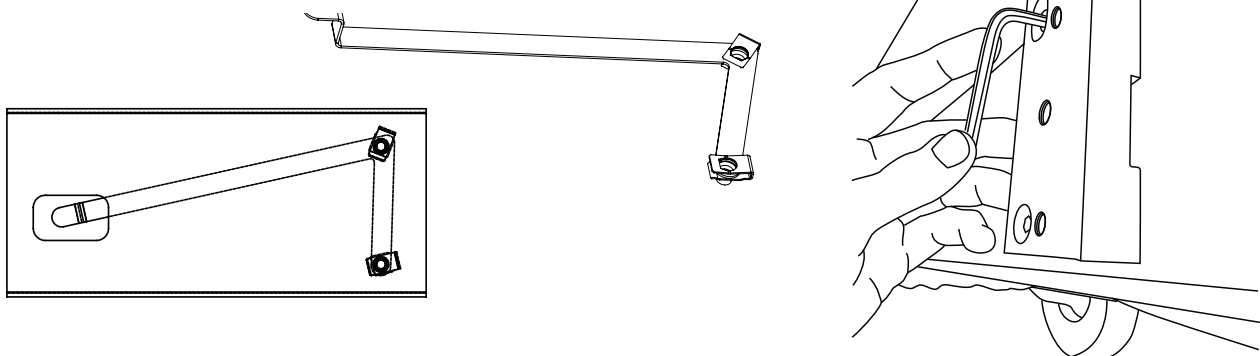

4

Pre thread upper M10 flange head bolt onto frame mount. Slide linkage into position and thread in lower flange head bolt. Motor faces front of vehicle.

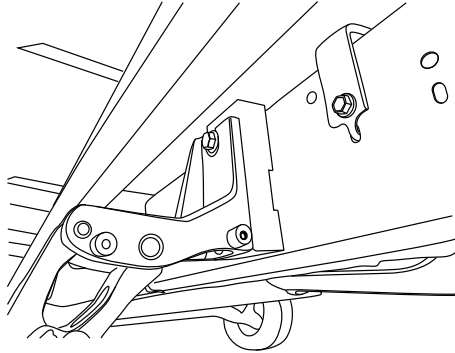

5

Slide mounting T nut into position. Slide the board back so that the rear endcap of the board is approx. 17" from the lower mount as shown.

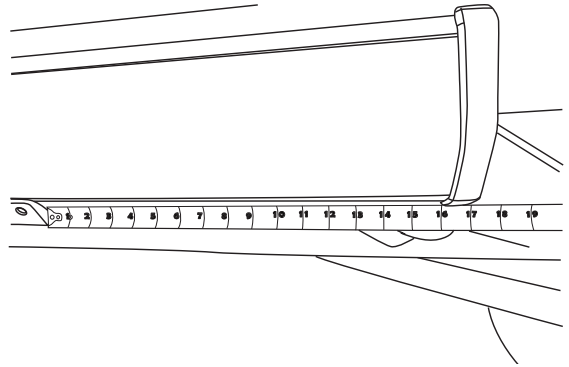

6

Once running board is attached to lower mount tighten linkages at front and rear. Tighten front linkage and check for bind in the system. Steps should deploy under own weight.

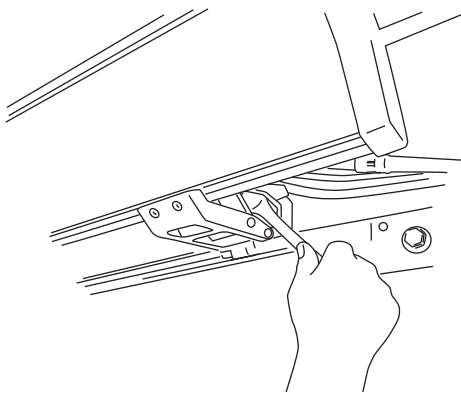

7

Attach motor onto Motor Linkage Assembly using two M6x16 flat head screws on both drive and passenger sides

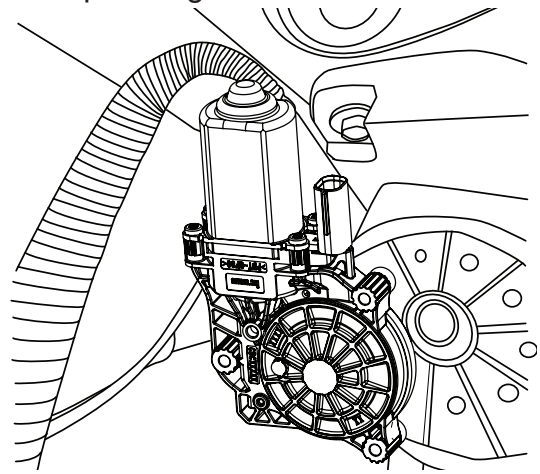

8

Remove fuse.

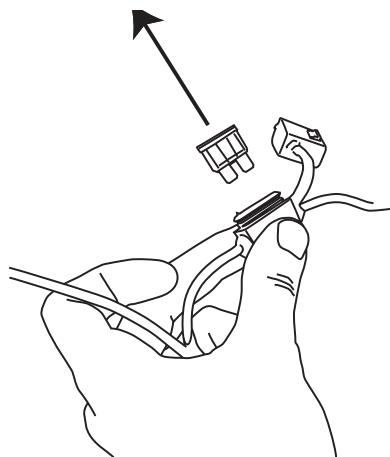

9

Secure controller to factory wire loom using supplied 11" wire ties. Connect Red fused wire to stud on battery positive terminal. Connect Black wire to ground on inner fender panel.

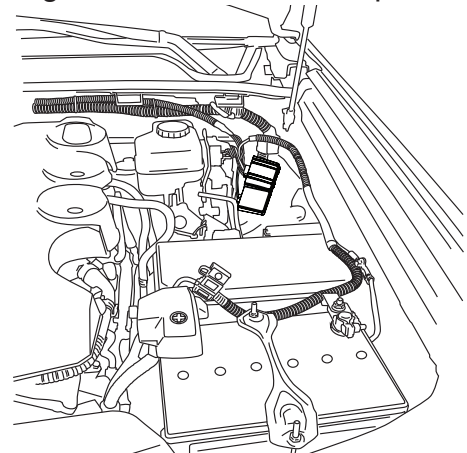

10

Run wire harness as shown outside the frame rails on both sides. Avoid hot, sharp or moving parts! Secure with 7" wire ties.

Note: Run loom with Green/Yellow and Pink/Black Trigger wires down drivers side of vehicle.

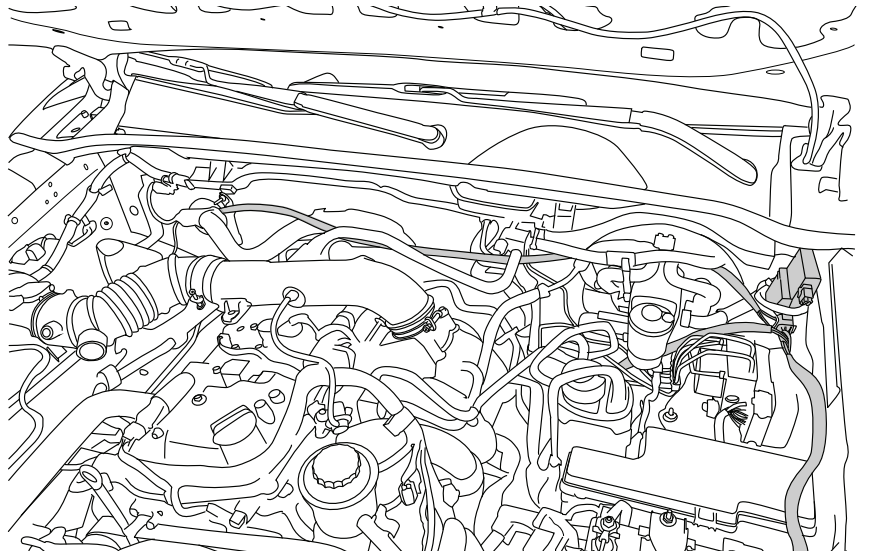

11

Pry up front door sill plates and remove kick panel fasteners and panels on driver and passenger side.

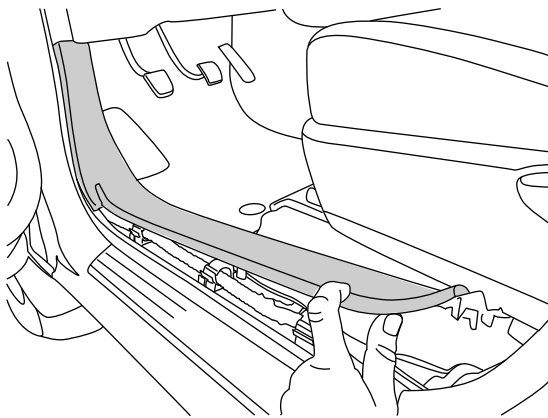

12

Pull up carpet and locate rubber grommet. Slice the grommet and pass trigger wires from under the vehicle and into the cab.

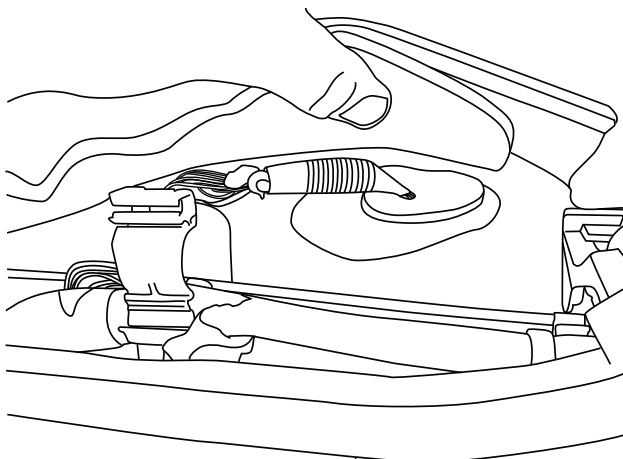

13

Posi-Tap Instructions

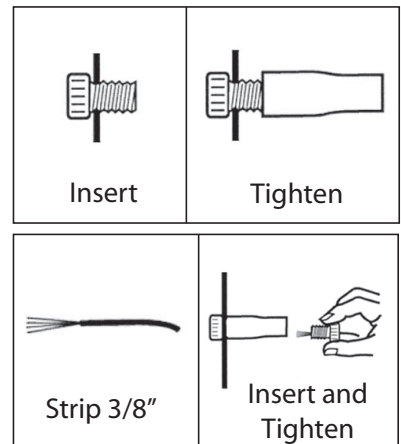

14

15

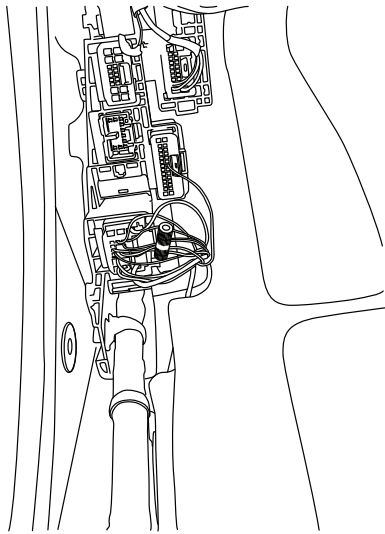

Driver side front: Connect Purple trigger wire to Purple factory door ajar signal wire. Use supplied posi tap.

Driver side rear: Connect Red trigger wire to Red factory door ajar signal wire. Use supplied posi tap.

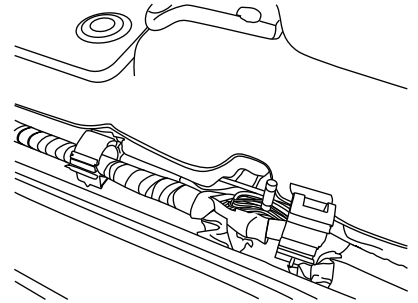
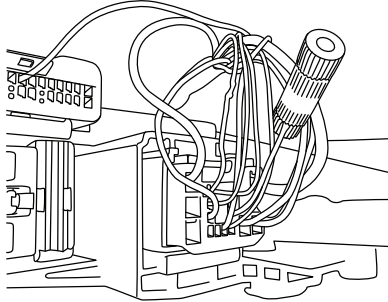

16

Passenger side front: Connect Black trigger wire to Blue factory door ajar signal wire. Use supplied posi tap.

Passenger side rear: Connect Red trigger wire to Red factory door ajar signal wire. Use supplied posi tap.

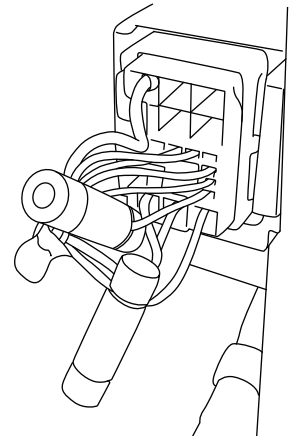
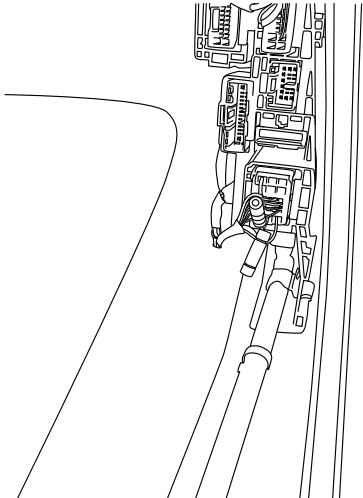

17

Connect Wire Harness to Motor.

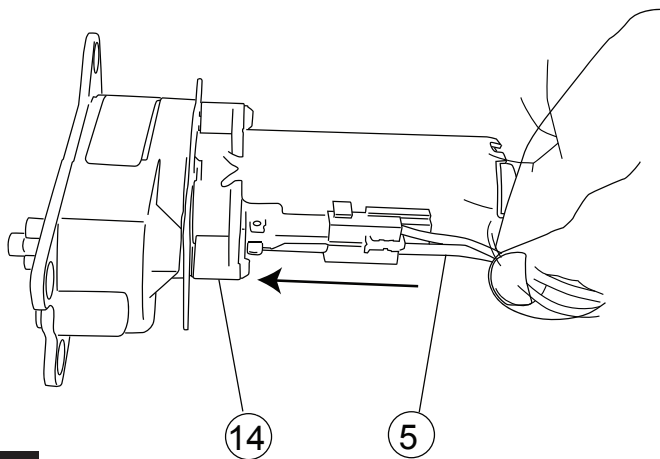

18

Slide rubber grommet on Wire Harness into slot of Motor Cover. Slide Motor Cover over Motor.

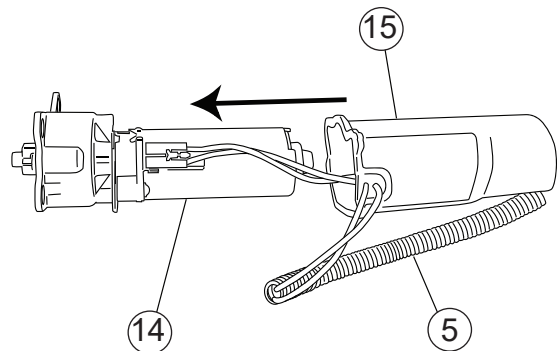

Insert plastic push pin rivets in mounting holes of Motor Cover.

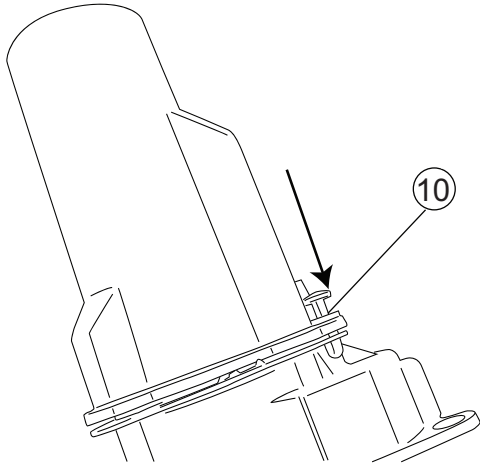

On each side of the vehicle measure from the front edge of door line on the pinch weld to the specified lengths below. Measure at 24" for front LED Light and 53" for rear LED Light.

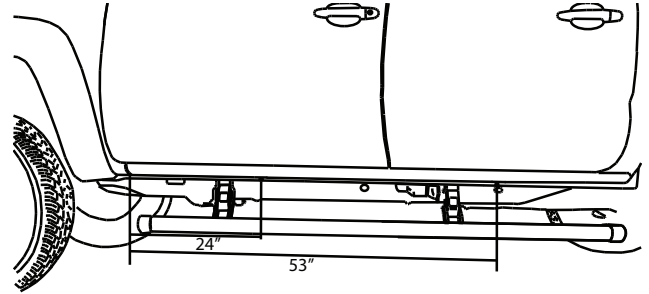

19

20

Drill a 9/32" hole through the pinch weld at marked locations. Deburr all holes.

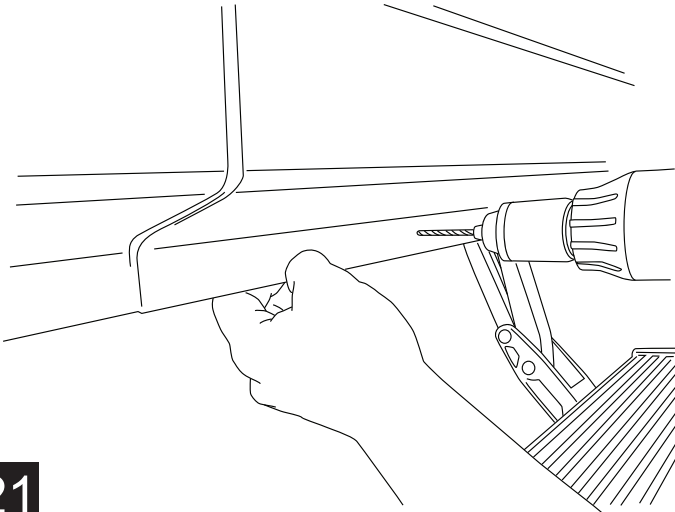

Insert grommet into drilled holes. Insert lamp wires through the grommets. (Silicon lube will help wires slip through grommets.)

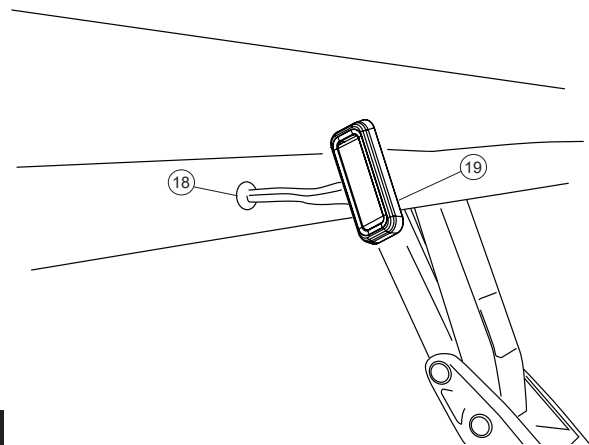

21

22

Affix lamp to rocker panel surface. Make sure lamp is affixed to a flat, clean surface.

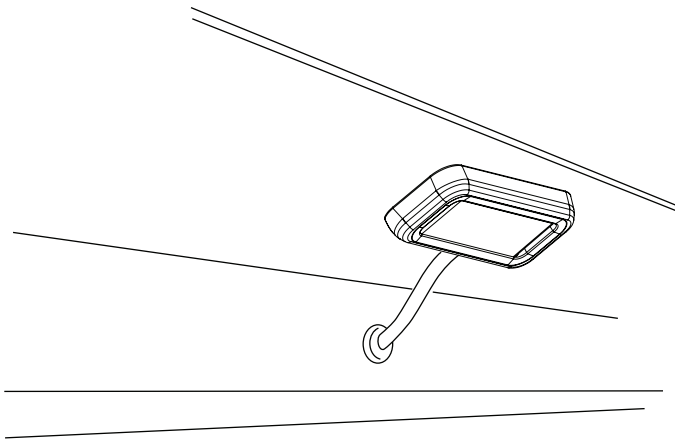

Using supplied butt connectors, connect the lamp wires. Red to Red, Black to Black. Once Crimped use heat gun to shrink tube.

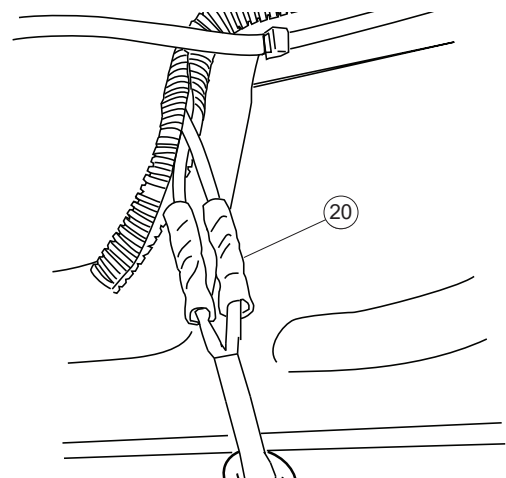

23

Close and wrap with conduit and electrical tape. Secure all loose wires with cable ties, with lamp wires pulled upward to avoid any wire snagging.

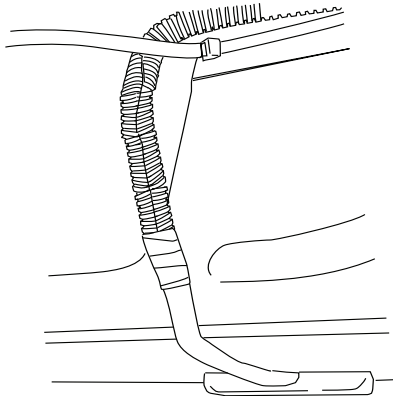

24

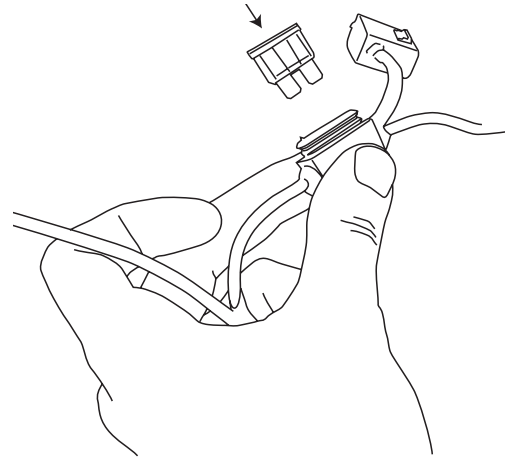

Reinstall fuse.

25

Check that all doors activate the Power Step and the LED Lights work when doors open and close. Reinstall any remaining trim panels.

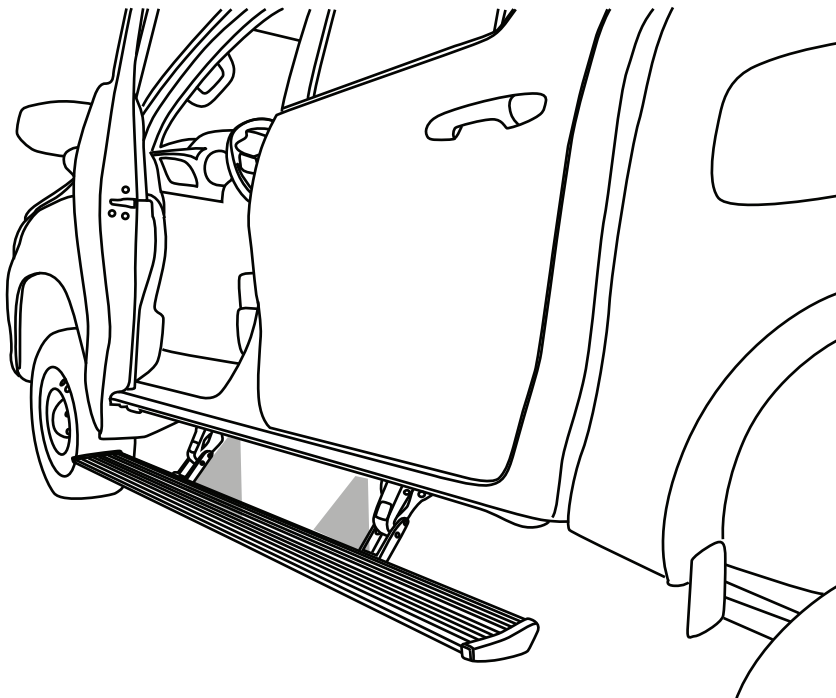

FINAL SYSTEM CHECK

Check that all doors activate the PowerStep and the LED lights work when doors open and close.

NORMAL OPERATION: When the doors open, PowerStep automatically deploys from under the vehicle. When the doors are closed, PowerStep will automatically return to the stowed/retracted position. **Note that there is a 2-second delay before the PowerStep returns to the stowed/retracted position.**

CORRECT OPERATION OF LIGHTS: All four lamps will illuminate upon opening any door of vehicle. Lamps will stay on until restowing of both Power Steps or until 5 minutes has expired with the doors open. When the lights timeout after 5 minutes, they can be reilluminated by closing and opening any door of vehicle.

26



AMERICAN DESIGNED & ENGINEERED

Thank you for your recent RealTruck purchase.

REGISTER YOUR PRODUCT TODAY FOR FASTER SERVICE & PRODUCT UPDATES

Please visit:

<https://realtruck.com/warranty-registration/>
or scan the QR Code



Product Registration Benefits:

- Ensure we have your purchase receipt and product info in our system which is required for warranty.
- Faster and easier access to customer service and tech support in the unlikely event you need warranty or product support.
- Registration helps us keep you up to date on product information and offers.

To view other RealTruck products that may be offered for your vehicle.

Please visit: www.realtruck.com

Rev 05.30.24

Congratulations on your purchase of the genuine RealTruck / AMP Research PowerStep!

Here's what you should know...

POWER-DEPLOYABLE RUNNING BOARDS OPERATION: RealTruck / AMP Research PowerStep running boards automatically move when the doors are opened to assist entering and exiting the vehicle.

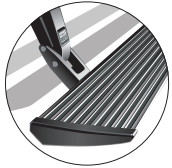

Automatic power deploy:

The running boards will extend down and out when the doors are opened.

Automatic power stow:

The running boards will return to the stowed position when the doors are closed. There will be a 2-second delay before the running boards move to the stowed position.

Automatic stop:

If an object is in the way of the moving running board, the running board will automatically stop. To reset, clear any obstruction, then simply open and close the door to resume normal operation.



Manually set in the deployed (OUT) position for access to the roof:

The running boards can be manually set in the deployed position by firmly holding the step down with your foot while at the same time closing the door. To resume normal operation, open and close the door.

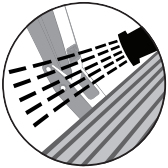

Maintenance: In adverse conditions, debris such as mud, dirt, and salt may become trapped in the running board mechanism, possibly leading to unwanted noise. If this occurs, manually set the running boards to the deployed position and flush the front and rear hinge arms with a high-pressure car wash wand. Avoid spraying the motors directly. After washing, apply silicone spray lubricant to the hinge pivot pins. Do not apply silicone, wax or protectants like Armor All® to the running board stepping surface.

Caution! Keep hands away when the running board is in motion.

5-YEAR LIMITED WARRANTY

RealTruck / AMP RESEARCH warrants this product to be free from defects in material and workmanship for FIVE (5) YEARS FROM DATE OF PURCHASE, provided there has been normal use and proper maintenance. This warranty applies to the original purchaser only. All remedies under this warranty are limited to the repair replacement of the product itself, or the repair or replacement of any component part thereof, found by the factory to be defective within the time period specified. The decision to repair or replace is wholly within the discretion of the manufacturer.

This warranty specifically excludes labor. If you have a warranty claim, first you must call our factory at the number below for instructions. You must retain proof of purchase and submit a copy with any items returned for warranty work. Upon completion of warranty work, if any, we will return the repaired or replaced item or items to you freight prepaid. Damage to our products caused by accidents, fire, vandalism, negligence, misinstallation, misuse, acts by nature or by defective parts not manufactured by us, is not covered under this warranty.

ANY IMPLIED WARRANTIES OF MERCHANTABILITY AND/OR FITNESS FOR A PARTICULAR PURPOSE CREATED HEREBY ARE LIMITED IN DURATION TO THE SAME DURATION AND SCOPE AS THE EXPRESS WRITTEN WARRANTY. OUR COMPANY SHALL NOT BE LIABLE FOR ANY INCIDENTAL OR CONSEQUENTIAL DAMAGE.

Some states do not allow limitations on how long an implied warranty lasts, or the exclusion or limitation of incidental or consequential damages, so the above limitations or exclusions may not apply to you. This warranty gives you specific legal rights, and you may also have other rights that vary from state to state.

FOR WARRANTY ISSUES WITH THIS PRODUCT PLEASE CALL REALTRUCK TECH SUPPORT 1-888-983-2204

WARNING

Be sure to read and precisely follow the provided instructions when installing this product. Failure to do so could place the vehicle occupants in a potentially dangerous situation. After installing or reinstalling, re-check to insure that the product is properly installed.