

INSTALLATION GUIDE



Power Step

MADE IN USA



APPLICATION

AMP Part #

Ford Super Duty - Crew Cab 2002 - 2003

77106-01A

Note: The application works only on the Crew Cab model Vehicles.

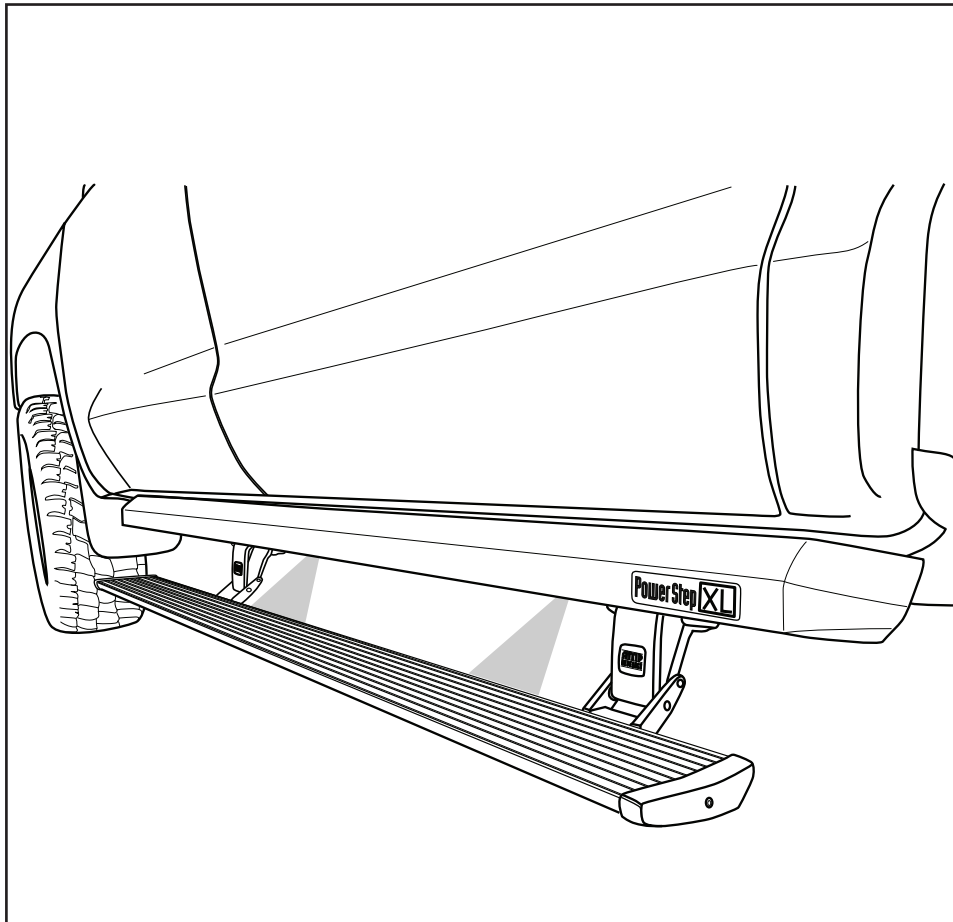

INSTALLATION TIME

3-5 Hours

Professional installation recommended

SKILL LEVEL



4= Experienced

TOOLS REQUIRED

- Safety goggles
- Measuring tape
- 10 mm socket
- 13 mm socket
- 1/2" socket
- Ratchet wrench and extension
- Wire crimpers
- Wire stripper / cutter
- 3/16" hex key wrench (allen wrench)
- 4mm hex key wrench (allen wrench)
- Electrical tape
- Weather proof caulking (silicone sealer)
- Silicone spray

WARRANTY

5-Year Limited Warranty

AMP RESEARCH TECH SUPPORT 1-888-983-2204 (Press 2) Monday - Friday, 7:00 AM - 5:00 PM PST

Invented, engineered and manufactured exclusively by AMP Research in the USA. May be covered by one OR MORE of the following patents: 6,641,158; 6,830,257; 6,834,875; 6,938,909; 7,055,839; 7,380,807; 7,413,204; 7,398,985; 7,584,975; 7,566,064; 7,487,986; 8,157,277; 8,408,571; 9,302,626; 9,561,751; 10,053,017; CA2463717 ©2012 AMP Research. All rights reserved. Printed in USA.

INSTALLATION GUIDE

Attaching motor to Linkage assembly.

EXPLODED VIEW

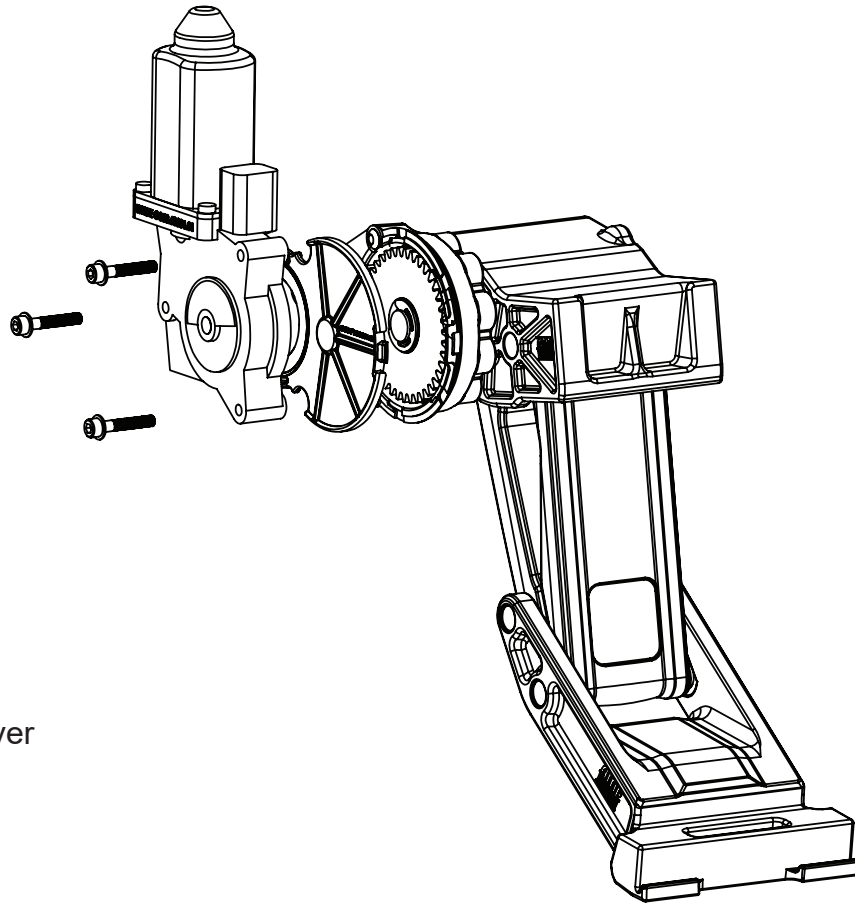

- Motor
- Socket cap screw
- Washer
- Drive Gear Housing Cover

CAUTION: HANDLE WITH CARE.

To ensure our customers receive all components with full integrity, we pack the motors separate from their linkage assemblies. This requires that the installer position and fasten the motor before continuing with the install. Please follow the instructions below and handle the assembly carefully.

CAUTION: Dropping the assembly or any excessive impact MAY cause damage to the motor.

Instructions:

1. Position the gear cover in place as shown if not already in place.
2. Seat motor into position on the three mounting bosses. This may require an adjustment of the gear by moving the swing arms.
3. After seating into place, fasten the motor with the three motor mount screws with 4mm Hex Head. Tighten screws to 36 in-lbs (4N-m). **Do not over torque.**

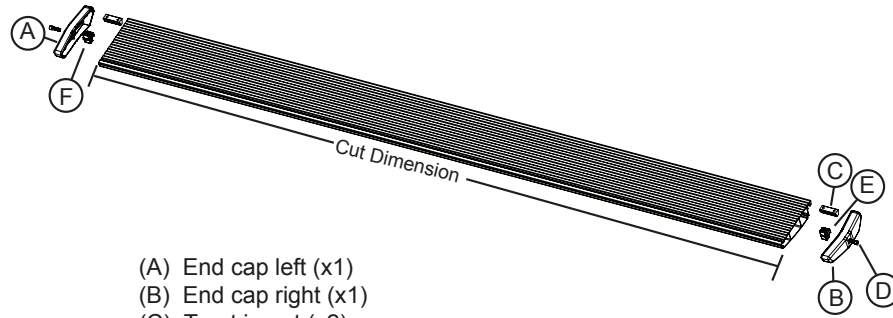

- (A) End cap left (x1)
- (B) End cap right (x1)
- (C) T-nut insert (x2)
- (D) Socket cap screw (x2)
- (E) End cap wedge right (x1)
- (F) End cap wedge left (x1)

1 x2

Running board assembly

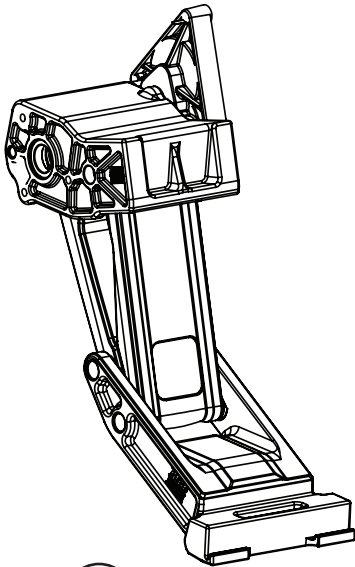

2 x2

Motor Linkage assembly

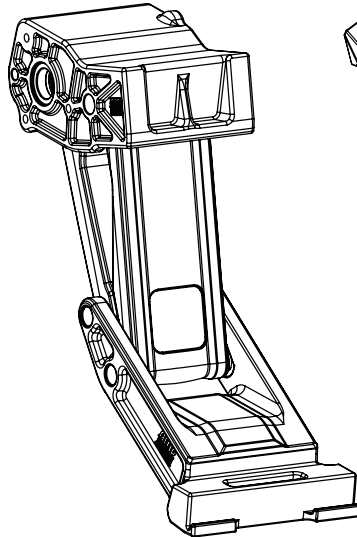

3 x2

Idler Linkage assembly

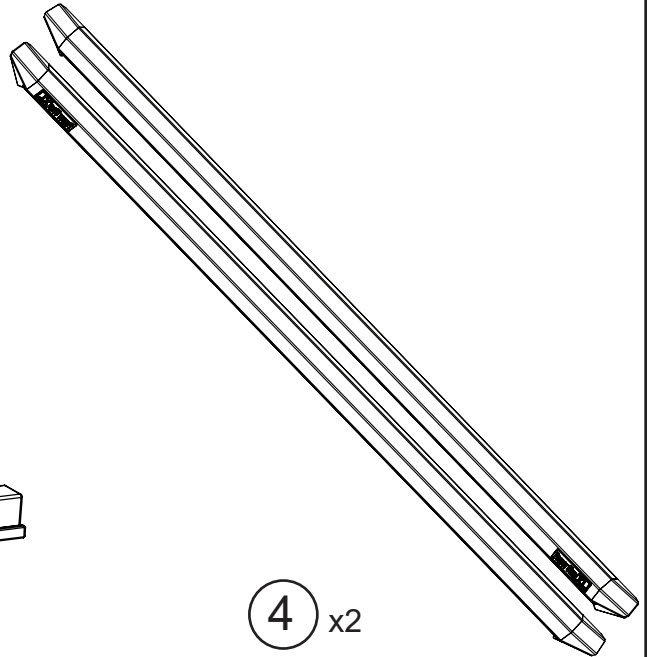

4 x2

Rail Assembly

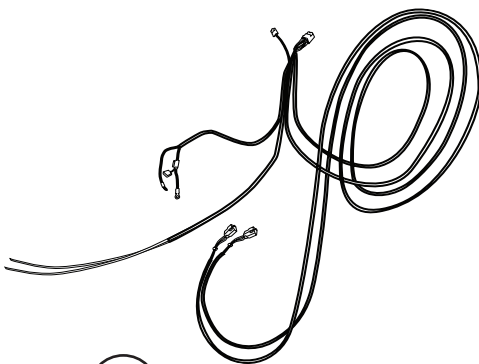

5

Wire harness

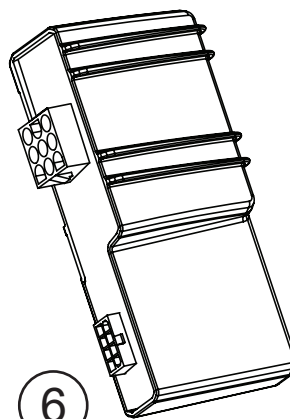

6

STB Controller

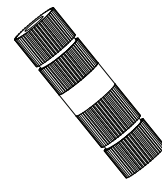

7 x4

Posi-Tap™

AMP RESEARCH POWERSTEP XL™ – FORD SuperDuty

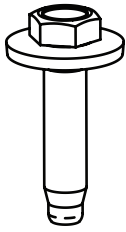

8 x18
M8 Hex Bolt w/
Conical washer

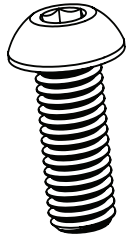

9 x10
M10 Button Head bolt

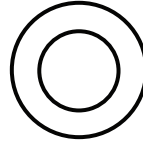

10 x10
M10 washer

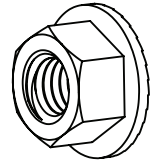

11 x10
Flange Nut

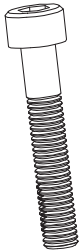

12 x6
M5 Hex Bolt



13 x6
M5 Washer

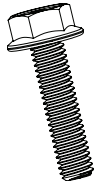

14 x4
M6 Flange Bolt

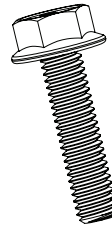

15 x6
5/16 Flange Bolt



16 x8
Socket Cap Screw

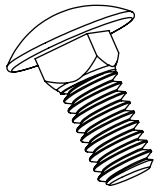

17 x14
5/16-18 Carriage Bolt

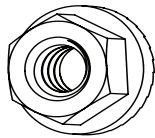

18 x20
5/16-18 Flange nut

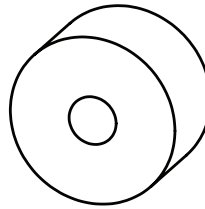

19 x4
Upper Mount Spacer

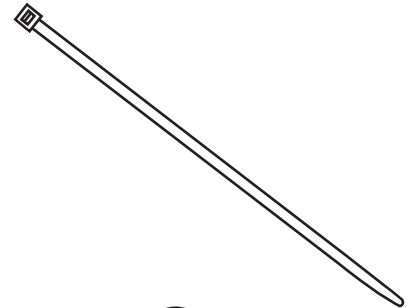

20 x2
Cable tie (11")



21 x10
M8 U-nut

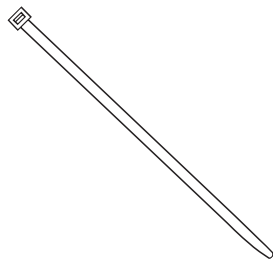

22 x20
Cable tie (7")

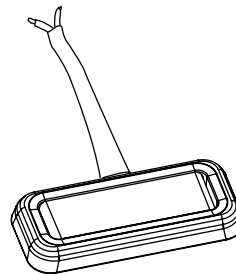

23 x4
LED Lamp

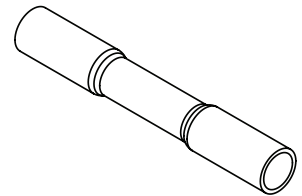

24 x10
Butt Connector

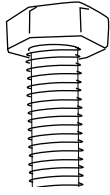

25
Socket cap screw

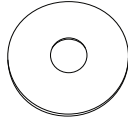

26
Large OD Washer



27
Nylock nut

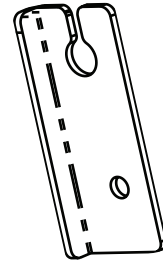

28
Brake cable bracket

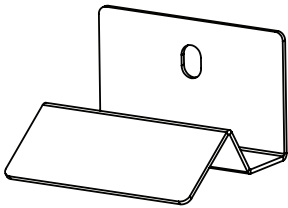

29 x4
LED Light Bracket

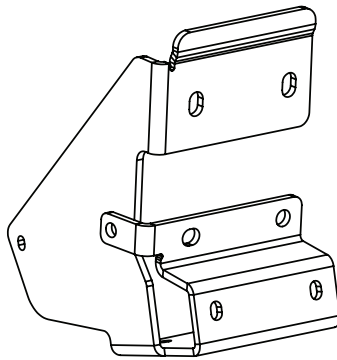

30 x4
Linkage Mounting Bracket

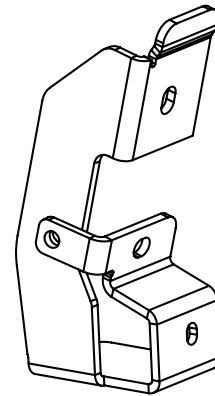

31 x2
Rail Mounting Bracket

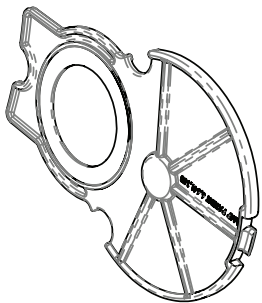

32 x2
Gear Cover

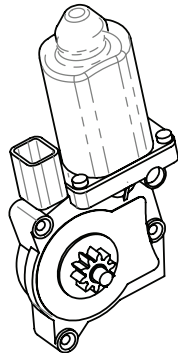

33 x2
Motor

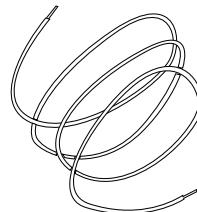

34 x2
Connecting wire (red)

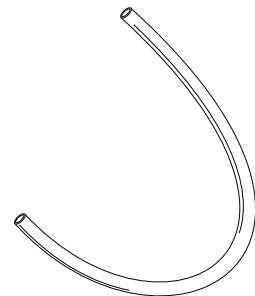

35
Tubing (installation tool)

AMP RESEARCH POWERSTEP XL™ – FORD SuperDuty

Insert 7 Carriage bolts (17) into slot on rail (4). Insert from either end of rail. Add 2 Light Brackets (29) on the 3rd and 5th bolt. Insert Flange nut (18) onto bracket tab to attach light brackets into position shown. Leave loose to allow for adjustment.

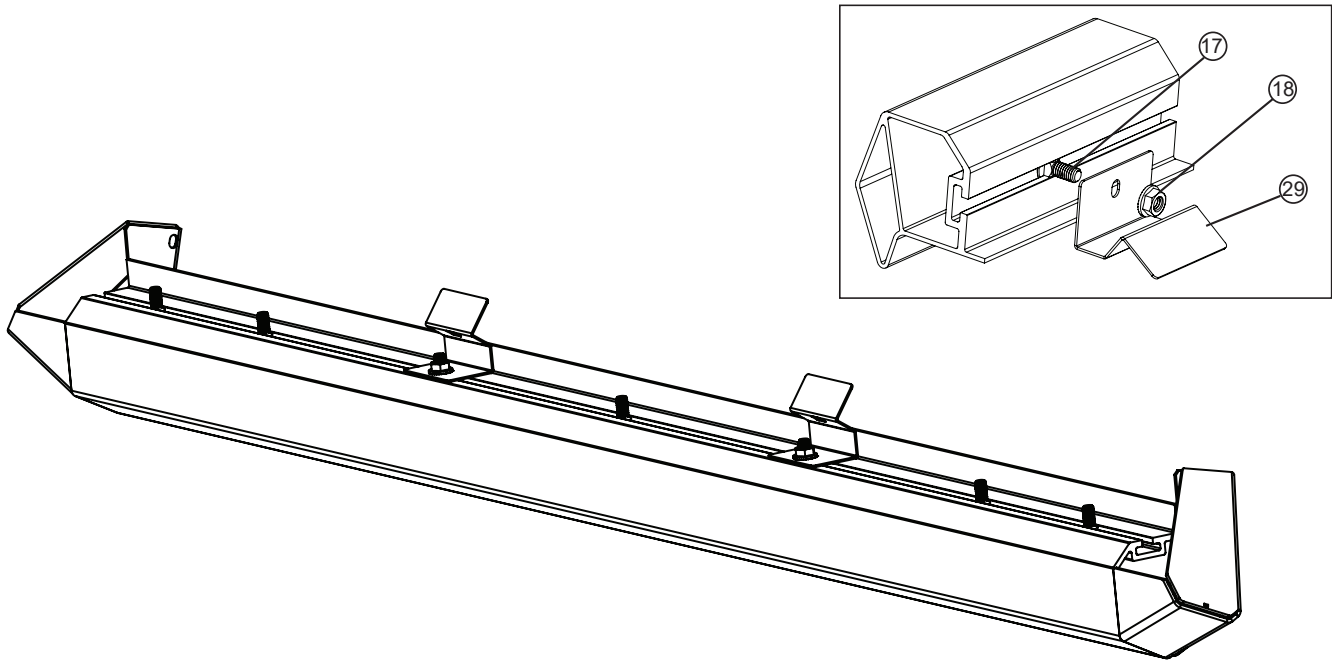

1

Using Flange Nuts (18), assemble Brackets 2x (30) & 1x (31) onto the rail (4), using the carriage bolts (17) left from previous step. Next, install Flange Bolt (15) and Flange Nut (18) onto bracket tab. Driver side shown. Dimensions shown are for reference.

Do not tighten this will allow for rail adjustment when mounted onto vehicle.

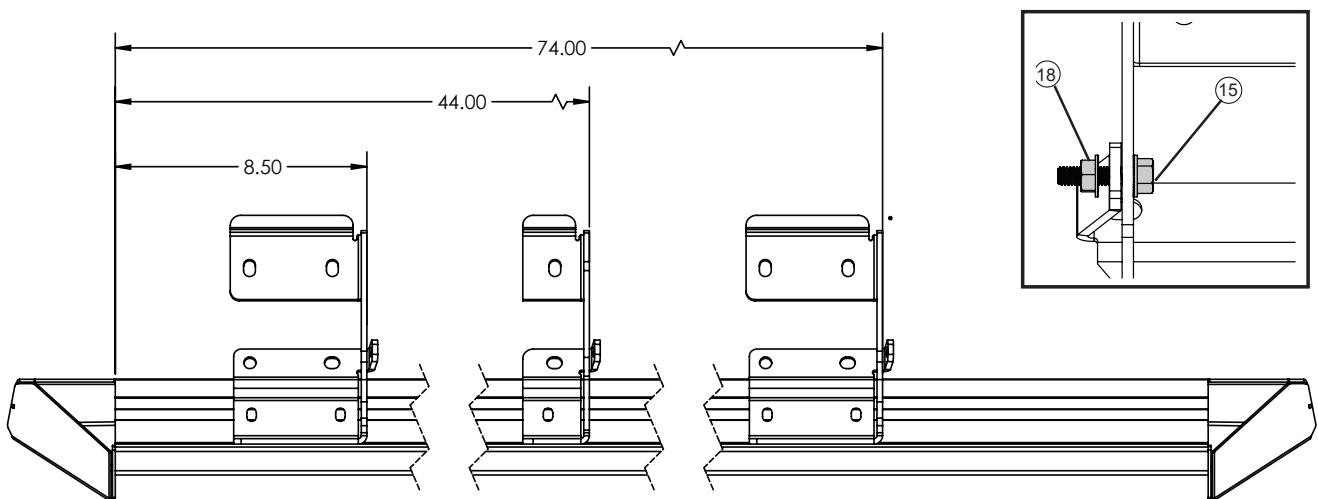

Note: Badge on rail sits towards the rear of the vehicle!

2

AMP RESEARCH POWERSTEP XL™ – FORD SuperDuty

Set rail up into position. Starting with the rear bracket work towards the two front brackets. Insert U-nuts (21) into position. Use provided button head bolts (9) with washers (10) and Flange Nut (11) on lower set of mount holes and captive washer bolt (8) on upper set of holes of brackets. Snug to body.

DRIVER SIDE

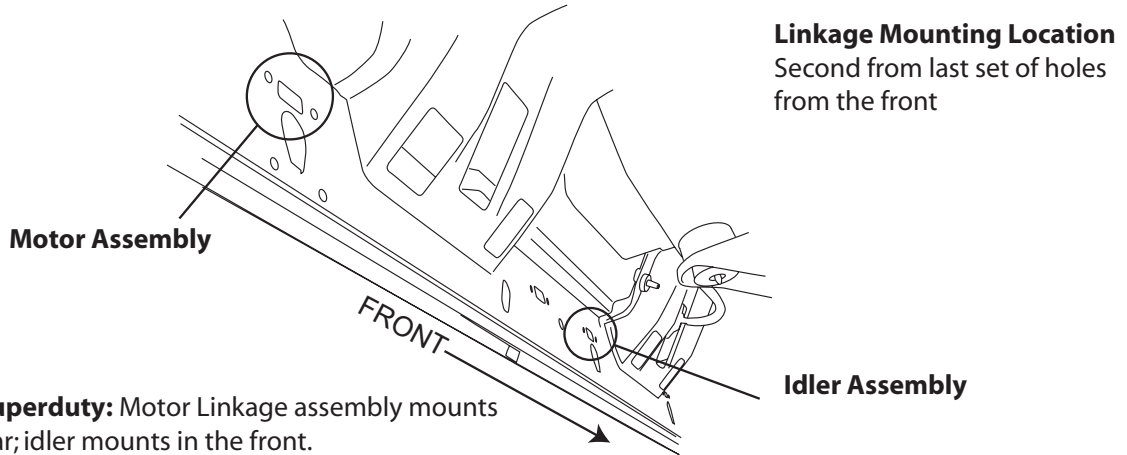

Note: Superduty: Motor Linkage assembly mounts in the rear; idler mounts in the front.

Excursion: Motor Linkage assembly mounts in the Front; idler mounts in the rear.

3

Thread supplied bolts 2x (8) into Rear Drive Linkage. Repeat step for Front Idler Linkage. Do not tighten.

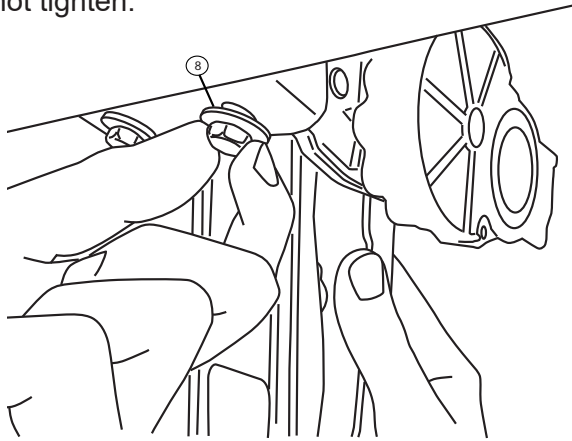

4

Install provided spacer (19) and M6 bolt (14) into upper mount as shown on both the Drive and Idler linkages. Do not tighten.

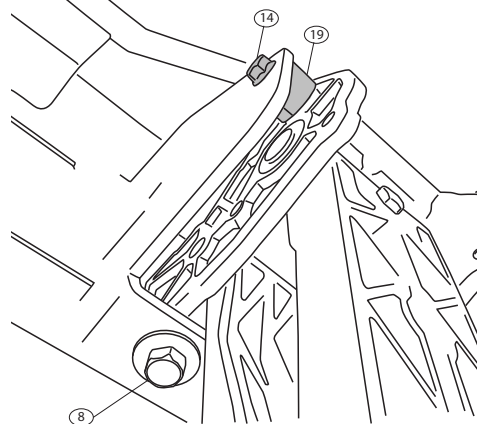

5

Slide mounting T-nut into position, Center board in rail pocket. Tighten fasteners to 10 ft-lbs.

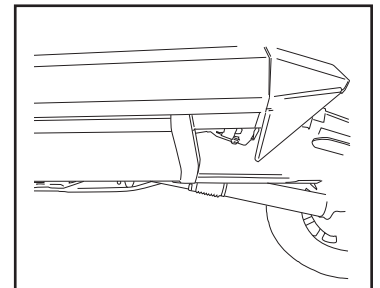
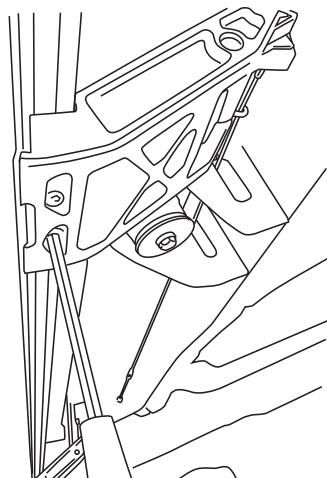

6

AMP RESEARCH POWERSTEP XL™ – FORD SuperDuty

Using a 13mm socket Torque linkage bolts 4x (8) from step 4 to 16 ft-lbs. Next use a 10mm socket, torque linkage spacer bolt 2x (14) from step 5 to 8 ft-lbs. Once linkages are tight cycle board to verify steps deploy under own weight.

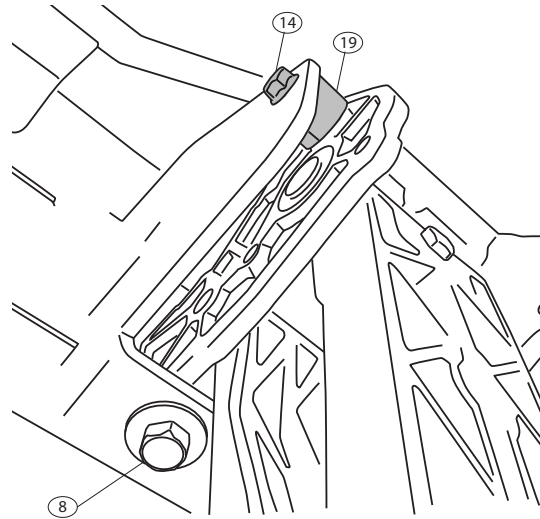

7

Start from rear of vehicle tighten brackets to the body of the vehicle. First Torque Button Head Bolts (10) to 16ft-lbs and then tighten Captive washer bolts (8) to 16 ft-lbs.

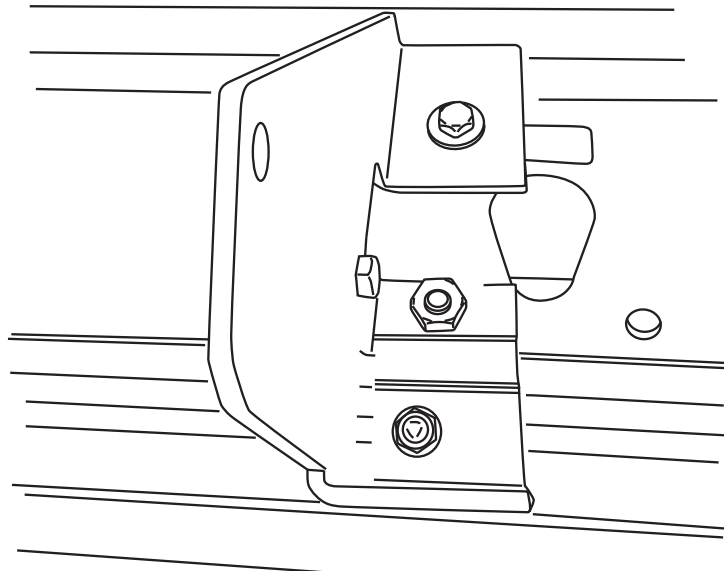

8

Attach motor to harness. Using a 4mm hex Torque to 36 in-Lbs.

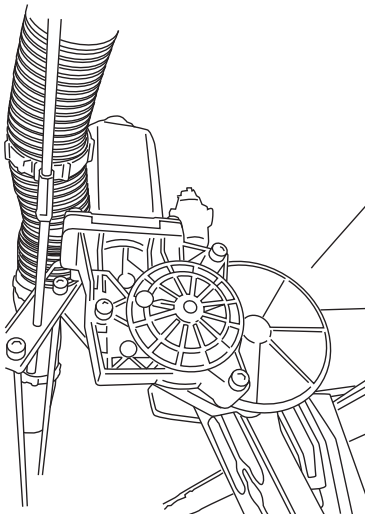

9

Torque bolts on mounting brackets as shown to 16ft-lbs.

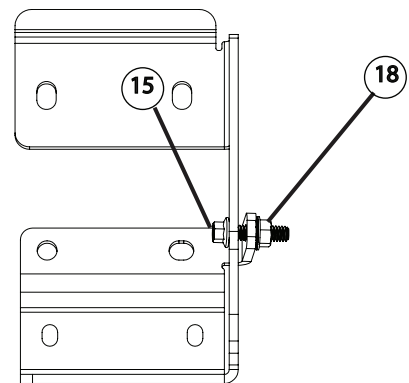

10

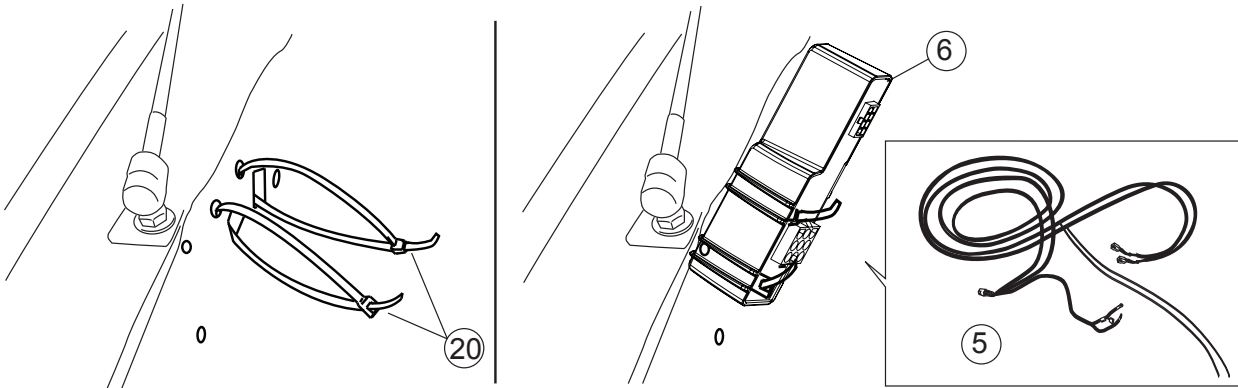

Loop two large tie wraps through fastener cutouts in sheet metal as shown. Position controller as shown above and cinch down tie wraps to secure controller in place. Connect harness to controller. Make sure that locking tabs on controller/harness connector are fully engaged.

11

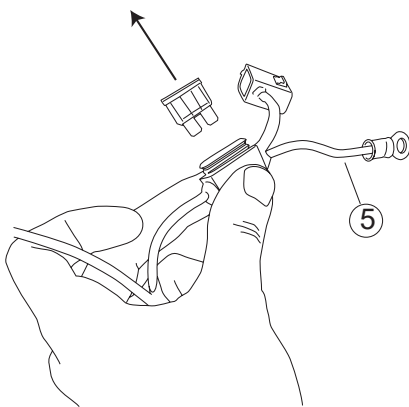

12

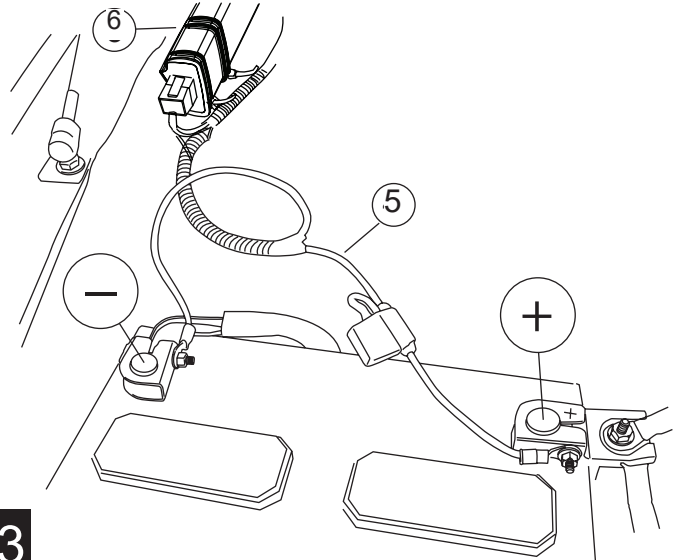

13

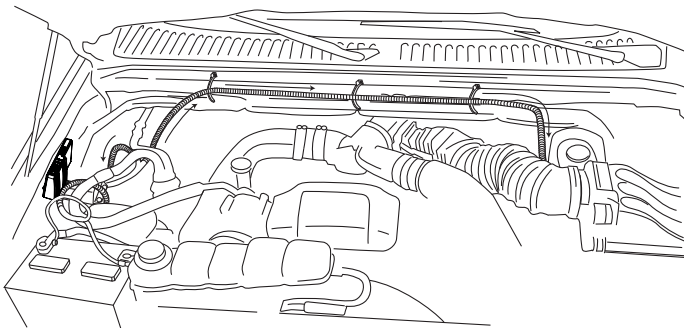

14

Puncture grommet and thread trigger wire

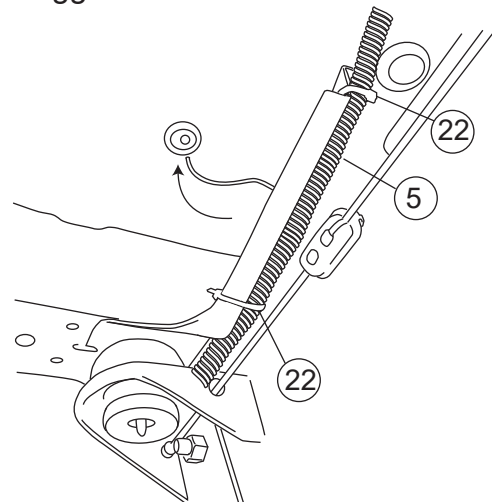

15

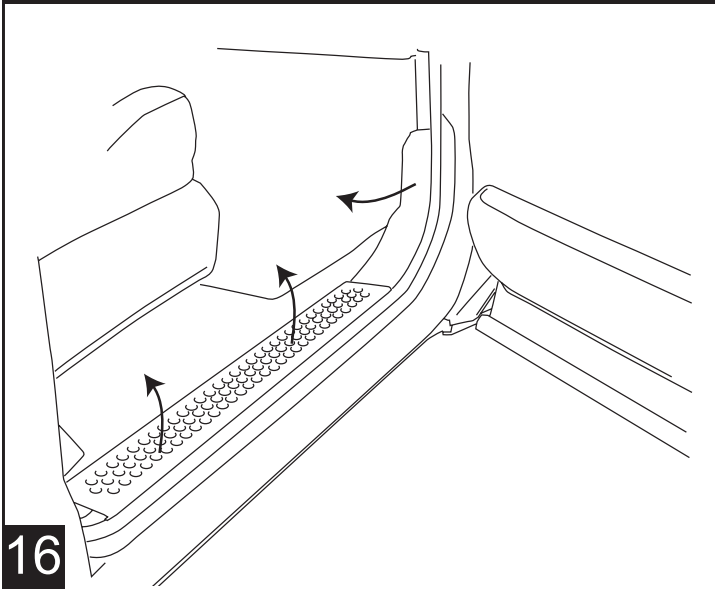

16

Remove kick plate

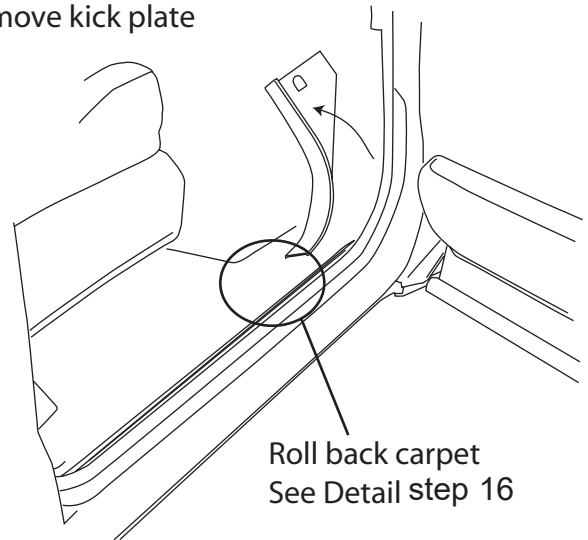

17

The Green and Green/Violet wires need to be routed over to the driver side of the vehicle. Attach extra wire length to both wires on the harness (Green and Green/Violet), and run under carpet from passenger side to driver side.

Open driver side door and remove sill plate and kick panel. Lift carpet and pull trigger wires to driver side.



18

Remove driver side front door panel. This will require removing multiple concealed bolts and paneling.



19

Door panel removal will require removal of door light lens and window corner trim.

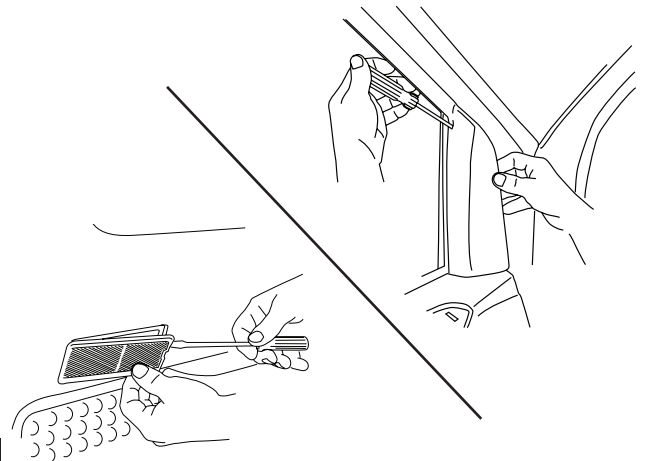

20

Remove speaker and pull back door lining.

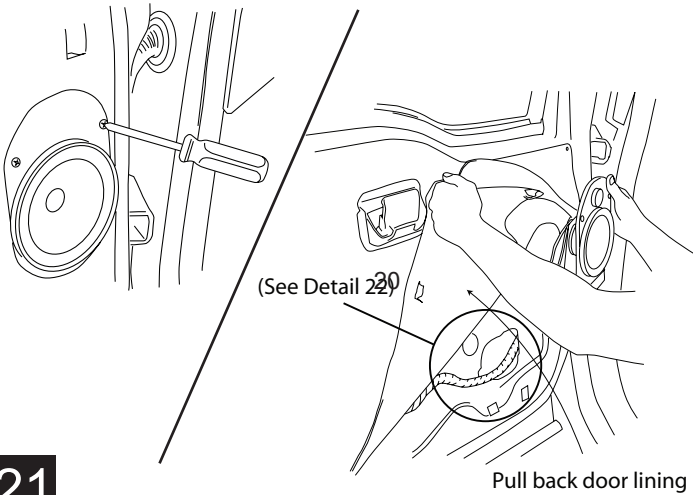

Insert plastic tubing (for wire routing) and run one trigger wire through to door compartment. Then remove the plastic tubing, pulling from door side.

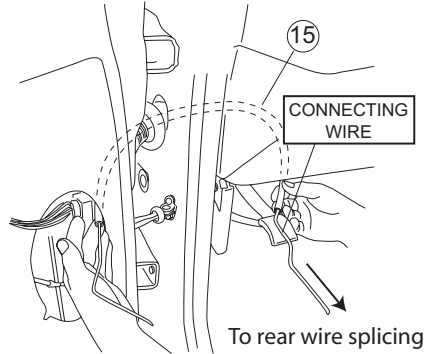

21

22

Posi-Tap™ instructions

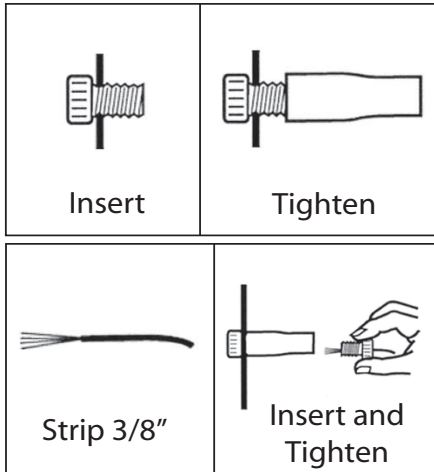

Driver Front Door Wiring: Using Posi-Tap™ (7) connector, connect the supplied additional wire (Red) to front door ajar wire (Yellow w/Black stripe)

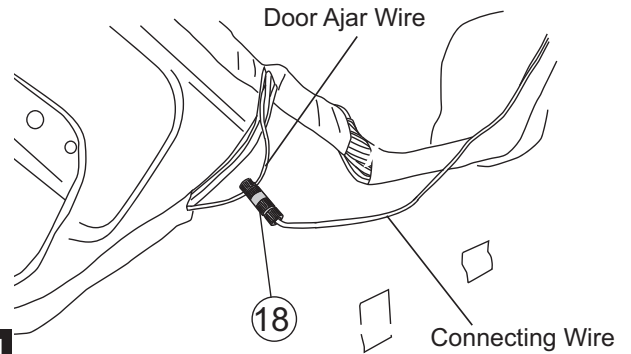

23

24

Driver Front Door Wiring: Using Posi-Tap™ (7) connector, connect the supplied additional wire (Red) to front door ajar wire (Yellow w/Black stripe)

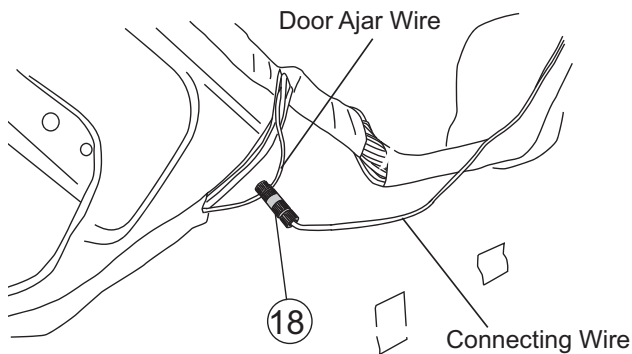

CAUTION: You will find two wires with these colors; the correct wire will ground when the rear door is closed and OL with the rear door open.

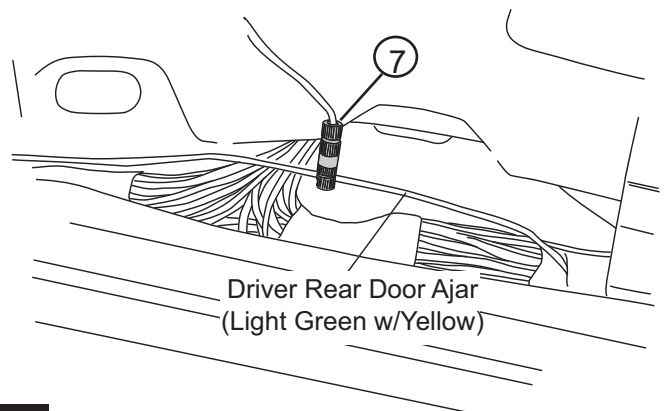

25

26

Passenger Front Door Wiring: Using Posi-Tap™ (7) connector, connect white trigger wire to front door ajar wire (Grey w/Red stripe). Run Yellow trigger wire toward rear.

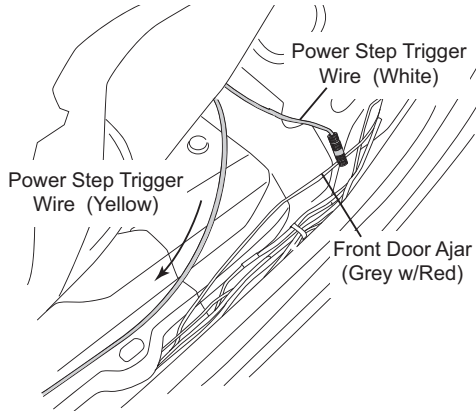

27

Passenger Rear Door Wiring: Using Posi-Tap connector, connect Yellow trigger wire to rear door ajar wire (Pink w/Light Blue stripe). This wire is found rear of junction where wires route under front passenger seat.

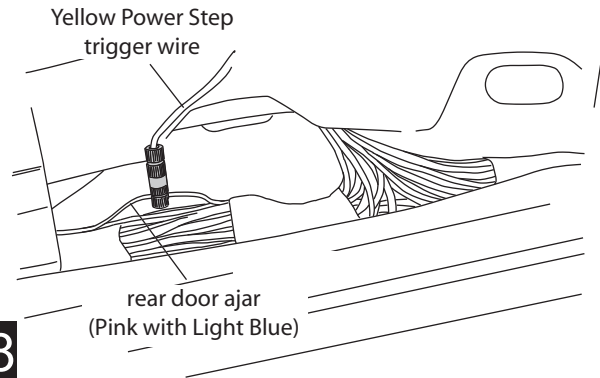

28

For vehicles without factory remote keyless entry, contact AMP Research for additional instructions.

**AMP Research Tech Support:
1-888-983-2204 (Press 2)**

29

Connect harness to motor. Secure harness with tie wraps.

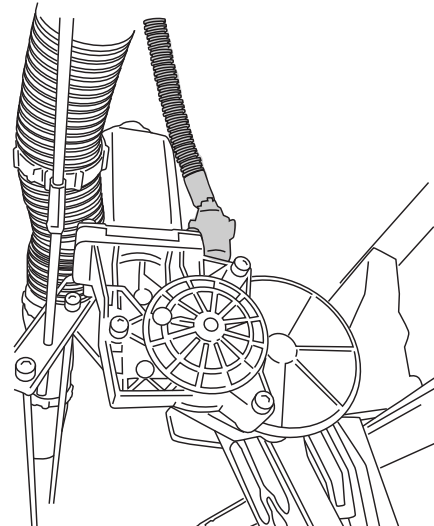

30

Affix LED lamp (23) to LED Bracket (29) as shown. Slide bracket into desired position and tighten using 5/32" Allen key.

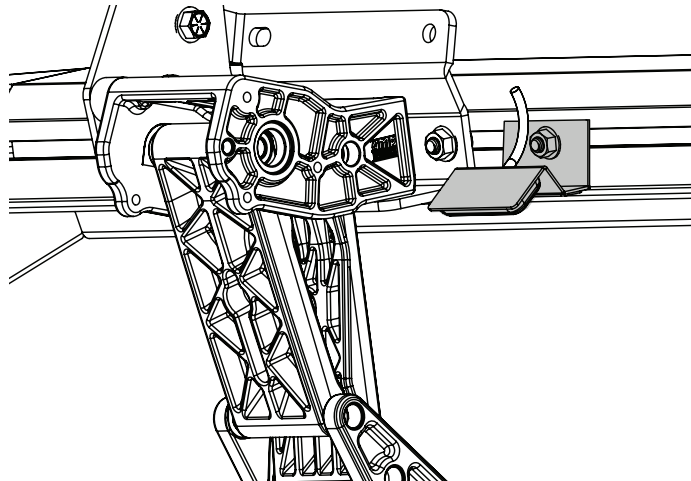
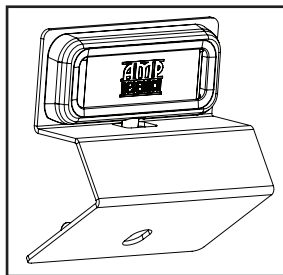

31

Using supplied butt connectors (24), connect the lamp wires. Red to Red, Black to Black. Once Crimped use heat gun to shrink tube. Close and wrap conduit with electrical tape. Secure all loose wires with cable ties. Pull lamp wires upward to avoid any wire snagging.

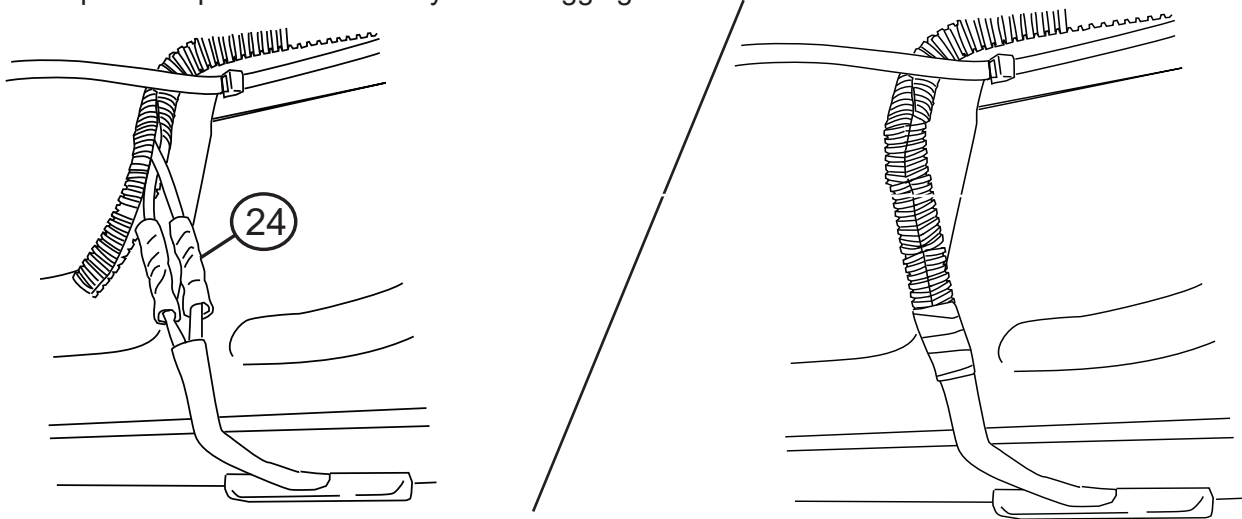

32

Check that all doors activate the Power Step and the LED Lights work when doors open and close. Reinstall any remaining trim panels.

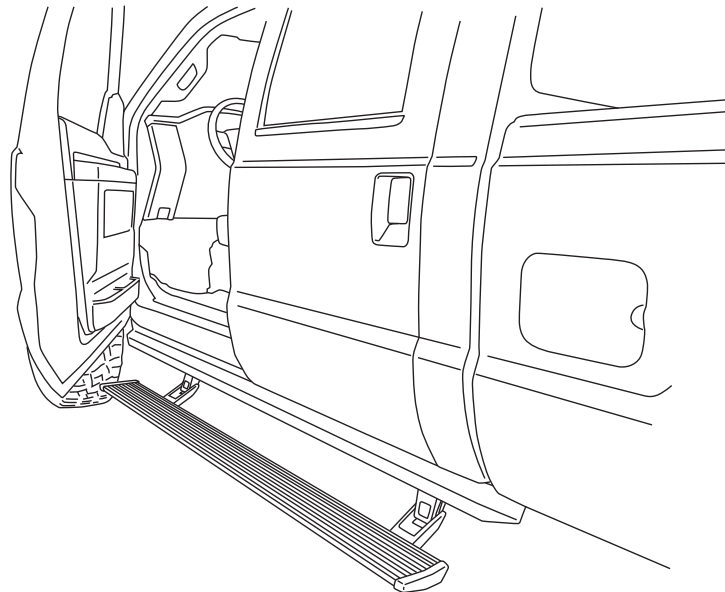

FINAL SYSTEM CHECK

Check that all doors activate the PowerStep and the LED lights work when doors open and close.

NORMAL OPERATION: When the doors open, PowerStep automatically deploys from under the vehicle. When the doors are closed, PowerStep will automatically return to the stowed/retracted position. **Note that there is a 2-second delay before the PowerStep returns to the stowed/retracted position.**

CORRECT OPERATION OF LIGHTS: All four lamps will illuminate upon opening any door of vehicle. Lamps will stay on until restowing of both Power Steps or until 5 minutes has expired with the doors open. When the lights timeout after 5 minutes, they can be reilluminated by closing and opening any door of vehicle.

33

AMP **RESEARCH** **Power Step**™

AMERICAN DESIGNED, ENGINEERED AND MANUFACTURED.

Thank you for your recent AMP Research Purchase.

REGISTER YOUR PRODUCT TODAY FOR FASTER SERVICE & PRODUCT UPDATES

Please visit:

www.amp-research.com/productregistration
or scan the QR Code



Product Registration Benefits:

- Ensure we have your purchase receipt and product info in our system which is required for warranty
- Faster and easier access to customer service and tech support in the unlikely event you need warranty or product support
- Registration helps us keep you up to date on product information and offers

To view other Amp Research products that may be offered for your vehicle.

Please visit: www.amp-research.com

Rev 01.05.21

POWER-DEPLOYABLE RUNNING BOARDS OPERATION: AMP Research PowerStep running boards automatically move when the doors are opened to assist entering and exiting the vehicle.

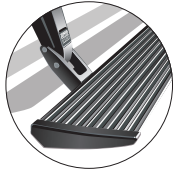

Automatic power deploy:

The running boards will extend down and out when the doors are opened.

Automatic power stow:

The running boards will return to the stowed position when the doors are closed. There will be a 2-second delay before the running boards move to the stowed position.

Automatic stop:

If an object is in the way of the moving running board, the running board will automatically stop. To reset, clear any obstruction, then simply open and close the door to resume normal operation.



Manually set in the deployed (OUT) position for access to the roof:

The running boards can be manually set in the deployed position by firmly holding the step down with your foot while at the same time closing the door. To resume normal operation, open and close the door.

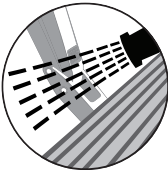

Maintenance: In adverse conditions, debris such as mud, dirt, and salt may become trapped in the running board mechanism, possibly leading to unwanted noise. If this occurs, manually set the running boards to the deployed position and flush the front and rear hinge arms with a high-pressure car wash wand.

Avoid spraying the motors directly. After washing, apply silicone spray lubricant to the hinge pivot pins. Do not apply silicone, wax or protectants like Armor All® to the running board stepping surface.

Caution! Keep hands away when the running board is in motion.

5-YEAR LIMITED WARRANTY

AMP RESEARCH warrants this product to be free from defects in material and workmanship for FIVE (5) YEARS FROM DATE OF PURCHASE, provided there has been normal use and proper maintenance. This warranty applies to the original purchaser only. All remedies under this warranty are limited to the repair replacement of the product itself, or the repair or replacement of any component part thereof, found by the factory to be defective within the time period specified. The decision to repair or replace is wholly within the discretion of the manufacturer.

This warranty specifically excludes labor. If you have a warranty claim, first you must call our factory at the number below for instructions. You must retain proof of purchase and submit a copy with any items returned for warranty work. Upon completion of warranty work, if any, we will return the repaired or replaced item or items to you freight prepaid. Damage to our products caused by accidents, fire, vandalism, negligence, misinstallation, misuse, Acts of God, or by defective parts not manufactured by us, is not covered under this warranty.

ANY IMPLIED WARRANTIES OF MERCHANTABILITY AND/OR FITNESS FOR A PARTICULAR PURPOSE CREATED HEREBY ARE LIMITED IN DURATION TO THE SAME DURATION AND SCOPE AS THE EXPRESS WRITTEN WARRANTY. OUR COMPANY SHALL NOT BE LIABLE FOR ANY INCIDENTAL OR CONSEQUENTIAL DAMAGE.

Some states do not allow limitations on how long an implied warranty lasts, or the exclusion or limitation of incidental or consequential damages, so the above limitations or exclusions may not apply to you. This warranty gives you specific legal rights, and you may also have other rights that vary from state to state.

FOR WARRANTY ISSUES WITH THIS PRODUCT PLEASE CALL AMP RESEARCH TECH SUPPORT 1-888-983-2204

WARNING

Be sure to read and precisely follow the provided instructions when installing this product. Failure to do so could place the vehicle occupants in a potentially dangerous situation. After installing or reinstalling, re-check to insure that the product is properly installed.



The material that your product is made from can be recycled. Please also consider recycling the packaging that your product came in.

