

AMP RESEARCH BedStep2™

APPLICATION
Dodge Ram DS
1500
2500 / 3500
3500 - Excludes 2013 dually w 8' Bed

AMP PART 75406-01A

2009-2023
2010-2013

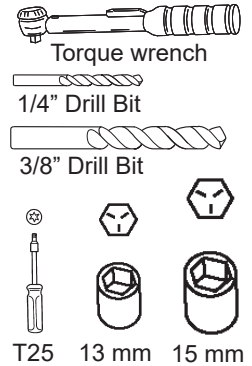
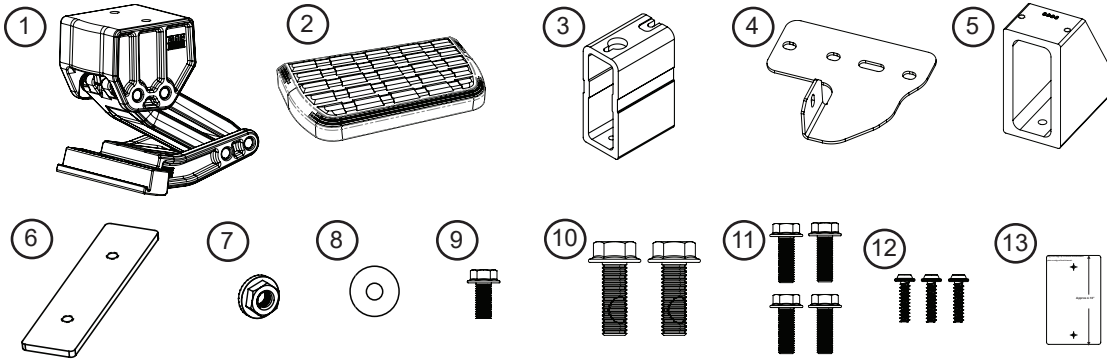

For 6.5' & 8' bed lengths components must be configured for Passenger or Drivers-Side as shown.

NOTE: For Dually w 8' Bed applications see kit 75611-01A for proper bracket orientation.

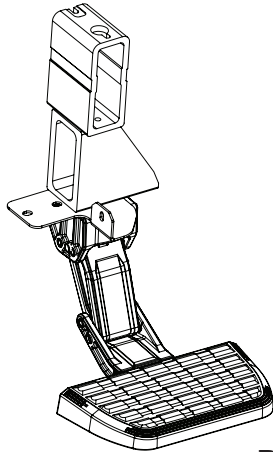

Driver-Side Orientation

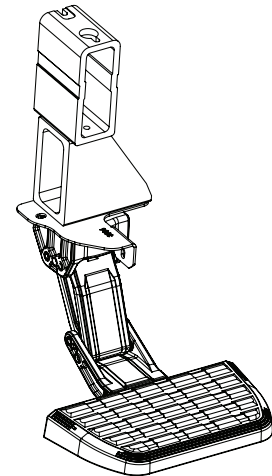

Passenger-Side Orientation

For 5.5' bed length components must be configured for Passenger or Drivers-Side as shown.

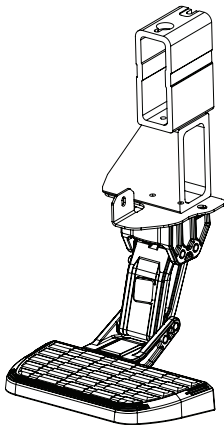

1

Driver-Side Orientation

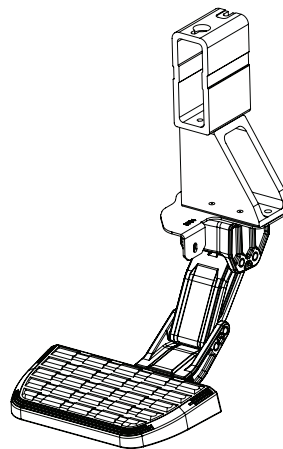

Passenger-Side Orientation

AMP RESEARCH TECH SUPPORT 1-888-983-2204 (Press 2) Monday - Friday, 7:00 AM - 5:00 PM PST

BedStep2™ is invented, designed, engineered and manufactured exclusively by AMP Research and may be covered by one of the following patents: 6,641,158; 6,830,257; 6,938,909; 7,055,839; 7,380,807; 7,398,985; 7,584,975. Made in USA © 2023 AMP Research 3172 Nasa St. Brea, CA 92821
Three-year limited warranty. Professional installation is recommended.

Use supplied drill template and mark holes in front bed channel mount. Pre drill holes using 1/4" drill bit. Next drill hole to 3/8".

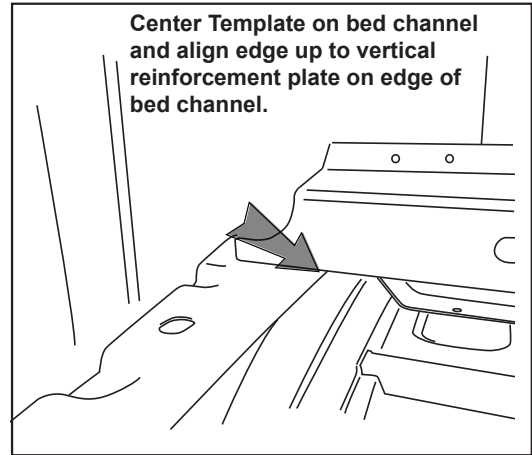
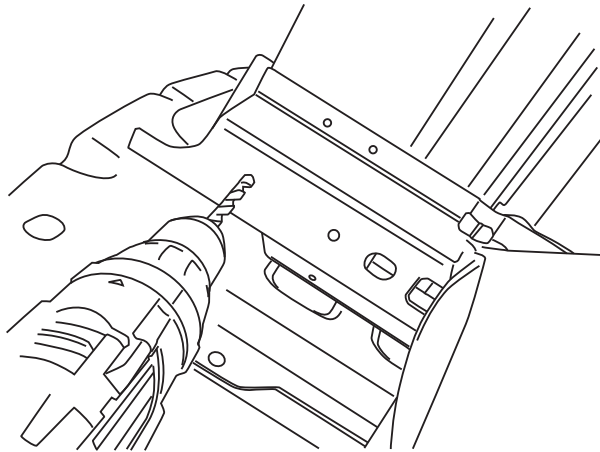

Center Template on bed channel and align edge up to vertical reinforcement plate on edge of bed channel.

2

Using a 13mm Socket assemble the frame mount. Torque bolts to 16 ft-lbs.

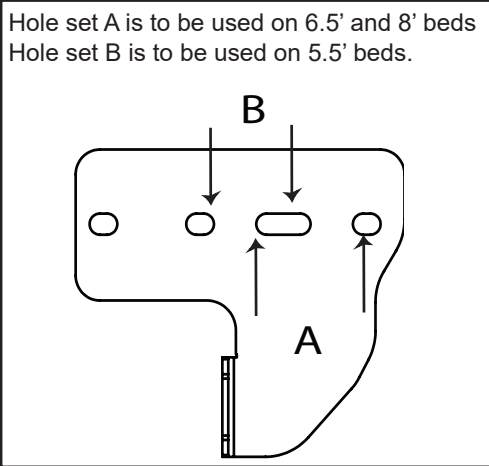

Hole set A is to be used on 6.5' and 8' beds
Hole set B is to be used on 5.5' beds.

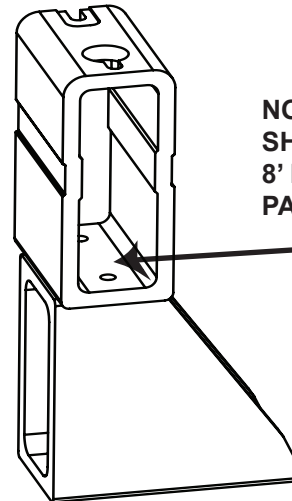

NOTE: DRIVER SIDE SHOWN WITH 6.5' & 8' BED. MIRROR FOR PASSENGER SIDE.

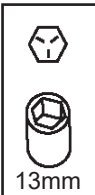

13mm

3

Slide threaded plate into bed channel and line up threaded locations to pre drilled holes.

Thread screws into threaded plate. Allow room for frame mount to slide up into position.

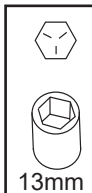
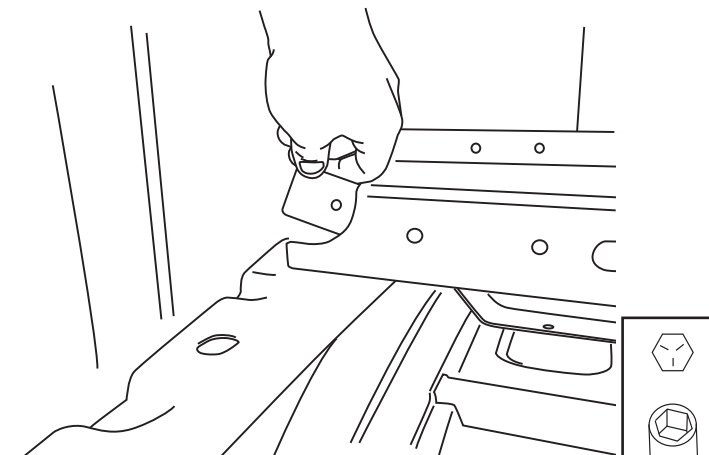

13mm

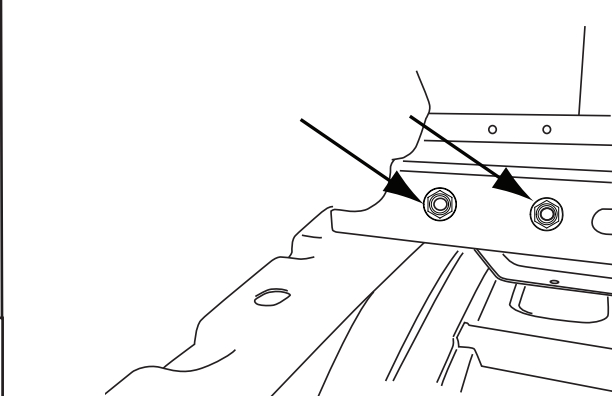

4

5

Using a 13mm Socket with extension, slide linkage assembly into slots in frame mount. Torque to 16ft-lbs.

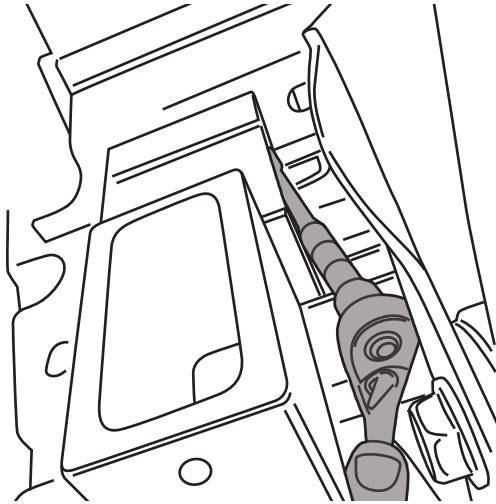

6

Set bolts into lower lateral mount. Set bracket into place and use provided hardware to bolt bracket to inner bed brace.

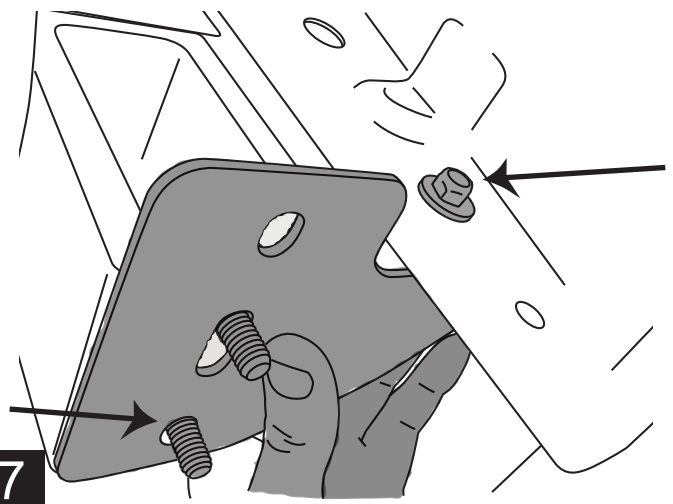

7

Set linkage into position, tighten bolts using 15mm Socket. Torque to 20 ft-lbs.

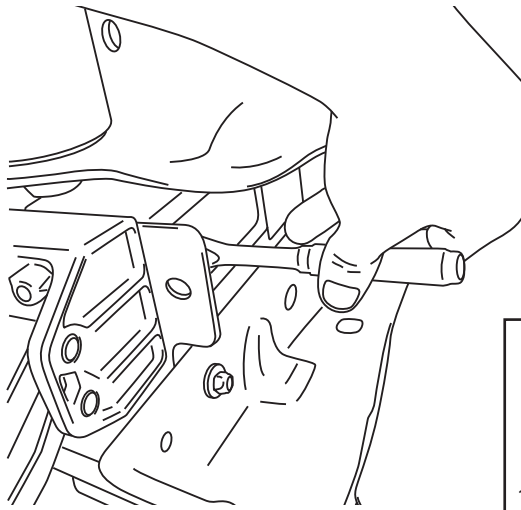

8

Tighten bracket bolt with 13mm socket and wrench. Torque to 16 ft-lbs.

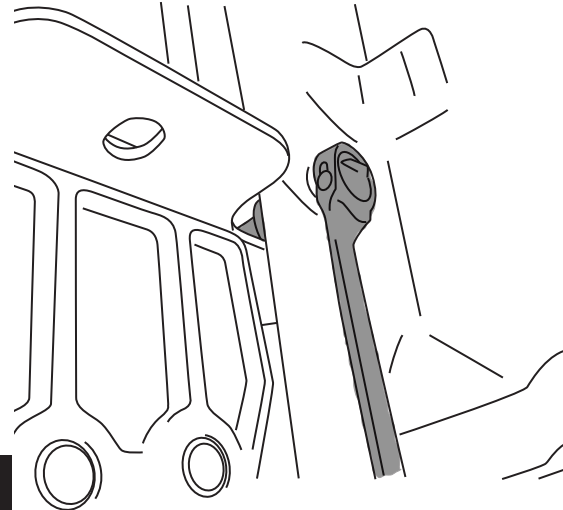

9

Locate the step pad in the following positions per application. Crew Cab 1500 offset step pad rearward. All other applications mount step pad in center position. Torque to 5 Ft-Lbs.

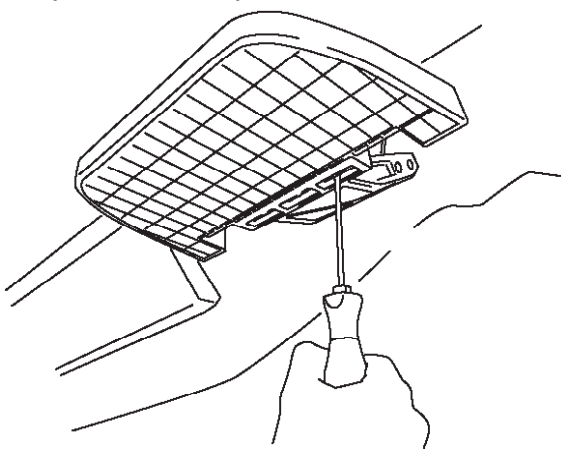

10

Verify step pad alignment to body line of vehicle.

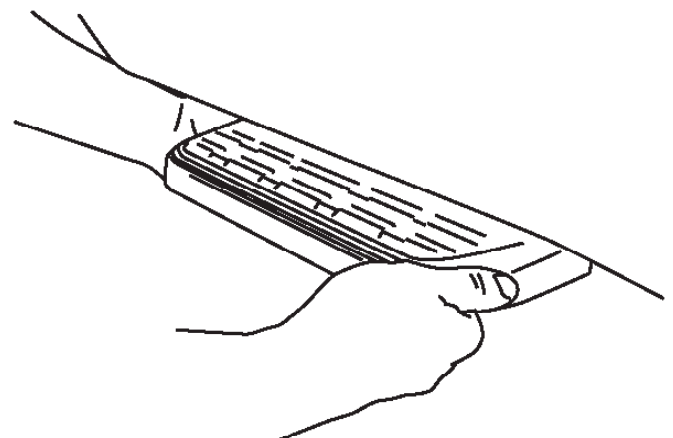

11

To deploy the step, press down using your foot on the outside edge of the step pad.

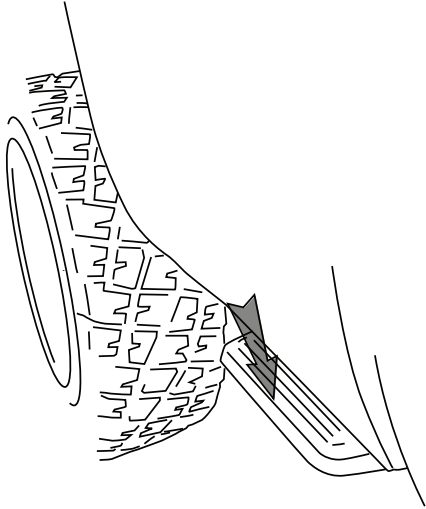

12

To retract, gently kick up on the underside of the step pad.

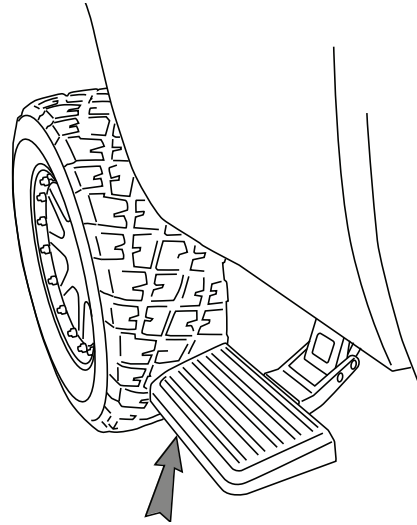

13



Congratulations on your purchase of the genuine AMP Research BedStep2™. Here's what you should know...

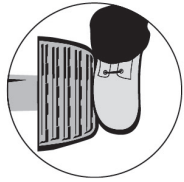

BEDSTEP2™ OPERATION

The AMP Research BedStep2™ is foot operated and deploys and retracts with a nudge of your foot. To deploy, press down using your foot, on the outside edge of the step pad. Maximum load capacity of the deployed step pad is 300 lbs. Always use appropriate hand holds when stepping up to or down from your truck's cargo bed.



To retract, gently kick up on the underside of the step pad.

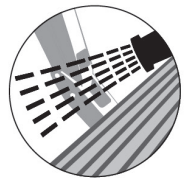

MAINTENANCE TIPS - The stepping surface and linkage should be periodically washed with mild soap and water using a soft brush or sponge to dislodge any mud, dirt or accumulated road grime. **In severe driving conditions, pressure washing the linkage is strongly recommended.** Do not apply silicone spray, waxes or protectants like Armor All® to the stepping surfaces.

CAUTION! BEDSTEP2™ SHOULD ALWAYS BE STOWED IN THE RETRACTED POSITION WHEN DRIVING.

AMP RESEARCH LIMITED WARRANTY

AMP RESEARCH warrants this product to be free from defects in material and workmanship for THREE (3) YEARS FROM DATE OF PURCHASE, provided there has been normal use and proper maintenance. This warranty applies to the original purchaser only. All remedies under this warranty are limited to the repair replacement of the product itself, or the repair or replacement of any component part thereof, found by the factory to be defective within the time period specified. The decision to repair or replace is wholly within the discretion of the manufacturer.

This warranty specifically excludes labor. If you have a warranty claim, first you must call our factory at the number below for instructions. You must retain proof of purchase and submit a copy with any items returned for warranty work. Upon completion of warranty work, if any, we will return the repaired or replaced item or items to you freight prepaid. Damage to our products caused by accidents, fire, vandalism, negligence, misinstallation, misuse, Acts of God, or by defective parts not manufactured by us, is not covered under this warranty.

ANY IMPLIED WARRANTIES OF MERCHANTABILITY AND/OR FITNESS FOR A PARTICULAR PURPOSE CREATED HEREBY ARE LIMITED IN DURATION TO THE SAME DURATION AND SCOPE AS THE EXPRESS WRITTEN WARRANTY. OUR COMPANY SHALL NOT BE LIABLE FOR ANY INCIDENTAL OR CONSEQUENTIAL DAMAGE.

Some states do not allow limitations on how long an implied warranty lasts, or the exclusion or limitation of incidental or consequential damages, so the above limitations or exclusions may not apply to you. This warranty gives you specific legal rights, and you may also have other rights that vary from state to state.

FOR WARRANTY ISSUES WITH THIS PRODUCT PLEASE CALL AMP RESEARCH CUSTOMER SERVICE 1-888-983-2204

WARNING

Be sure to read and precisely follow the provided instructions when installing this product. Failure to do so could place the vehicle occupants in a potentially dangerous situation. After installing or reinstalling, re-check to insure that the product is properly installed.



The material that your product is made from can be recycled. Please also consider recycling the packaging that your product came in.

