

INSTALLATION INSTRUCTIONS

PRO-SERIES FRONT BUMPER



APPLICATION: 2016-2020 Toyota Tacoma

PART NUMBER: 58-411045

CONTENT			
ITEM	QUANTITY	DESCRIPTION	TOOLS NEEDED
1	1	PRO SERIES FRONT BUMPER	13MM SOCKET
2	1	WINCH TRAY	14MM SOCKET
3	1	LED LIGHT COVER	RATCHET
4	1	DRIVER LED LIGHT BRACKET	TORQUE WRENCH
5	1	PASSENGER LED LIGHT BRACKET	10MM SOCKET
6	1	DRIVER SUPPORT BRACKET	CUTTING TOOL
7	1	PASSENGER SUPPORT BRACKET	RULER
8	1	DRIVER MAIN BRACKET	MARKER
9	1	PASSENGER MAIN BRACKET	PRY TOOL
10	3	RELOCATION BRACKET	GRINDER
11	2	RUBBER TRIM	CUT OFF WHEEL
12	4	M6 COUNTERSUNK HEX HEAD SCREW	
13	4	M6 BUTTON HEAD BOLT	
14	8	M6 FLAT WASHER	
15	8	M6 SERRATED FLANGE NUT	
16	3	M8 HEX HEAD BOLT	
17	3	M8 LOCK WASHER	
18	3	M8 FLAT WASHER	
19	3	M8 SERRATED FLANGE NUT	
20	6	M12 LONG HEX HEAD BOLT	
21	12	M12 SHORT HEX HEAD BOLT	
22	36	M12 FLAT WASHER	
23	18	M12 SERRATED FLANGE NUT	

ANTI-SEIZE LUBRICANT MUST BE USED ON ALL STAINLESS STEEL FASTENERS TO PREVENT THREAD DAMAGE AND GALLING

PROCEDURE

1. Remove contents from box, verify if all parts listed are present and free from damage.
Carefully read and understand all instructions before attempting installation.
Failure to identify damage before installation could lead to a rejection of any claim.

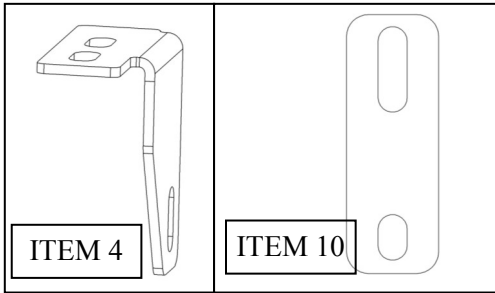
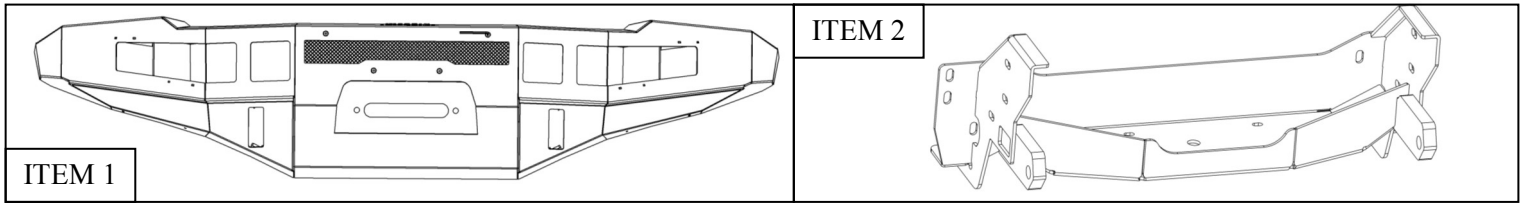

2. To remove front bumper, first remove the grill, fender flares and valance. To remove grill, remove two screws and push pins fastening it to the radiator area. See **Figure 1 and 2**. Once all fasteners have been removed, firmly pull radiator from top towards the front of the vehicle.

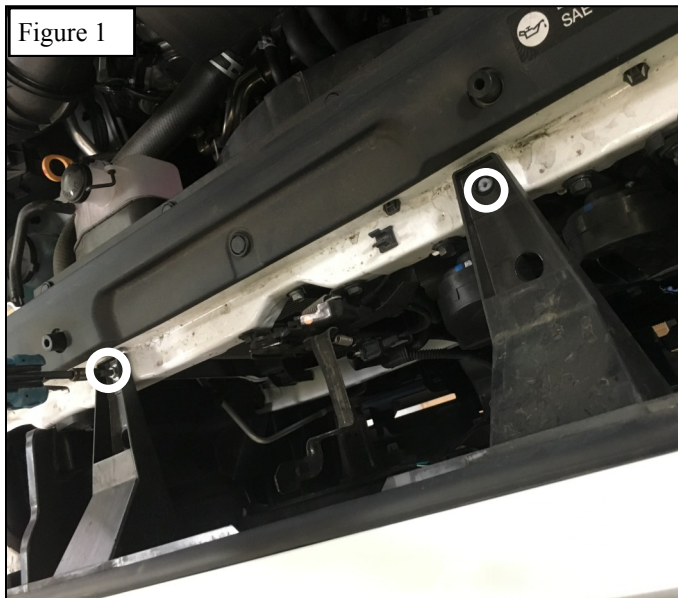

3. Next, remove fender flares by removing screws around the wheel well area; once all visible fasteners have been removed, firmly and carefully pull to unclip push pins. Save fender flares for later. They will be installed back and trimmed. See Figure 3

Figure 3



Figure 4

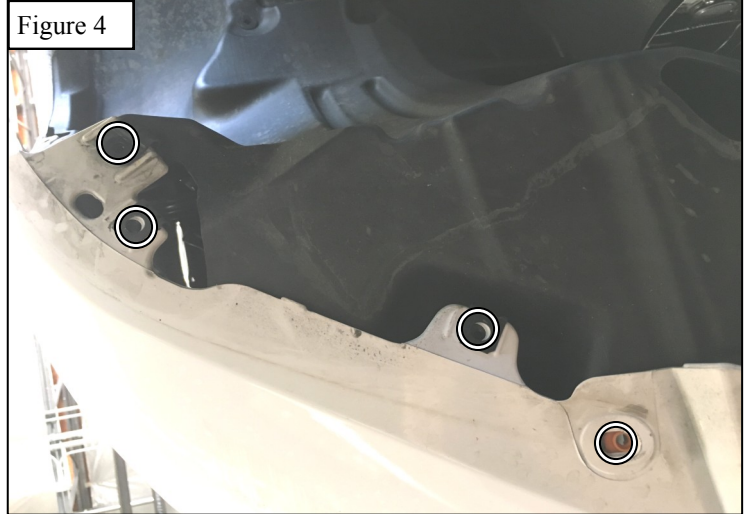

4. Remove valance by removing all fasteners holding it to the bottom of the bumper and wheel well liners. See **Figures 4 and 5.**

5. Remove all push pins fastening the bumper to the vehicle around the grille area and around head lights. Also, make sure to disconnect all wires and fog lights attached to the bumper.

Figure 5

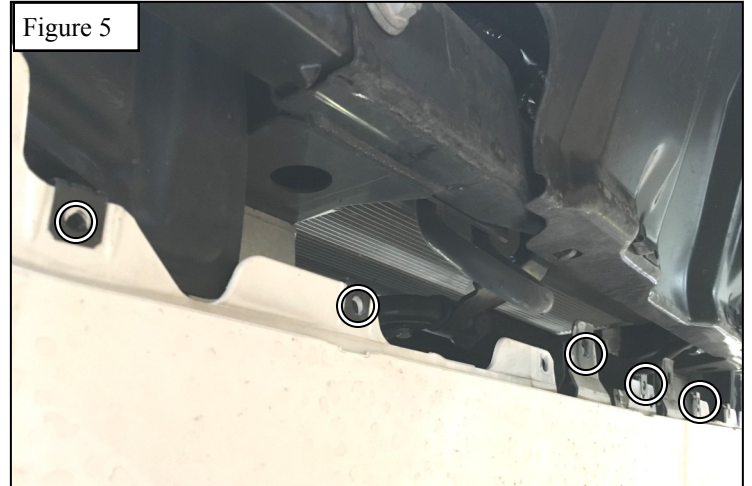
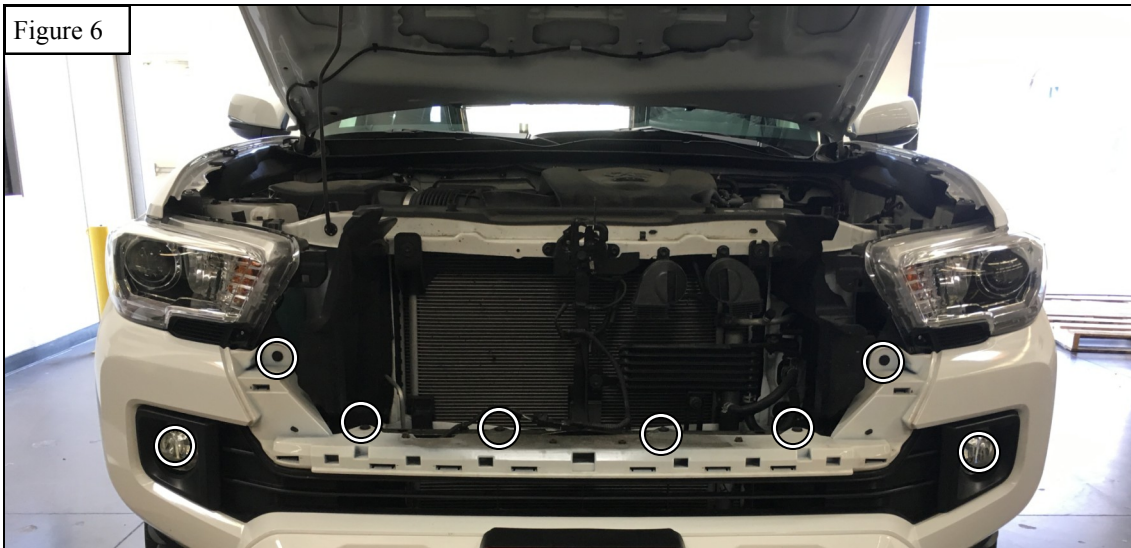

Figure 6



6. To remove bumper, it is recommended to seek assistance from a second person. Begin by pushing back wheel well plastic to expose a red push pin holding the bumper to a black plastic piece bolted to the metallic fender. See **Figure 7 and 8**.

Figure 7



Figure 8



7. Push red pin to allow black plastic piece to be separated from metallic fender See **Figure 8**, then using a pry tool, insert under tab to separate from bumper. Carefully separate the three tabs on each side of the truck. See **Figure 9**. When you completely detach one side, have someone hold the bumper for you to avoid damage on the other side. It is not necessary to unbolt black plastic piece from the fender. The bumper will be installed back again later after trimming.

Figure 9



8. Next, remove the aluminum bar attached to the frame of the vehicle using a 14MM socket or wrench. Remove by pulling firmly both sides at the same time. Save these nuts, they will be reused. See **Figure 10**.

Figure 10



TRIMMING INSTRUCTIONS

9. Lay the OEM bumper assembly on a flat table. You will need a ruler, tape, and a marker.
- a. Starting at the driver side of the bumper. Measure from the top corner down 1.75". Mark a dash at that point. See **Figure 11-12**

Fig. 11

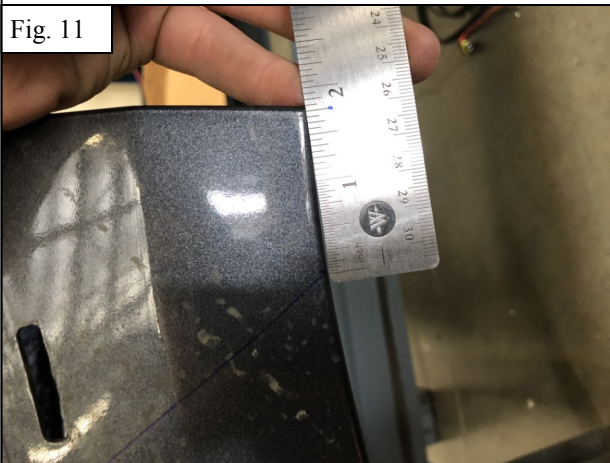

Fig. 12



- b. Using the ruler as a straightedge, draw a small line on the face of the bumper to the next edge. Using the ruler and line you just drew, measure 1 inch below the line. Mark dots at each edge. See **Figure 13-14**

Fig. 13

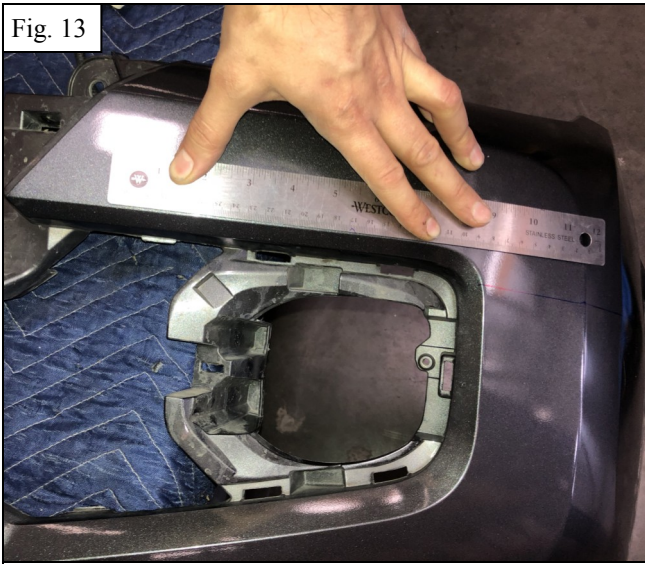
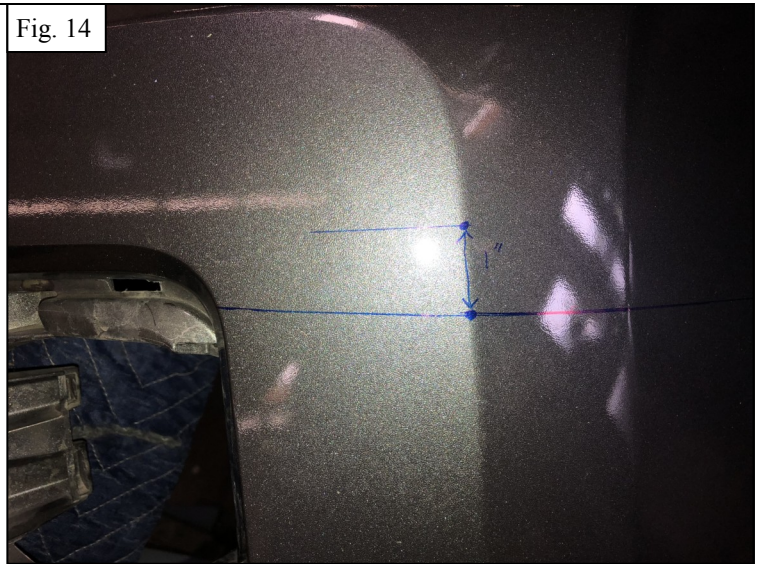

Fig. 14



- c. Using the ruler as a straightedge, connect the dots as seen in **Figure 14**.
- d. Moving to the upper edge of the bumper, measure down to the bottom line you drew. Verify that this measurement is 3.5". If it is not, then check your measurements and redraw the lines. If correct, then you are ready to cut. **See Figure 15**

Fig. 15



Passenger Side Shown

- e. Cut across the plastic as straight as possible, carefully using a very sharp knife or cutting tool.
- f. Repeat the process on the passenger side.
- g. Re-install the OEM bumper assembly and fender flares after trimming is complete. **See Figure 16 for example of trimmed bumper.**

Fig. 16



- h. Using the re-installed bumper as reference, lay a strip of tape parallel with the cut line on to the fender flare. Cut along this line. Repeat on passenger side. **See Figure 17.**

Fig. 17



- i. Use the provided rubber trim (11) to cover the cuts you just made.
- j. Trimming Procedure complete.



Westin Automotive Products, Inc.
320 W. Covina Blvd
San Dimas, Ca. 91773

Thank you for choosing Westin products
for additional installation assistance please call
Customer Service (800) 793-7846
www.westinautomotive.com

10. Unbolt the front oil cooler brackets.
11. Cut the driver side factory tow point flush with the frame
12. Locate the radiator relocation brackets. Using supplied M8 hardware, assemble the relocation brackets to the factory brackets on both sides. Slide the assembly back until the relocation bracket lines up with the original mounting location for the

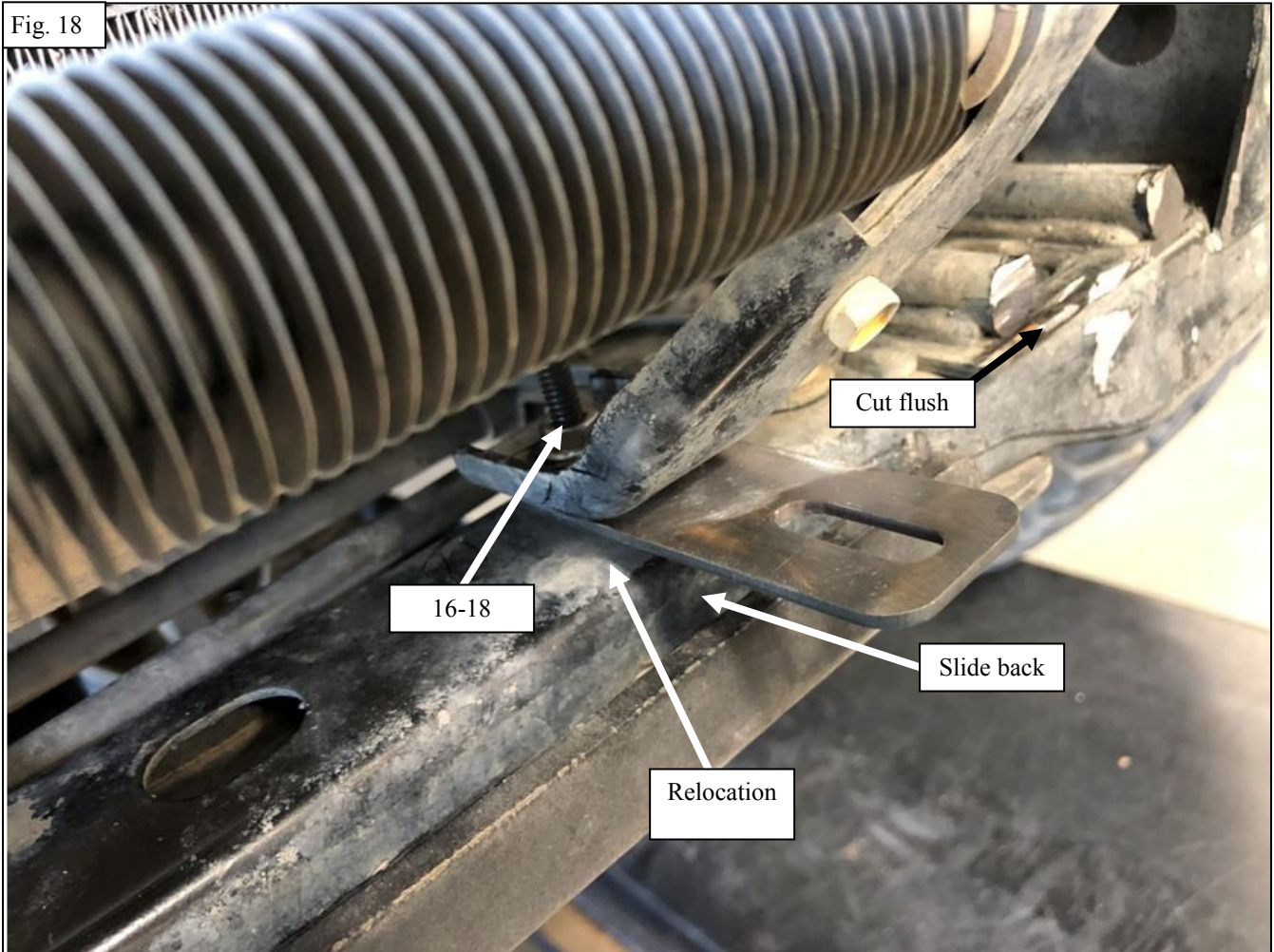

13. Locate the winch tray. Using supplied M12 hardware, loosely assemble the winch tray to the frame.
14. Locate the support brackets and using supplied M12 and factory hardware, loosely assemble to the frame and winch tray.

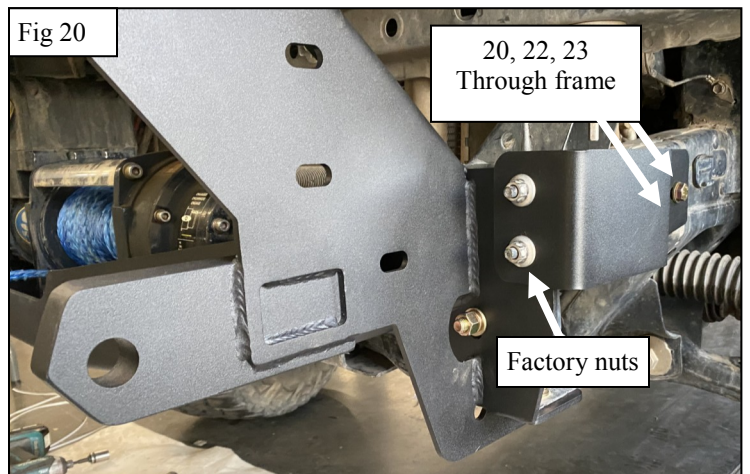
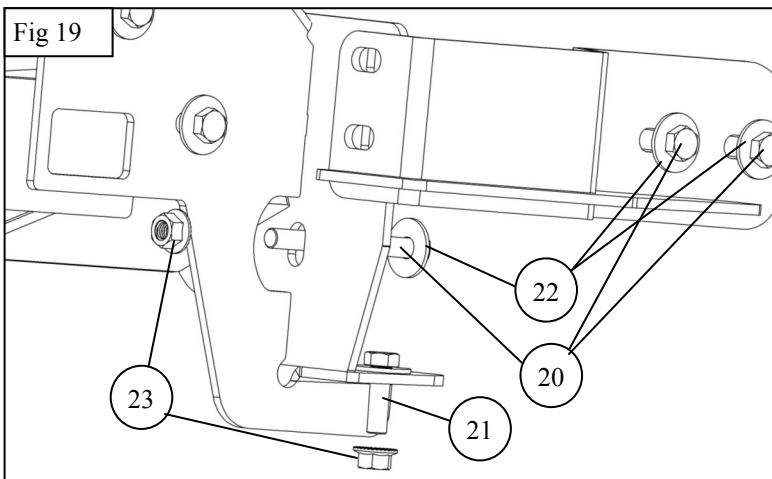

15. Using supplied M12 hardware, loosely assemble the main mounting brackets to the winch tray. See **Figure 21**

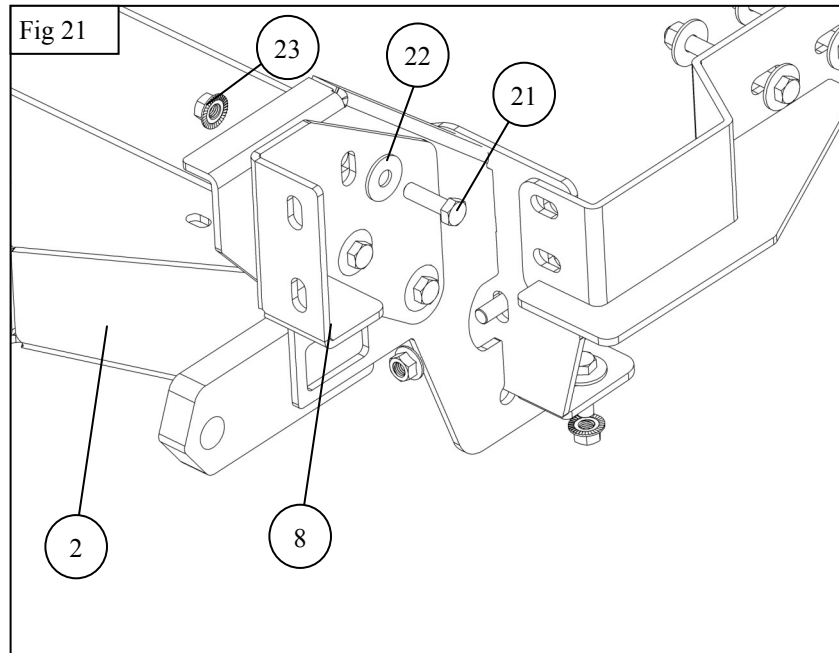

16. Mount your winch and winch accessories at this time.

17. If installing a light bar, install using the supplied LED light brackets and supplied M6 hardware, if applicable. Install light per manufacturers recommendation. See **Figure 22**

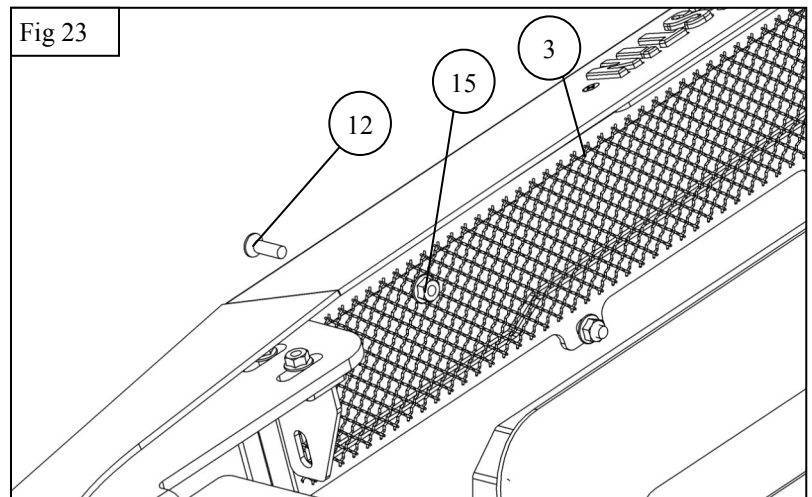
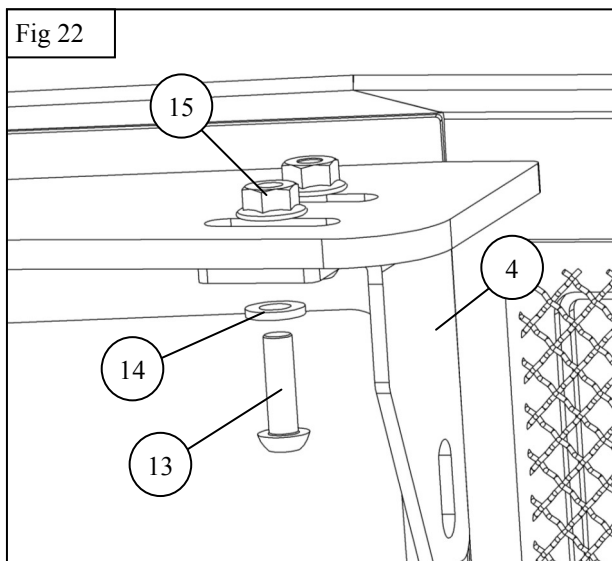

19. With help, loosely assemble the bumper assembly to the main mounting brackets using supplied M12 hardware. **See Figure 24**
20. Adjust as needed and tighten all hardware as specified: M6 to 5-7 ft-lbs, M8 to 15-18 ft-lbs, M12 to 50 ft-lbs.

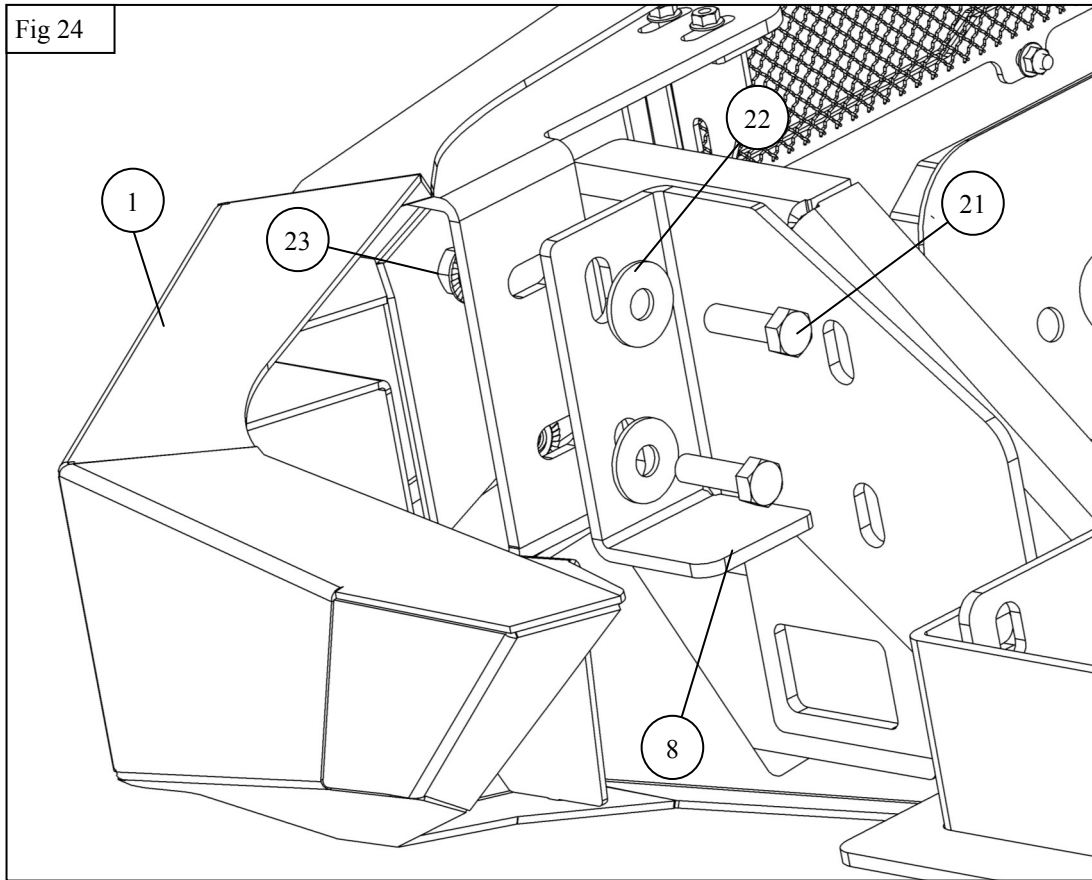

INSTALLATION COMPLETED



CARE INSTRUCTIONS

- REGULAR WAXING IS RECOMMENDED. DO NOT USE ANY TYPE OF POLISH OR WAX THAT MAY CONTAIN ABRASIVES.
- STAINLESS STEEL PRODUCTS CAN BE CLEANED WITH MILD SOAP AND WATER. STAINLESS STEEL POLISH SHOULD BE USED TO POLISH SMALL SCRATCHES.
- GLOSS BLACK FINISHES SHOULD BE CLEANED WITH MILD SOAP AND WATER.

WESTIN Westin Automotive Products, Inc.
320 W. Covina Blvd
San Dimas, Ca. 91773

Thank you for choosing Westin products
for additional installation assistance please call
Customer Service (800) 793-7846
www.westinautomotive.com



WARNING



Failure to follow these instructions could lead to death, personal injury, and / or property damage.

Failure to follow these instructions could lead to death, personal injury, and / or property damage.

FASTENERS:

All Westin supplied fasteners must be utilized and installed in accordance with the installation instructions and apply torque to the specifications as defined. **DOUBLE CHECK ALL FASTENERS BEFORE INITIAL USE, AND PERIODICALLY IN THE FUTURE TO ENSURE PROPER FUNCTION AND SAFETY.**

DRILLING:

Most Westin products do not require drilling for installation. If drilling is defined as required, use caution when drilling a vehicle. **FAILURE TO REVIEW AN AREA TO BE DRILLED MAY RESULT IN PERSONAL INJURY AND/OR INJURY TO OTHERS AS WELL AS VEHICLE DAMAGE.**

EYE PROTECTION:

ALWAYS WEAR SAFETY GLASSES OR GOGGLES DURING THE INSTALLATION PROCESS TO AVOID PERSONAL INJURY.

MAXIMUM TOWING/CARRYING CAPACITY: (if applicable)

The Westin Receiver Hitches will have a visible tow rating label affixed directly on the product. User should never exceed the vehicle manufacturers maximum tow and weight rating regardless of the capacity of the hitch. **FAILURE TO FOLLOW THESE GUIDELINES WILL VOID THE WESTIN WARRANTY AND MAY RESULT IN PERSONAL INJURY AND/OR INJURY TO OTHERS AS WELL AS VEHICLE DAMAGE.**

FOR CALIFORNIA RESIDENTS ONLY-PROP 65 WARNING:

Some products may contain chemicals such as DEHP, which can cause cancer, birth defects or other reproductive harm. For more info go to www.p65warnings.ca.gov



Westin Automotive Products, Inc.
320 W. Covina Blvd
San Dimas, Ca. 91773