

(866) 476-6276 / (866) IRONCROSS
www.ironcrossautomotive.com
4942 E. 66th St. N.
Tulsa, OK 74117
IRON CROSS AUTOMOTIVE INC. 2009

QTY.	PARTS LIST	QTY.	PARTS LIST	QTY.	PARTS LIST
1	Driver Front Bracket	4	3/8" Single Frame Lock Bolts	16	5/16"x3/4" Hex Bolts
1	Driver Rear Bracket	4	3/8" Double Frame Lock Bolts	16	5/16" Serrated Flange Nuts
4	Middle Brackets	12	3/8" Serrated Flange Nuts	8	Bracket Clamps
1	Passenger Front Bracket	8	3/8" Plastic Washers		
1	Passenger Rear Bracket				

- STEP 1** Remove contents from box and check for damaged parts. Verify all parts are present, making sure to read and understand instructions before installation.
- STEP 2** Locate factory running board mount locations on bottom side of the cab. **Regular Cabs have 2 mount locations; Quad Cabs and Crew Cabs have 4.**
- STEP 3** Install double frame lock bolts into the body panel at the 2 raised islands through the factory punched holes as shown in illustration. Install single frame lock bolts into (2) middle locations as in illustration. Thread plastic washer onto frame lock bolt to ensure bolt does not fall into body panel.
- STEP 4** When installing the FRONT and REAR brackets, first thread top of the bracket onto the upper single frame lock bolts and then the bottom of the bracket to the double frame lock bolts.
- STEP 5** Thread 3/8" flange nuts onto frame lock bolts. Tighten all bolts for final installation and proceed to reverse side of sheet to install your ENDEAVOUR boards.

DRIVER REAR BRACKET

DRIVER MIDDLE BRACKETS x (2)

DRIVER FRONT BRACKET

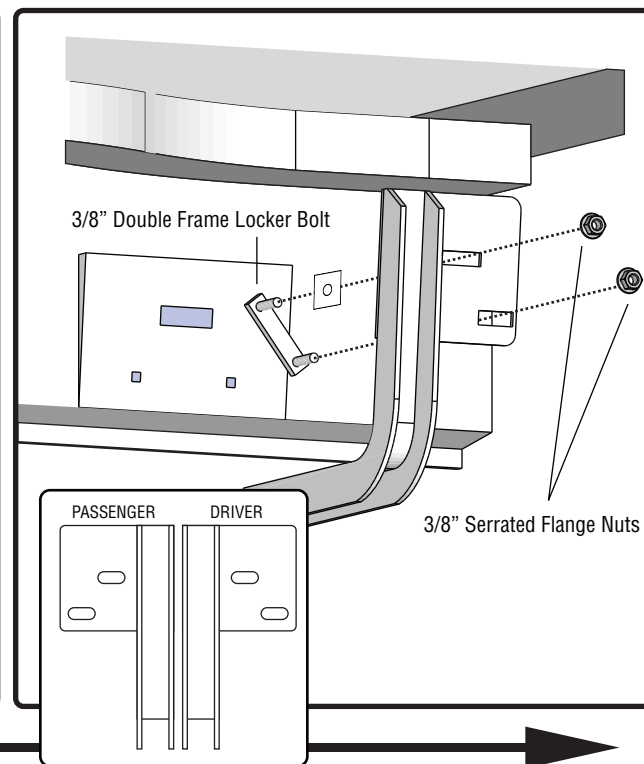
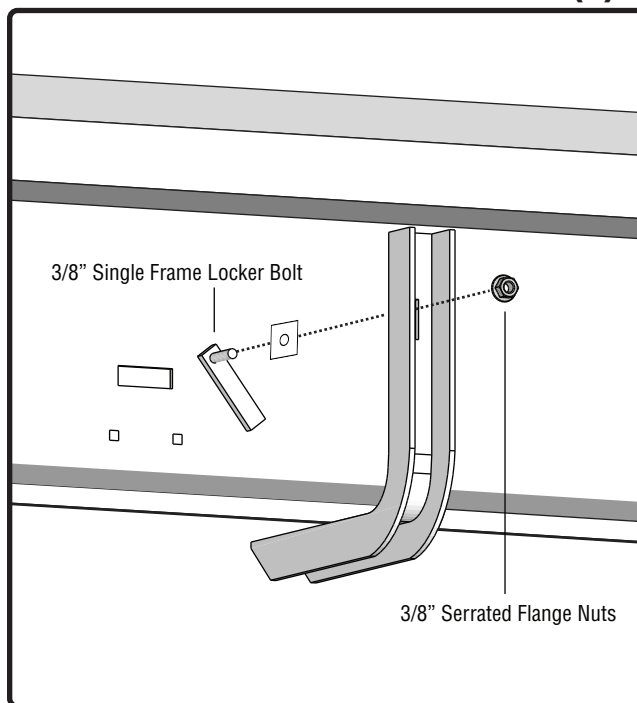
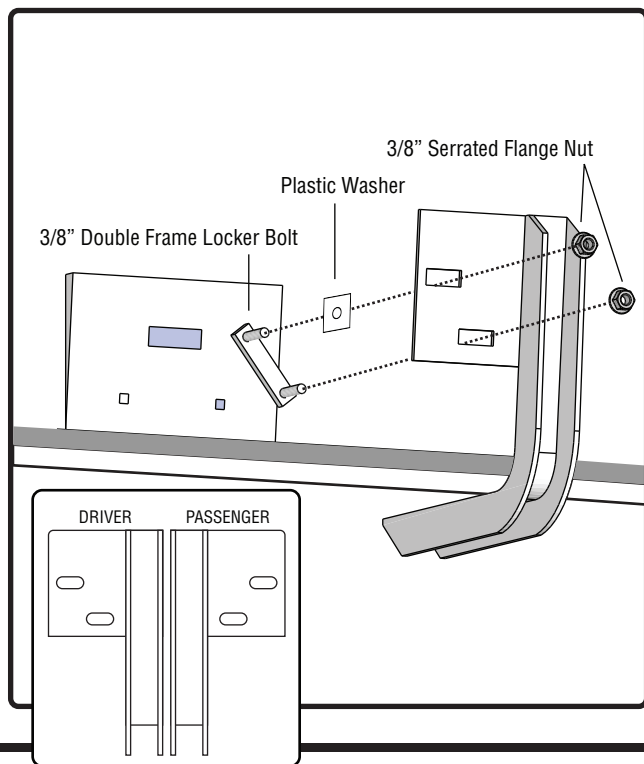

VEHICLE FRONT

Mounting board to vehicle.

1) Place clamp brackets on main bracket and turn 90 degrees to the main brackets. Place carriage bolt through top of bracket clamp in oblong hole and center hole in main bracket, placing serrated flange nut on bottom side (**Fig 1a**).

2) Place running board on main brackets, making sure that opening and the bottom of the board goes over the clamp brackets.

3) Rotate clamp brackets above main brackets, making sure that both edges of the running board are in between the clamp bracket and the main bracket. Install 5/16" hex bolt through center hole of bracket clamp and oblong hole of main bracket, placing flat washer and nylock on bottom side (**Fig 1b**).

4) Adjust board to be centered under the cab of the vehicle and tighten the clamp brackets to the main brackets. Make sure all remaining hardware is tightened and test the running boards for attachments.

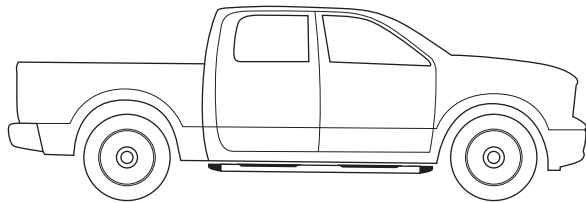

2009 DODGE RAM

FRAME LOCK BOLT INSTALL

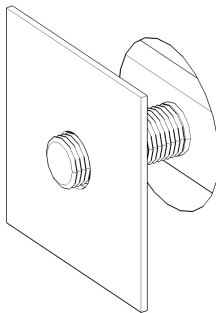

1. Un-thread plastic washer a 1/2" inch from bolt.
2. Slide frame lock into hole.
3. Thread plastic washer onto bolt until tight to secure frame lock bolt from falling into hole.

IRON CROSS AUTOMOTIVE INC.

Iron Cross Automotive INC. 2008

MOUNTING BOARD TO BRACKET

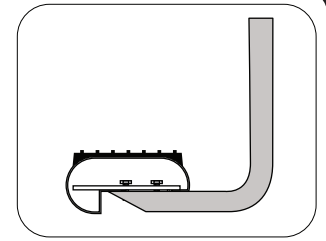

FIG 2a

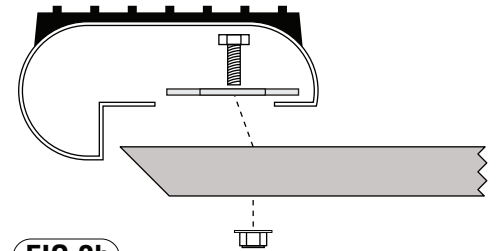
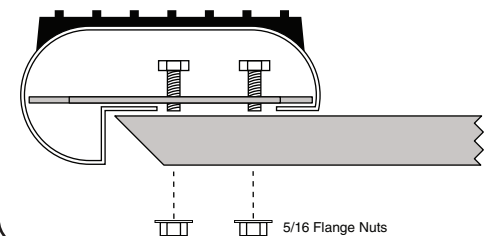
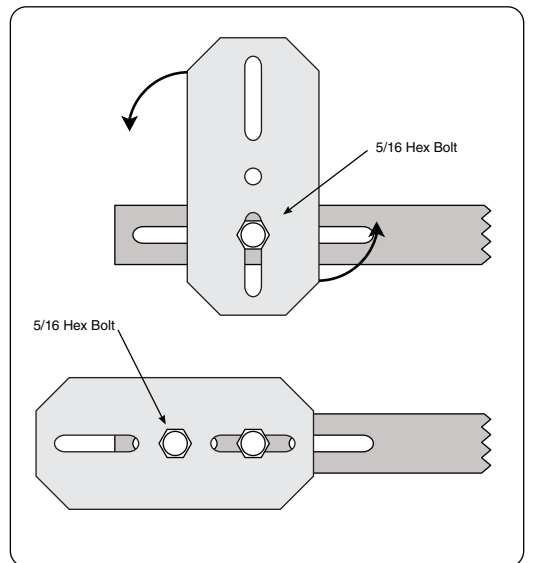

FIG 2b TOP VIEW



Supplemental Bracket Instructions

(Factory inserts install in hex holes)
for most 2015 to 2019 models

92-638

INSTALLATION PACKAGE

3/8" Single Frame Locker	4
8mm x 20mm Bolts	4

Necessary Tools

Combination wrench set with 1/2" and 13mm sockets
Safety glasses

STEP 1: Make sure you have received all items listed above. Some vehicles have come from the manufacturer with inserts installed in the lower 2 hex shaped holes shown in Fig A & B. You will not use the 5/16 double studded bolt plates included in the standard bracket kit 99-638 if you have these inserts installed in your vehicle. Please discard.

STEP 2: Install 3/8" single frame locker in upper oval hole as shown Fig C use plastic retainer to hold plate in place while installing bracket. Make sure bolt plate is resting on lower edge of oval hole after installation.

STEP 3: Place bracket over bolt plate. There will be no stud as shown in lower hole in Fig D. Refer to Step 3 on original instruction for different board height placement in lower or upper slots in bracket.

STEP 4: After board height has been selected use washer and 3/8" serrated nut from original installation kit on stud and washer with supplied 8mm bolt into factory insert to complete bracket installation. These steps will be used in both front and middle bracket mounting locations.

STEP 5: Check all bolts to verify completed mounting and tightness. Installation is complete

STEP 6: Factory bracket on Driver side front must be removed on 2015 and up models.

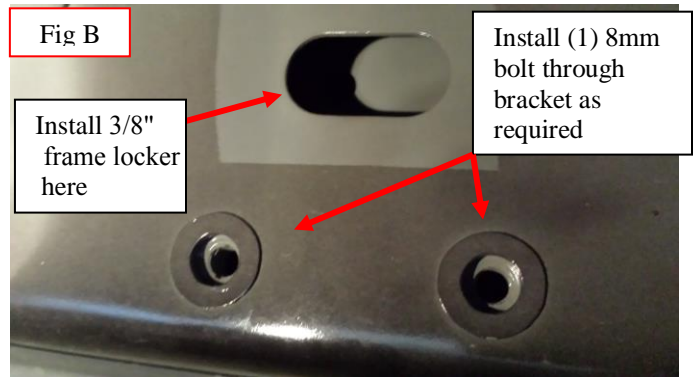

This stud will be replaced with 8mm bolt and washer into factory insert shown in Fig B