

EZ Bronco Flip Top - 2 Panel

EZTRUNK™ ASSEMBLY

MANUAL

#5121 7242

MAKE IT EZ

Print the latest manual
Scan QR CODE for PDF MANUALS



Scan QR CODE
for Video MANUALS

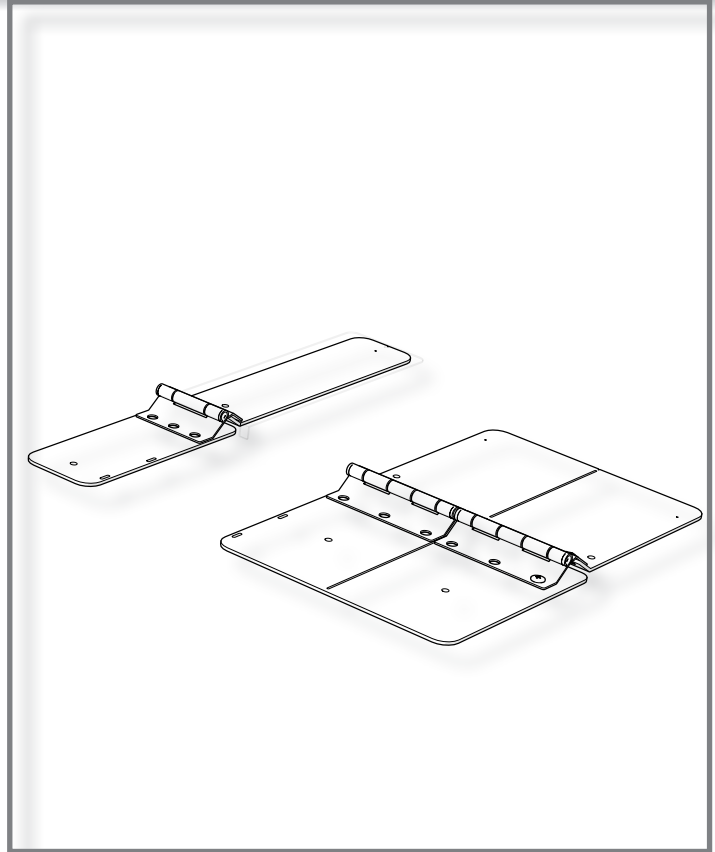

Customer Service

Any question? WE ARE HERE TO HELP!

Text or Call 203-901-0055 / Call 203-591-9060





EMAIL US: SERVICE@EZTRUNK.NET

7 days a week 8:30 am EST

WE CAN HELP YOU!

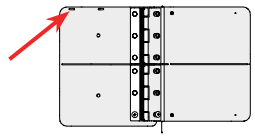
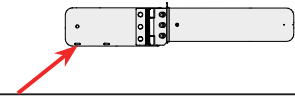
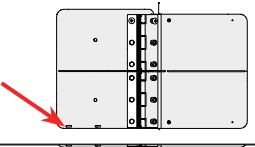
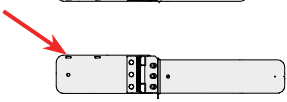
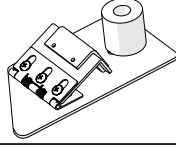
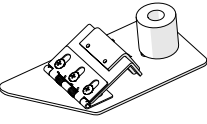
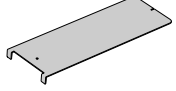
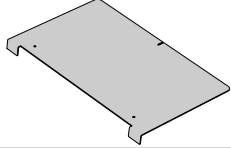
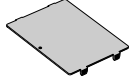
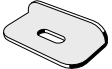
PO#:

Please read instructions fully before beginning assembly

NO	Illustration	Description	Part#	QTY
1		Driver / Left Freedom Top Hinge - Wide	51214201	1
2		Driver / Left Freedom Top Hinge - Narrow	51214202	1
3		Passenger / Freedom Top Right Hinge - Wide	51214203	1
4		Passenger / Freedom Top Right Hinge - Narrow	51214204	1
5		Lock Kit - Drive	51214205	1
5		Lock Kit - Passenger	51214206	1
6		Alignment Template - Narrow	51214207	1
7		Alignment Template - Wide	51214208	1
8		Locking Plate	51214209	1
9		Corner Plate	51214210	2
10		Primer 94-10	PM9410	1
11		Lock Nut M6	10062	24+2 extra
12		Rubber Washer	06012	24+2 extra
13		Metal Washer	16012	30+2 extra

NO	Illustration	Description	Part#	QTY
14		Bolt with Washer M6x20 (0.75")	063202	12
14		Bolt with Washer M6x35 (1.37")	063352	4
15		Bolt with Washer M6x40 (1.57")	063402	2
16		Bolt M6x60 (2.35")	063602	2
17		Bolt M6x65 (2.55")	063652	2
18		Bolt M6x70 (2.75")	063702	2
19		Plastic Nut Cap	P10062	26
20		#10 & #13 Wrench	#10	1
21		Allen Wrench #4	AW4	1
22		Drill Bit	#6	1

RECOMMENDED TOOLS



#2 Phillips Screw Driver



Paper Tape

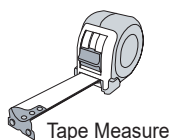

Tape Measure

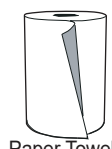

Paper Towel



Drill

WARNING

EZFreedom Flip Top Hinge is designed to be installed on a roof with a factory finish, the product has not been tested on after-market finishes. The product warranty is void if the EZFreedom Flip Top Hinge is installed on a roof with any modifications or changes to the finish.

Wash and dry roof prior to installation concentrating on the hinge location area.

Ambient temperature should be at least **70F** for proper adhesion of the EZFreedom Flip Top Hinge.

Please allow the Freedom Top Hinge to cure 24 hours before use.

WARNING This product is intended to provide added "off-road" convenience and utility to your vehicle. This product is not intended to provide occupant containment or protection in the event of an accident or rollover. Further, "on road" use may involve increased risk of serious injury in the event of side-impact accidents. To reduce risk from these types of injuries: Always wear seat belt and shoulder harness for all vehicle occupants. Keep arms and body inside vehicle. Drive safely, read and understand all manufacturers warnings and product instructions before installation. Periodically check and adjust all latches and fasteners, Failure to do so could result in the doors not latching securely.

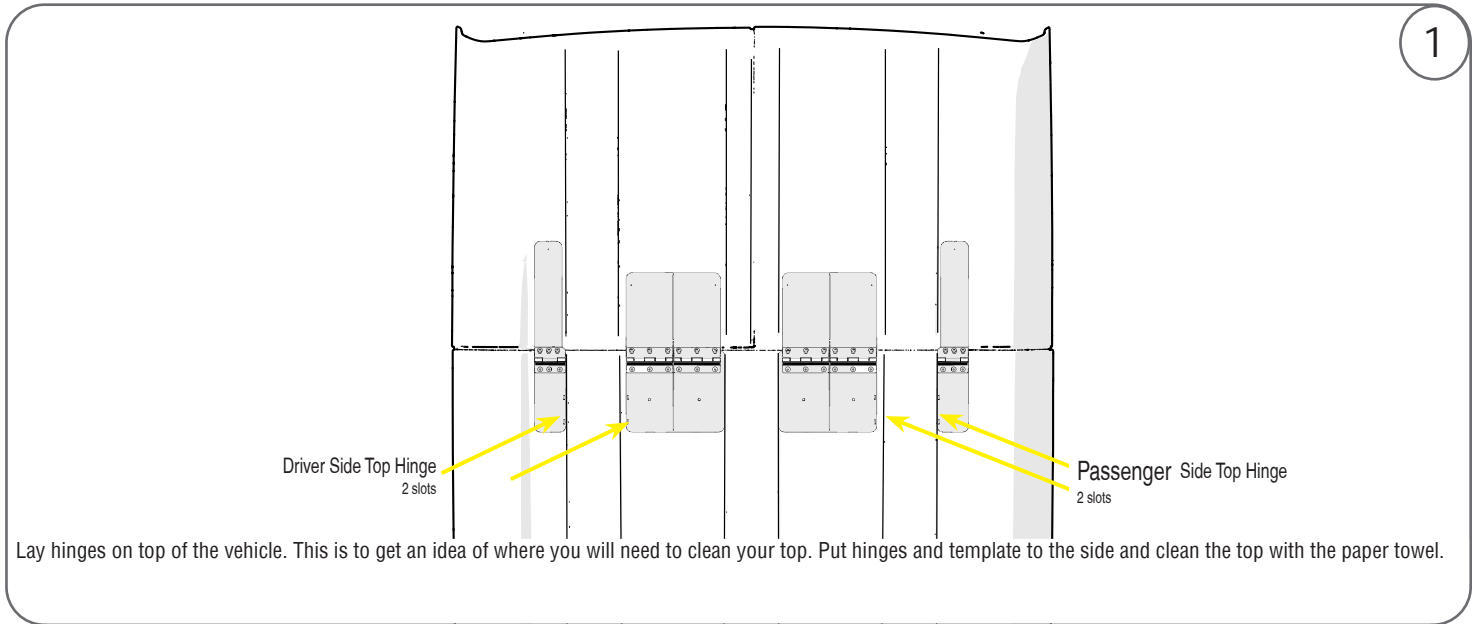

Lay hinges on top of the vehicle. This is to get an idea of where you will need to clean your top. Put hinges and template to the side and clean the top with the paper towel.

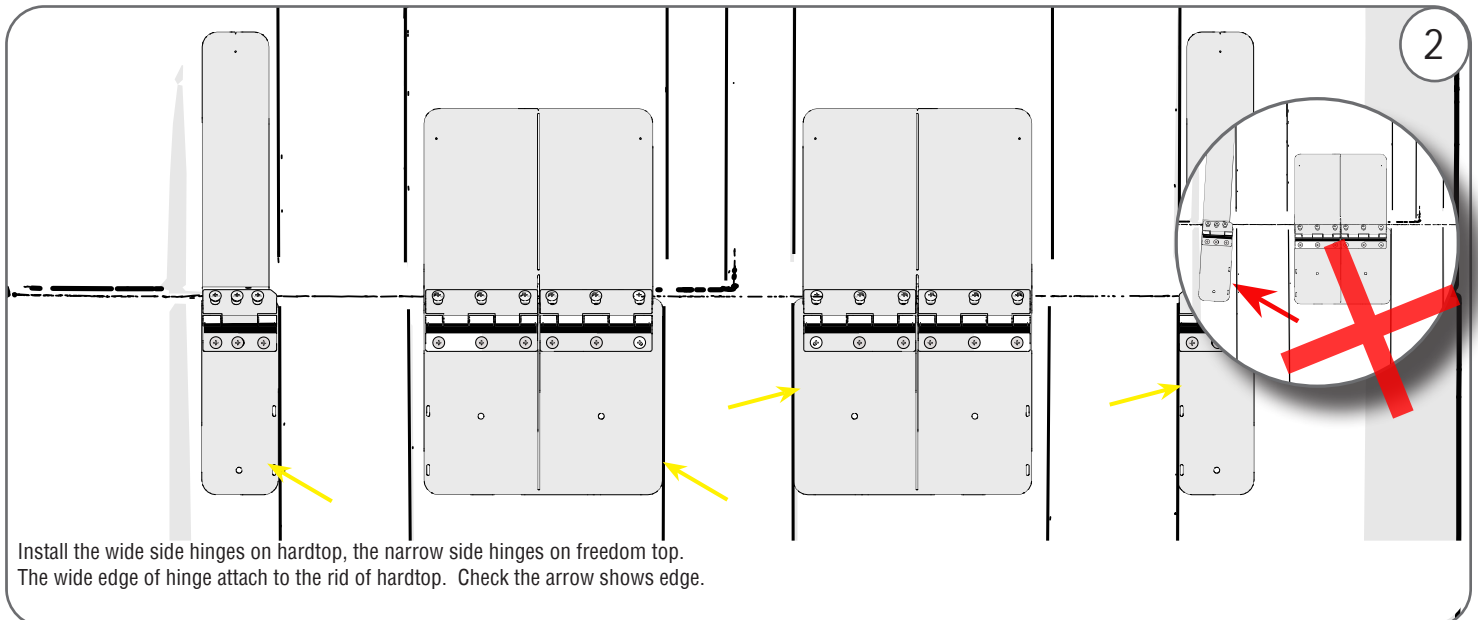

Install the wide side hinges on hardtop, the narrow side hinges on freedom top. The wide edge of hinge attach to the rid of hardtop. Check the arrow shows edge.

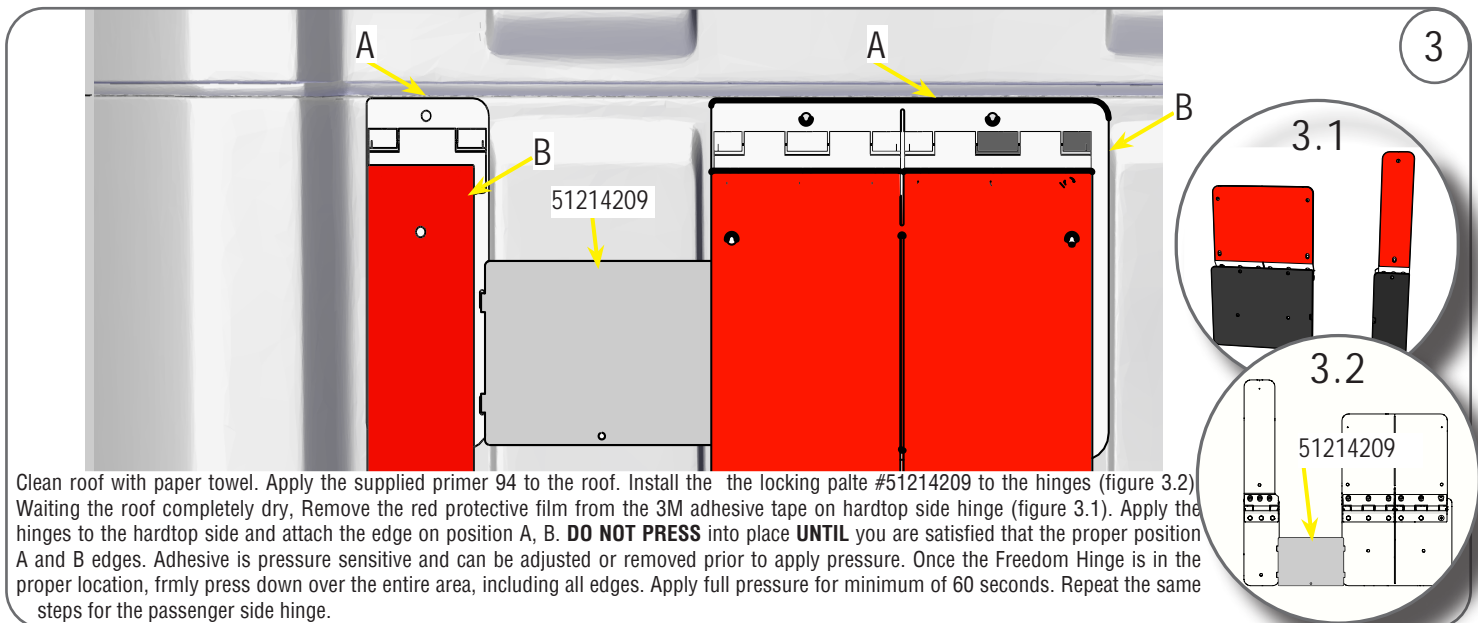

Clean roof with paper towel. Apply the supplied primer 94 to the roof. Install the the locking palte #51214209 to the hinges (figure 3.2) Waiting the roof completely dry, Remove the red protective film from the 3M adhesive tape on hardtop side hinge (figure 3.1). Apply the hinges to the hardtop side and attach the edge on position A, B. **DO NOT PRESS** into place **UNTIL** you are satisfied that the proper position A and B edges. Adhesive is pressure sensitive and can be adjusted or removed prior to apply pressure. Once the Freedom Hinge is in the proper location, frmly press down over the entire area, including all edges. Apply full pressure for minimum of 60 seconds. Repeat the same steps for the passenger side hinge.

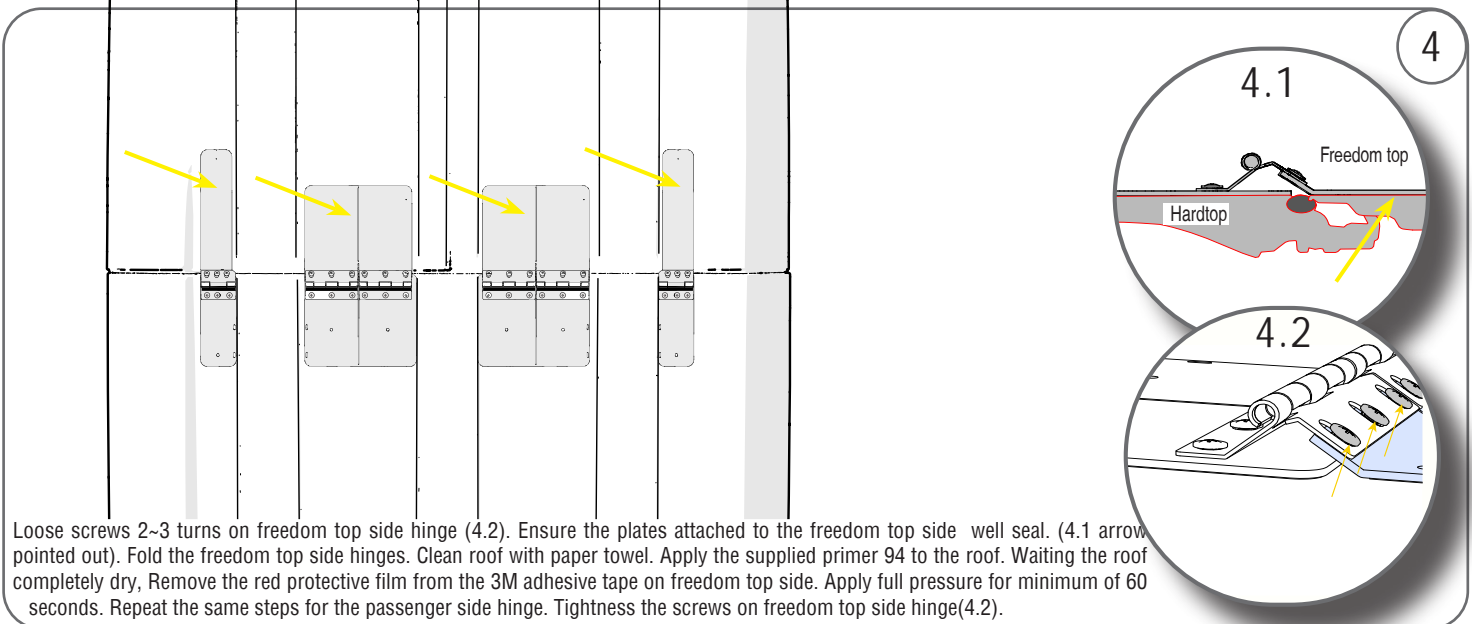

4

4.1
Freedom top
Hardtop

4.2

Loose screws 2~3 turns on freedom top side hinge (4.2). Ensure the plates attached to the freedom top side well seal. (4.1 arrow pointed out). Fold the freedom top side hinges. Clean roof with paper towel. Apply the supplied primer 94 to the roof. Waiting the roof completely dry, Remove the red protective film from the 3M adhesive tape on freedom top side. Apply full pressure for minimum of 60 seconds. Repeat the same steps for the passenger side hinge. Tightness the screws on freedom top side hinge(4.2).

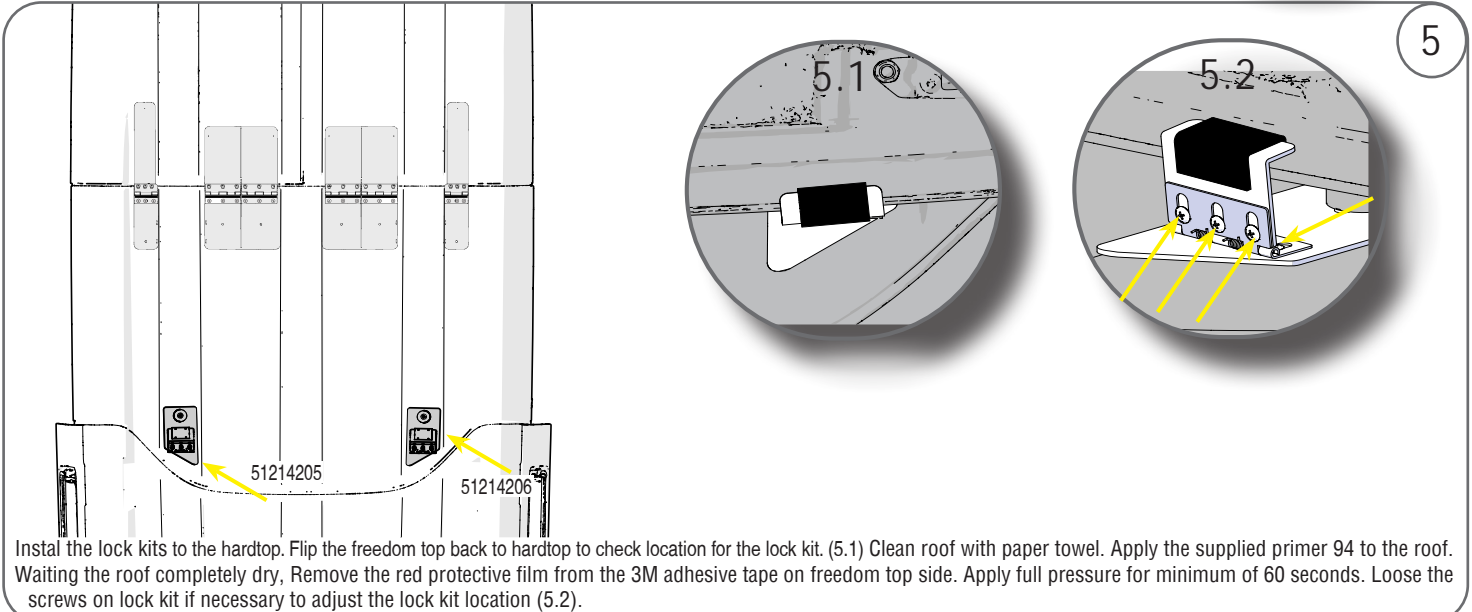

5

5.1

5.2

51214205
51214206

Instal the lock kits to the hardtop. Flip the freedom top back to hardtop to check location for the lock kit. (5.1) Clean roof with paper towel. Apply the supplied primer 94 to the roof. Waiting the roof completely dry, Remove the red protective film from the 3M adhesive tape on freedom top side. Apply full pressure for minimum of 60 seconds. Loose the screws on lock kit if necessary to adjust the lock kit location (5.2).

Extra Security Bolt version

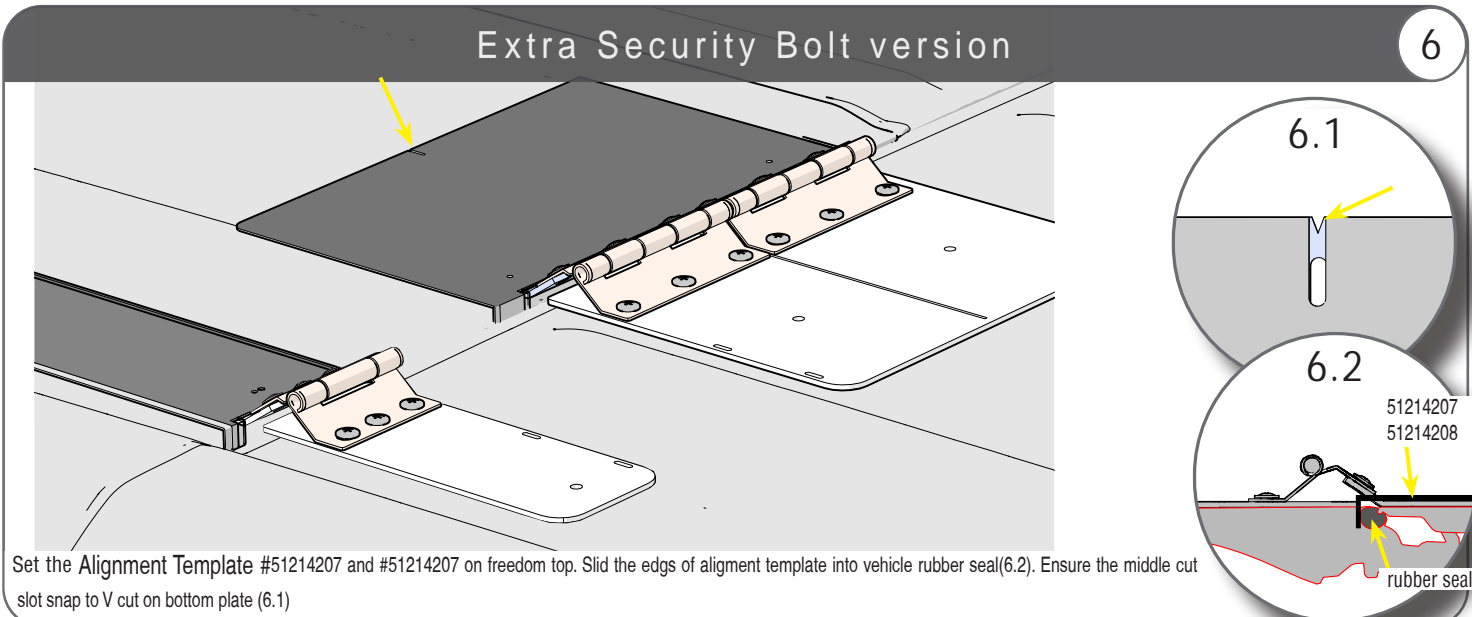

6

6.1

6.2
51214207
51214208
rubber seal

Set the Alignment Template #51214207 and #51214207 on freedom top. Slid the edges of alignment template into vehicle rubber seal(6.2). Ensure the middle cut slot snap to V cut on bottom plate (6.1)

7

Use the supplied drill bit make the holes for M6 (1/4") bolts, Drill holes on driver and passenger side.

8

Driver side

Install the bolts location and length follow the drawing. Location #4, #5 and #6 need to flip the freedom top to find the bolt hole. Repeat the bolts installation on passenger side hinge. The bolts and washer details check next step.

9

Bolt with Washer

Install the bolts location #1, #2, #3, #7, #8 and #9 follow this details.

10

Round Head Bolt

Install the bolts location #4 and #5 follow this details.

11

Bolt with Washer #6

Install the bolts location #6 follow this details.

12

Bolt with Washer #6

Install the corner plate under hardtop.

Customer Service

Any question? WE ARE HERE TO HELP!

Text or Call 203-901-0055 / Call 203-591-9060

EMAIL US: SERVICE@EZTRUNK.NET

7 days a week 8:30 am EST

WE CAN HELP YOU!

EZ Bronco Flip Top & Rack (3) Panel

EZTRUNK™ ASSEMBLY

MANUAL

5121 7343

MAKE IT EZ

Print the latest manual
Scan QR CODE for PDF MANUALS



Scan QR CODE
for Video MANUALS

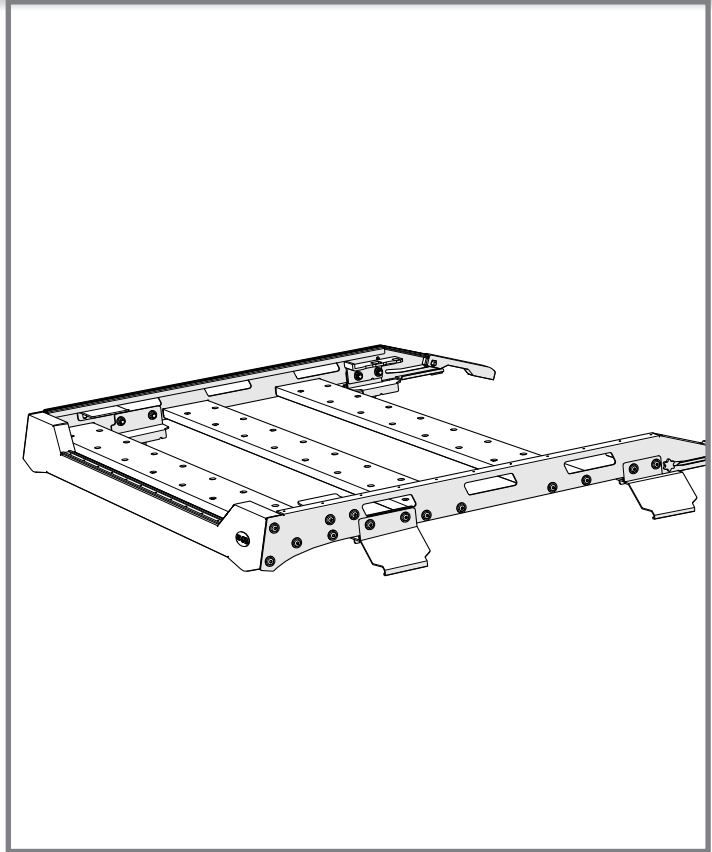

Customer Service

Any question? WE ARE HERE TO HELP!

Text or Call **203-901-0055** / Call **203-591-9060**









EMAIL US: SERVICE@EZTRUNK.NET

7 days a week 8:30 am EST

WE CAN HELP YOU!

PO# :

Please read instructions fully before beginning assembly

NO	Illustration	Description	Part#	QTY.
1		Driver Side Rail	5121 4301	1
2		Passenger Side Rail	5121 4302	1
3		Driver Side Front Bracket - Outer	5121 4303	1
4		Driver Side Front Bracket - Inner	5121 4304	1
5		Driver Side Front Bracket - Top	5121 4305	1
6		Driver Side Rear Bracket - Outer	5121 4306	1
7		Driver Side Rear Bracket - Inner	5121 4307	1
8		Side Rail Rear Bracket -Top	5121 4308	2
9		Passenger Side Front Bracket - Outer	5121 4309	1
10		Passenger Side Front Bracket - Inner	5121 4310	1
11		Passenger Side Front Bracket -Top	5121 4311	1
12		Passenger Side Rear Bracket-Outer	5121 4312	1
13		Passenger Side Rear Bracket - Inner	5121 4313	1
14		Cross bar	5121 4314	3
15		Rear fairing	5121 4315	1
16		Washer Plate	5121 4316	10
17		Stopper Plate	5121 4317	2
18		Bolt 8x30 (1. 18"	8302	4
19		Bolt 8x20 (0.78"	8202	24
20		Washer	1 5801	44 + 2 extra
21		Lock Nut	1 0082	16 + 1 extra
22		#10 & #13 Wrench	#1013	1
23		#5 Allen Wrench	#5	1

1

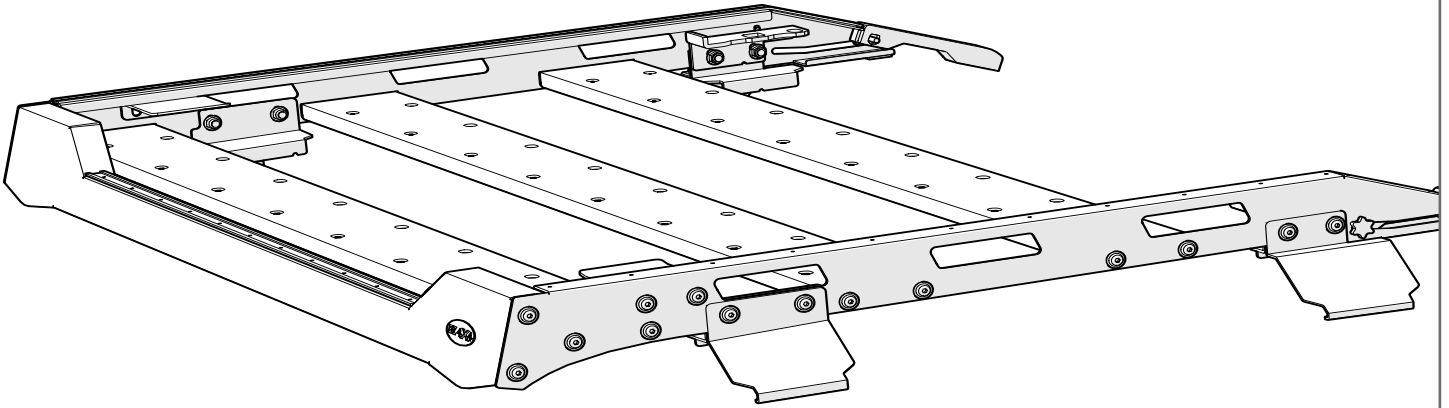

2

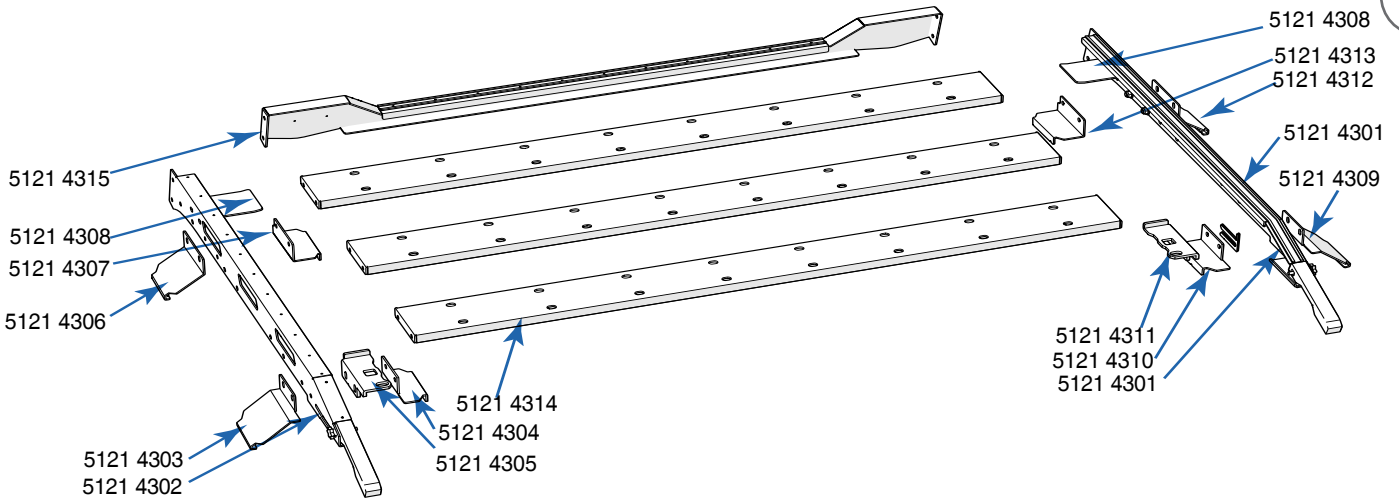

3

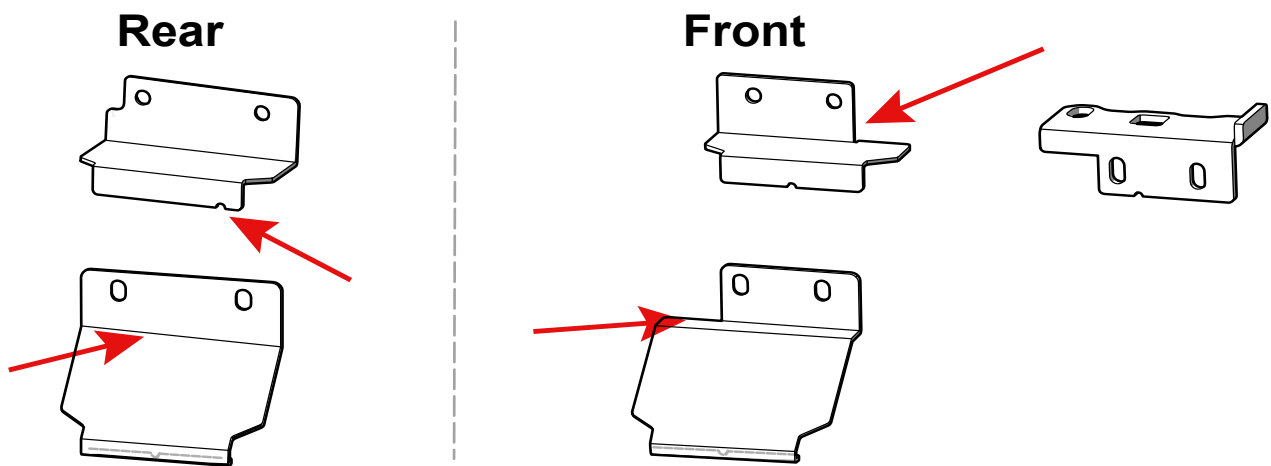

Driver Side Brackets
Bottom edge with 1 cut off marks

4

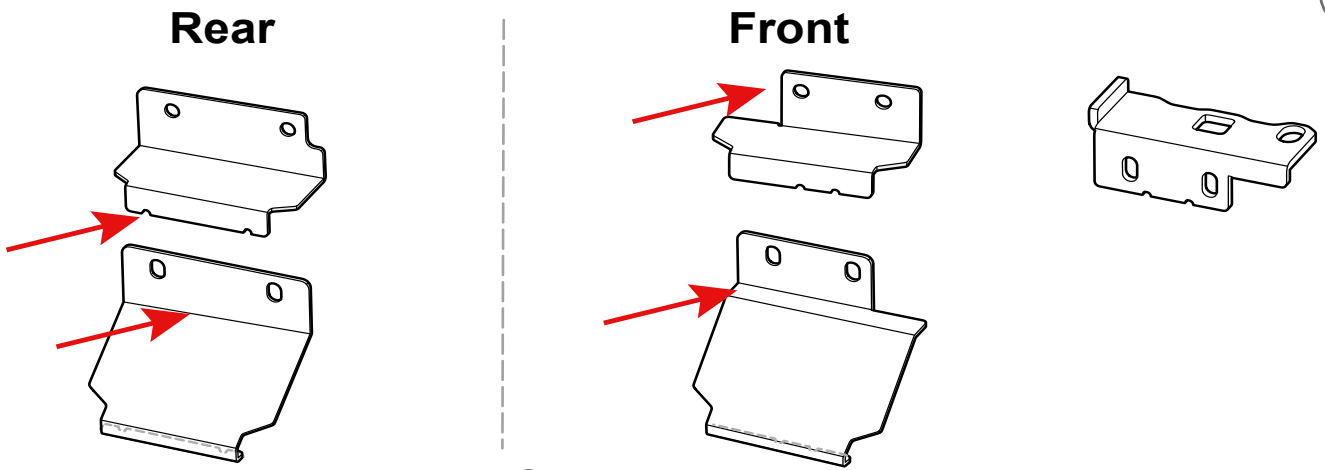

Passenger Side Brackets
Bottom edge with 2 cut off marks

5

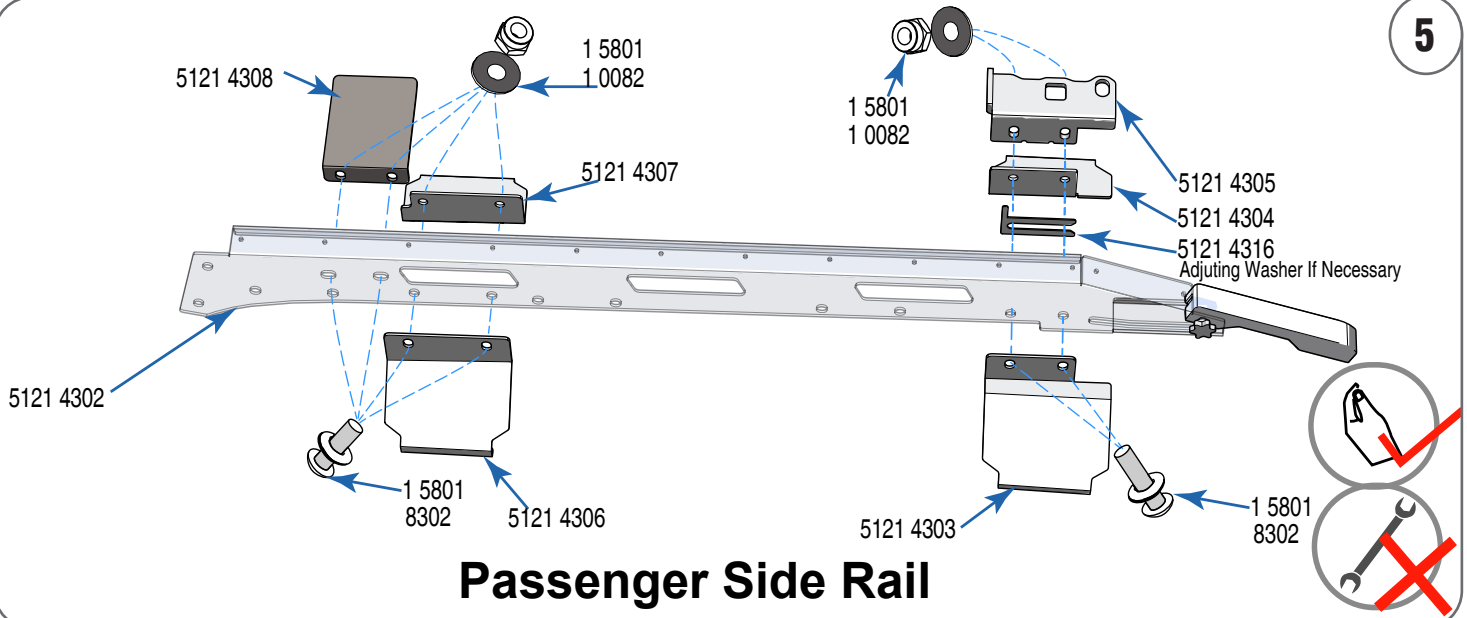

Passenger Side Rail

6

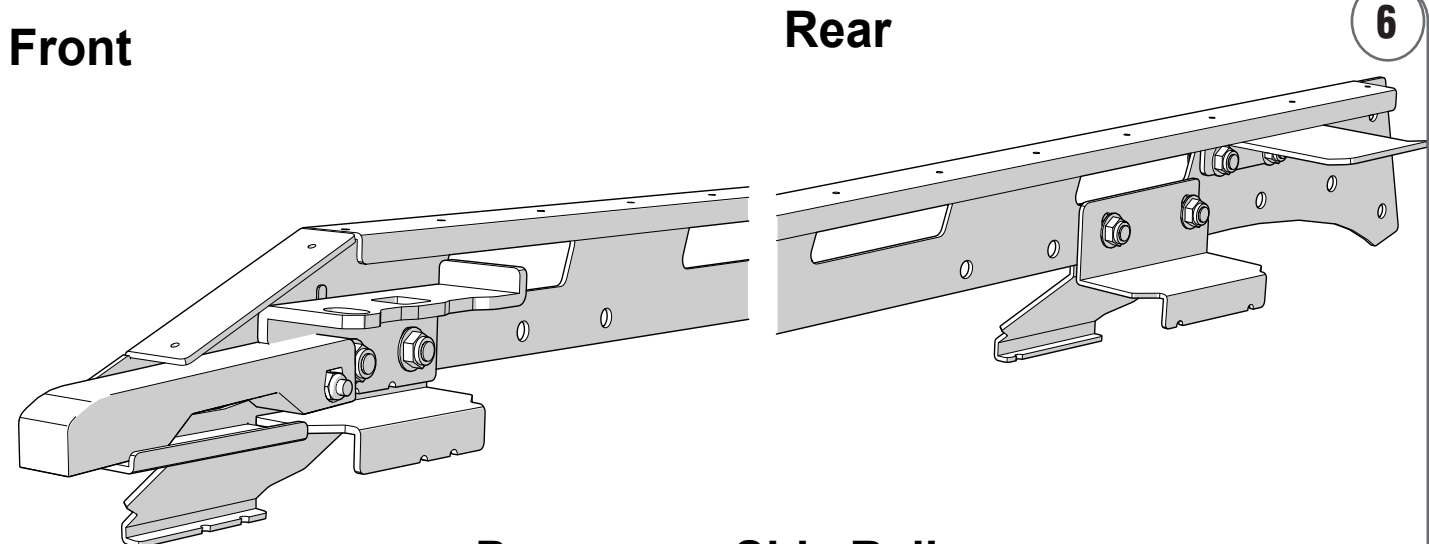

Passenger Side Rail

BEFORE BEGINNING, SEE THE ASSEMBLY INSTRUCTION VIDEO ON EZTRUNK.NET

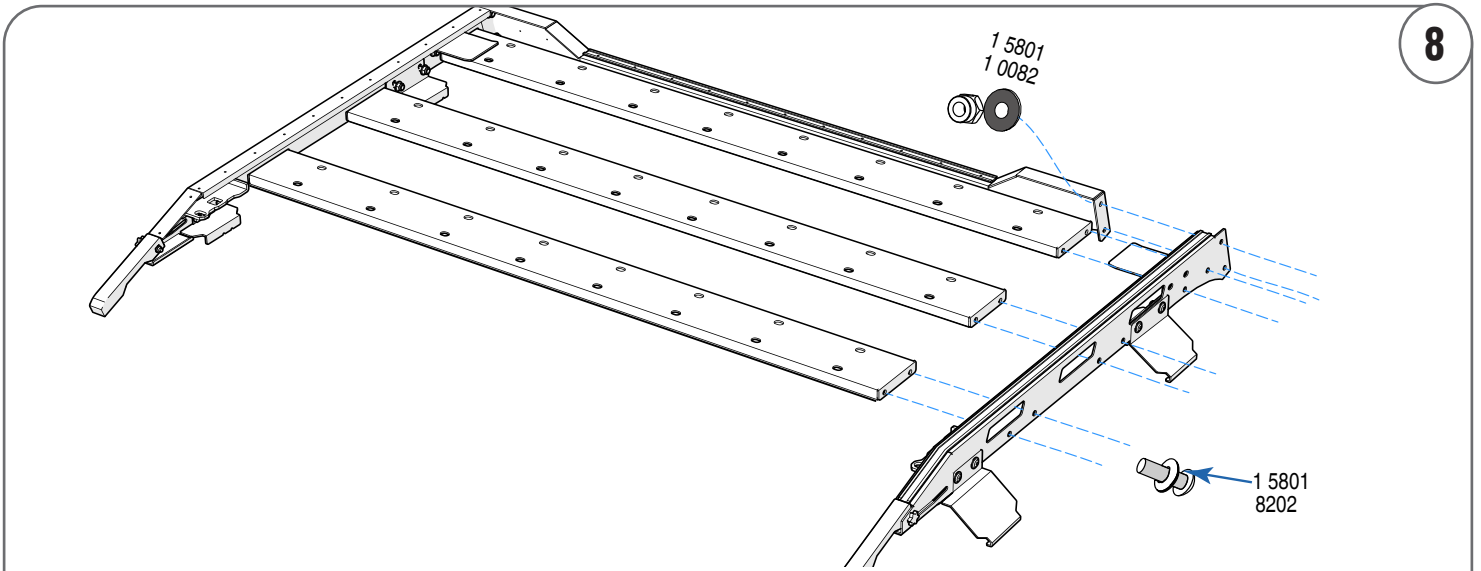
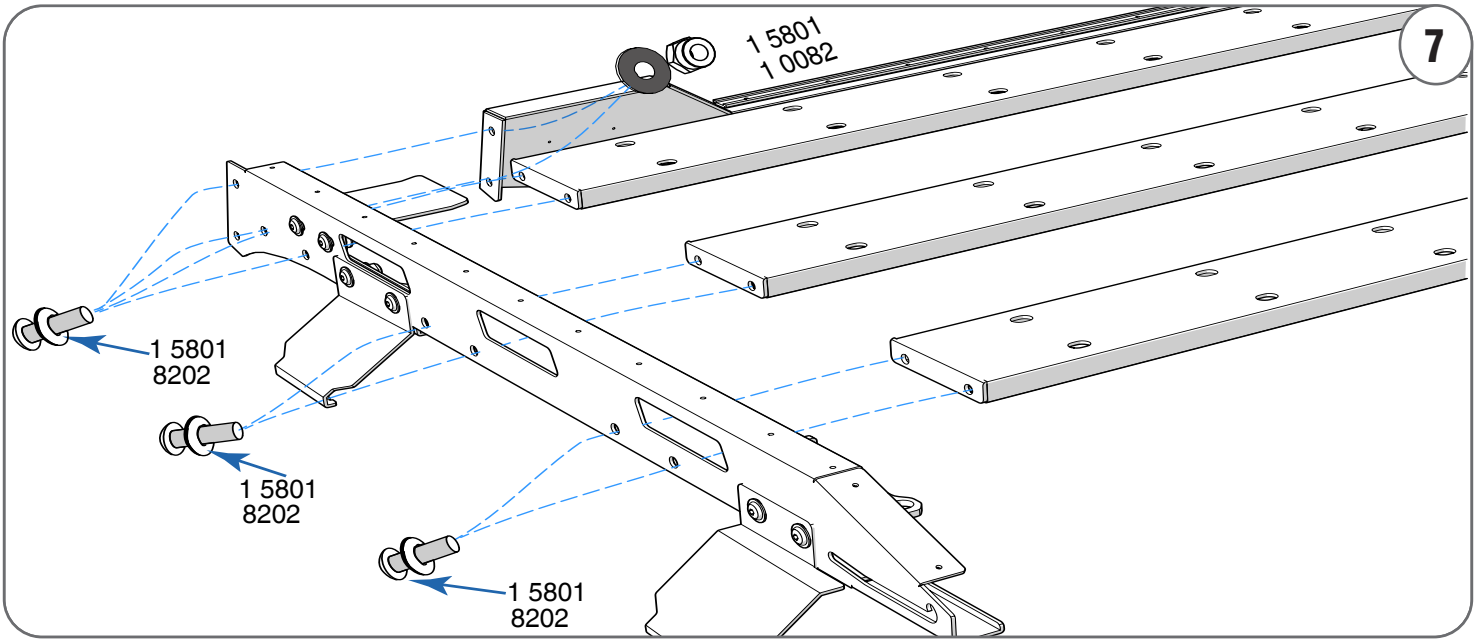

Put the EZ roof rack into your vehicle. Install the passenger side rail and snap the bracket into the groove on the roof.



Customer Service

Any question? WE ARE HERE TO HELP!

Text or Call 203-901-0055 / Call 203-591-9060

EMAIL US: SERVICE@EZTRUNK.NET

7 days a week 8:30 am EST

WE CAN HELP YOU!