

APPLICATION
Toyota Tacoma

MODEL YR
2024 - 2026

PART #
76362-01A

INSTALLATION GUIDE

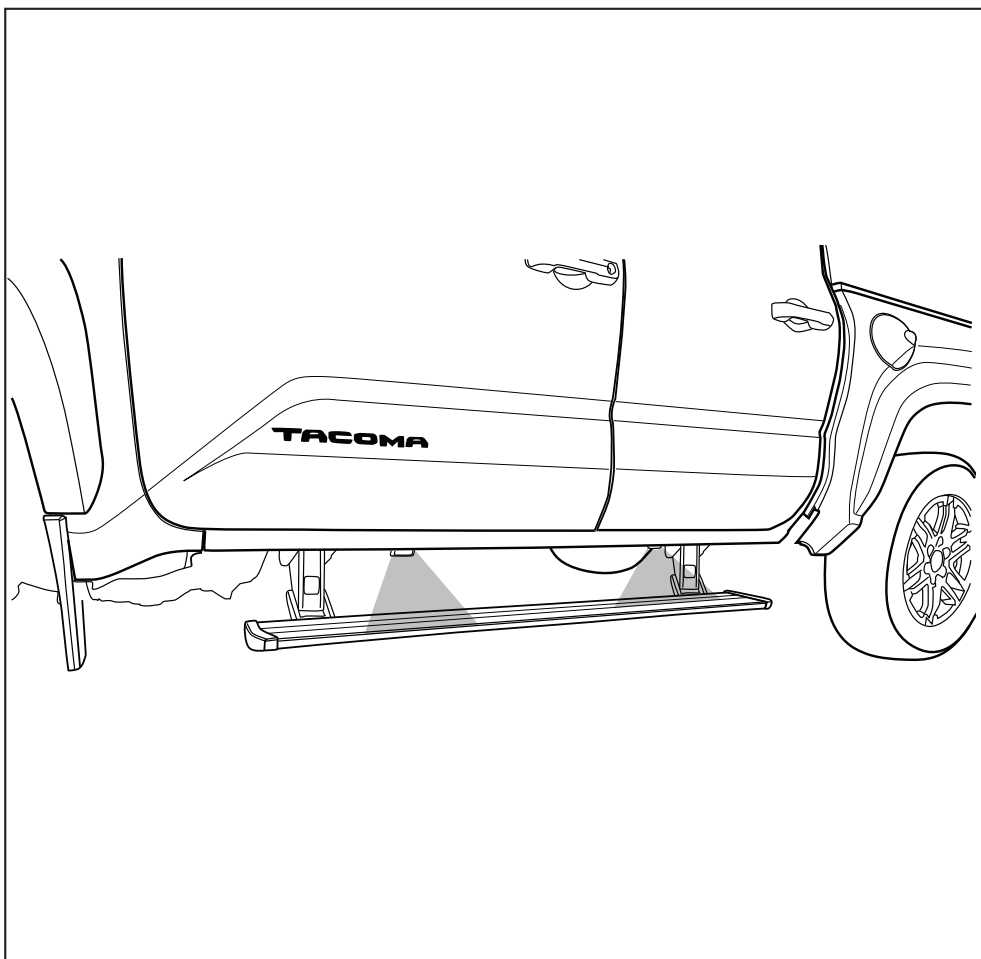

INSTALLATION TIME

3-5 Hours

Professional installation recommended

SKILL LEVEL



4= Experienced

WARRANTY

5-Year Limited Warranty

TOOLS REQUIRED

- Safety glasses
- Measuring tape
- 13 mm socket
- 10 mm socket
- Ratchet wrench and extension
- 12 mm end wrench
- Wire stripper / cutter
- 3/16" hex key wrench (allen wrench)
- 9/32 Drill Bit
- Drill
- Electrical tape
- T-20 Torx driver
- Heat Gun
- Wire Cutters/Crimpers

REALTRUCK TECH SUPPORT 1-888-983-2204 (Press 2) Monday - Friday, 8:00 AM - 5:00 PM EST

Designed and manufactured by RealTruck AMP Research® • Made in Mexico
Patent Protected. Please see our product site for applicable patents. www.realtruck.com/b/amp-research/
© RealTruck Group, Inc., 2025 • Five-year limited warranty. • Professional installation is recommended.

INSTALLATION GUIDE

Attaching motor to Linkage assembly

The motors must be attached to the Linkage assemblies before mounting to vehicle.

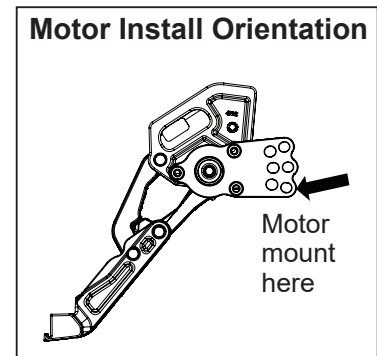
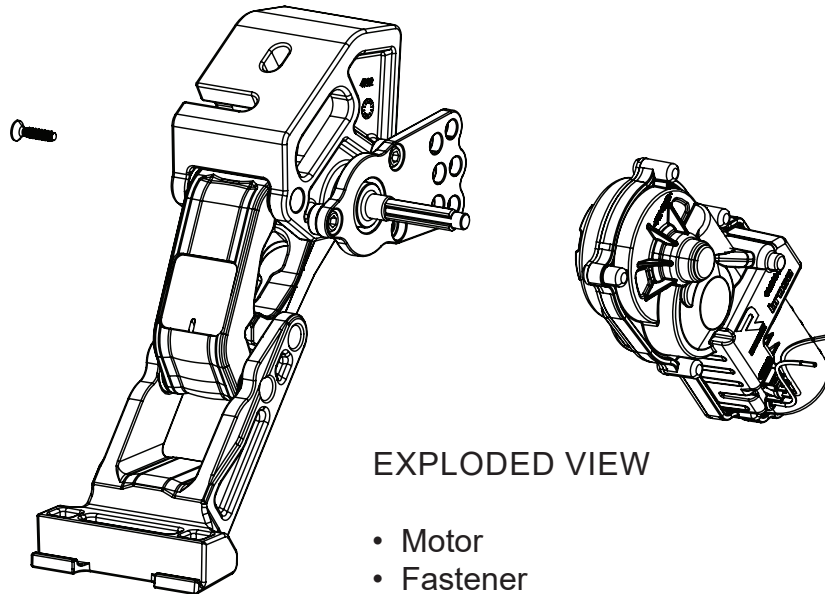

CAUTION: HANDLE WITH CARE.

To ensure our customers receive all components with full integrity, we pack the motors separate from their Linkage assemblies. This requires that the installer position and fasten the motor before continuing with the install. Please follow the instructions below and handle the assembly carefully.

CAUTION: Dropping the assembly or any excessive impact MAY cause damage to the motor.

Instructions:

1. Slide motor on to drive shaft.
2. Rotate motor by hand while on the shaft to position it to the mounting plate (orientation as shown above).
3. Fasten motor to the motor mounting plate using supplied PT Screw with T-20 Torx driver. Tighten screw to 60 in-lbs (6.8 N·m). **Do not over torque.**

Note:

The motor and shaft have only three possible positions. Depending on the current position of the motor, motor/shaft and the orientation of the motor plate, it may be necessary to power it in order to align it correctly with the linkage and shaft during assembly so that the motor can be mounted to the mounting plate.

To do this:

1. Power up the motor.
2. Open the door to allow the motor to spin and reposition.
3. Once the motor times out, remove the fuse.
4. Assemble the motor onto the shaft.
5. Fasten motor to mounting plate.

This process may need to be repeated to achieve the correct alignment.

PARTS LIST AND HARDWARE IDENTIFICATION

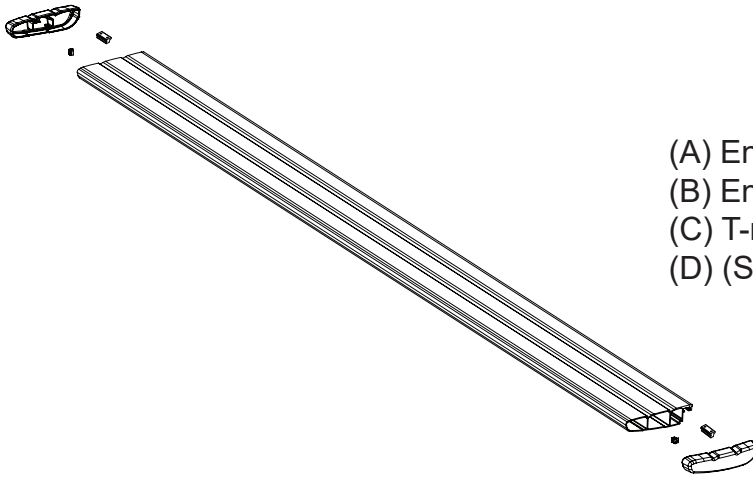

- (A) End cap left (x1)
- (B) End cap right (x1)
- (C) T-nut insert (x2)
- (D) (S) Style clips (x2)

1 x2

Running board assembly

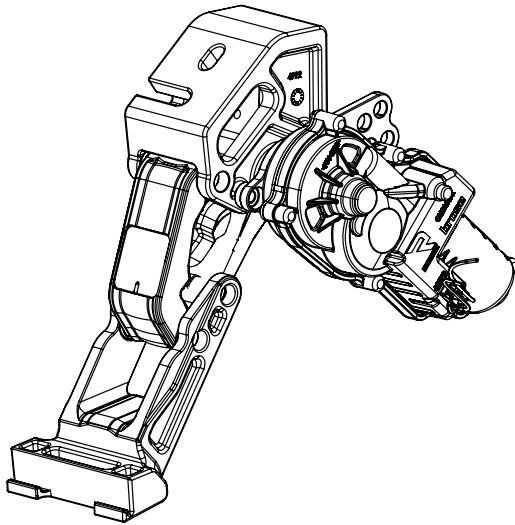

2 x2

Motor Linkage assembly
Passenger

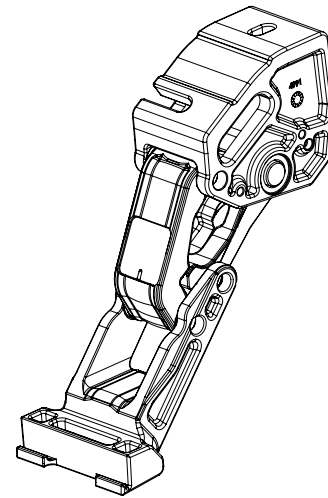

3 x2

Idler linkage assembly

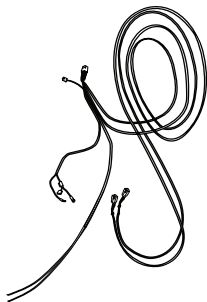

4

Wire harness

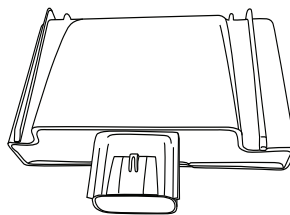

5

Controller SSA

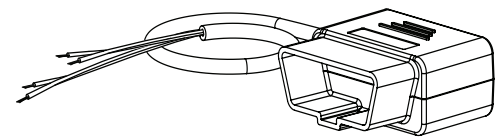

6

OBD II Plug

PARTS LIST AND HARDWARE IDENTIFICATION

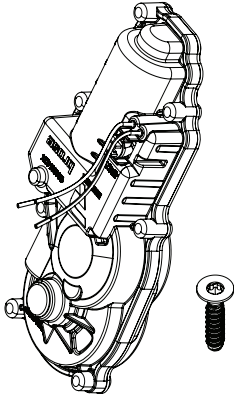

7 x2
Motor Assembly kit

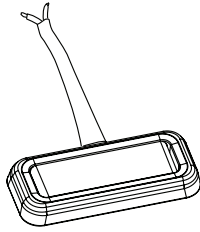

8 x4
LED Lamp

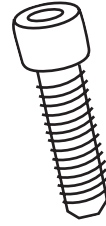

9 x8
Socket Cap Screw

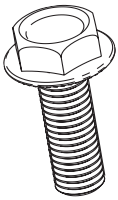

10 x 8
Hex Flange Bolt

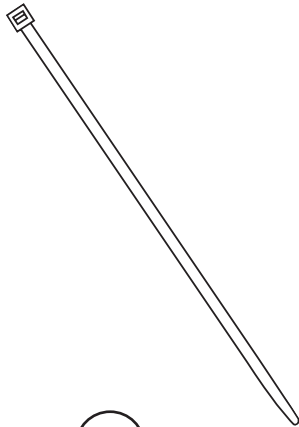

11 x2
Cable tie (11")

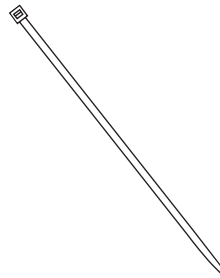

12 x20
Cable tie (7")

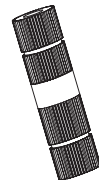

13
Posi-Lock™
(Grey)

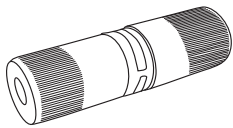

14 x4
Posi-Tite®

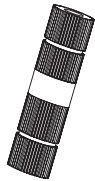

15 x2
Posi-Tap™
(Red/Black)

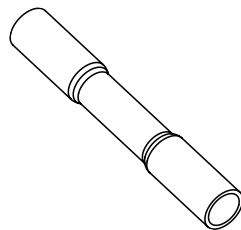

16 x8
Butt Connector



17 x5
Grommet

REALTRUCK AMP RESEARCH POWERSTEP – TOYOTA TACOMA

Locate Front Idler Linkage location. If plastic plugs or crews are present, remove to expose threads.

Pre thread supplied M10 Flange Bolt (10) and hook linkage over bolt as shown. Once linkage is in position thread in rear linkage mounting bolt (10). Snug up bolts but do not torque.

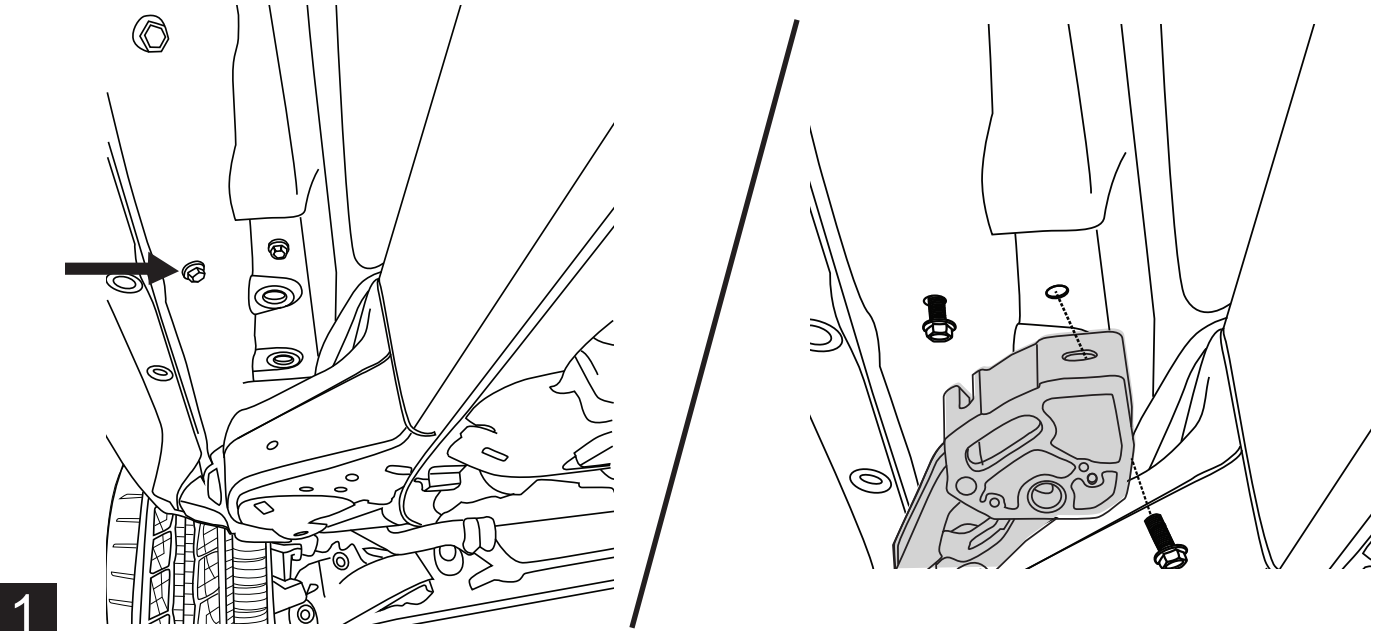

Locate rear Drive Linkage location. If plastic plugs or bolts are present, remove to expose threads.

Pre-thread supplied M10 Flange Bolt (10) and hook linkage over bolt as shown. Once linkage is in position thread in rear linkage mounting bolt. Snug up bolts but do not torque.

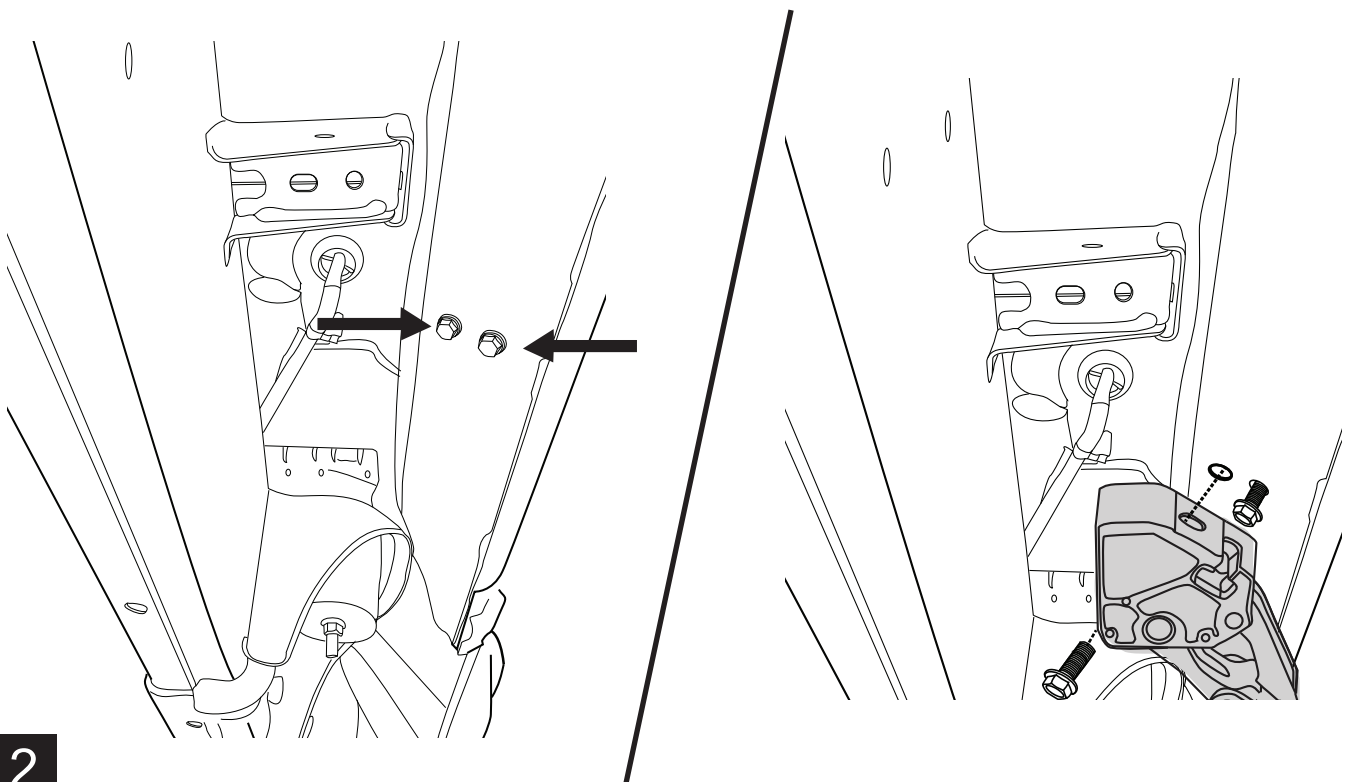

Install Running Board (1) to linkages.

Line up front edge of the running board to the front edge of the door.

In order to prevent binding follow the steps below.

Note: Hand cycle Boards between each step.

1. Tighten socket cap screws (12) with 3/16" Allen wrench (as shown on step 5). Torque to 10ft-lbs.
2. **Rear Linkage:** Tighten and torque Linkage upper mount bolt closest to pinch weld Torque to 30ft-lbs.
3. **Front Linkage:** Tighten and torque Linkage upper mount bolt closest to pinch weld. Torque to 30ft-lbs
4. **Rear Linkage:** Tighten and torque Linkage upper mount bolt closest to floor of cab. Torque to 30ft-lbs.
5. **Front Linkage:** Tighten and torque Linkage upper mount bolt closest to frame of truck. Torque to 30ft-lbs.
6. **Hand cycle boards to ensure no bind is present.**

Attach board to linkage tighten socket cap screws with 3/16" Allen wrench. Torque to 10ft-lbs.

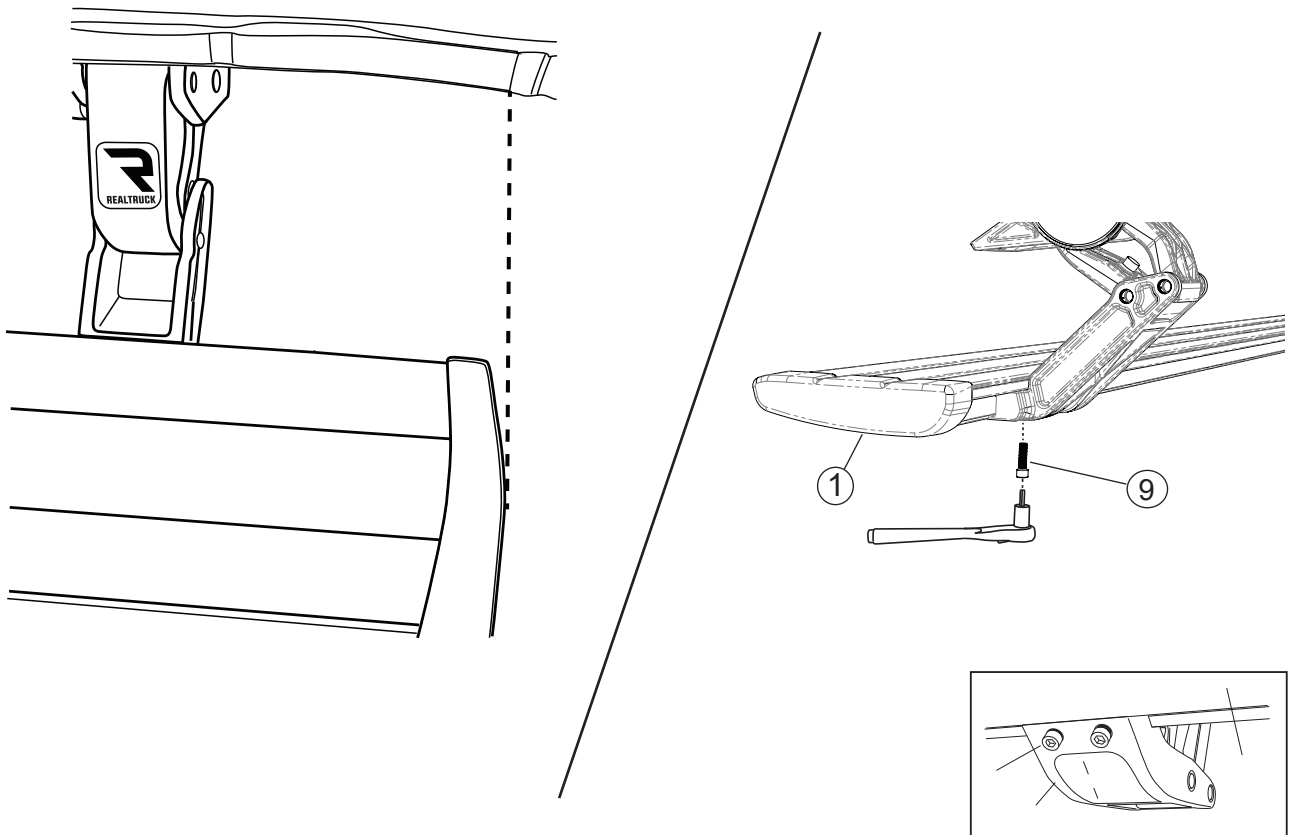

Remove power fuse.

Connect wire harness (4) to controller (5) and secure locking clip.

Connect red power lead to positive battery terminal and black ground lead to grounding lug on fender apron.

Use supplied 11" zip ties (11) to attach controller to battery bracket.

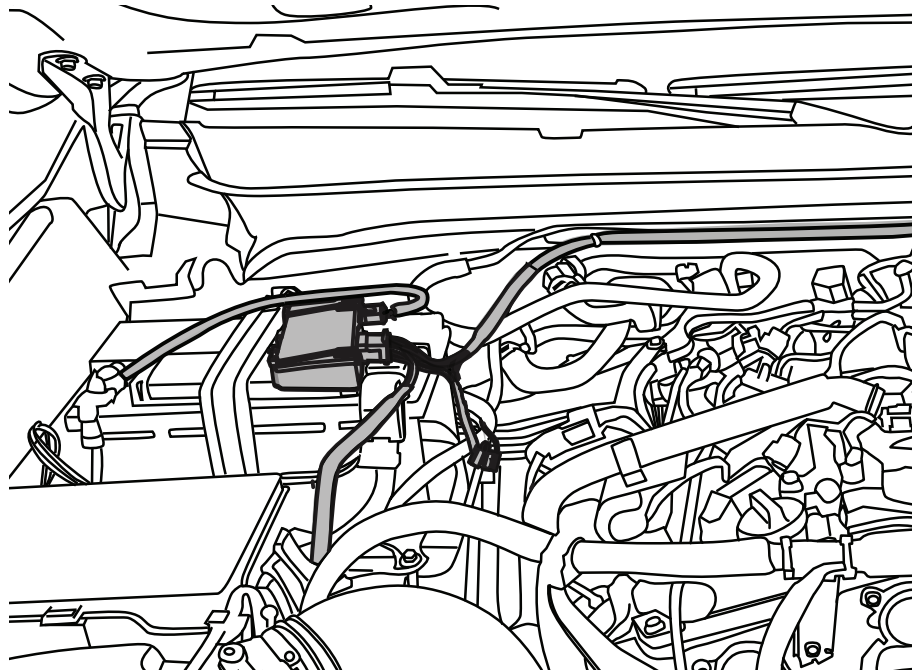

4

Route longest leg of wire harness across fire wall to driver side and under vehicle outside of frame rail. Route shorter leg of wire harness down passenger side fender well and under vehicle outside of frame rail. Use supplied 7" zip ties (12) where needed to secure harness.

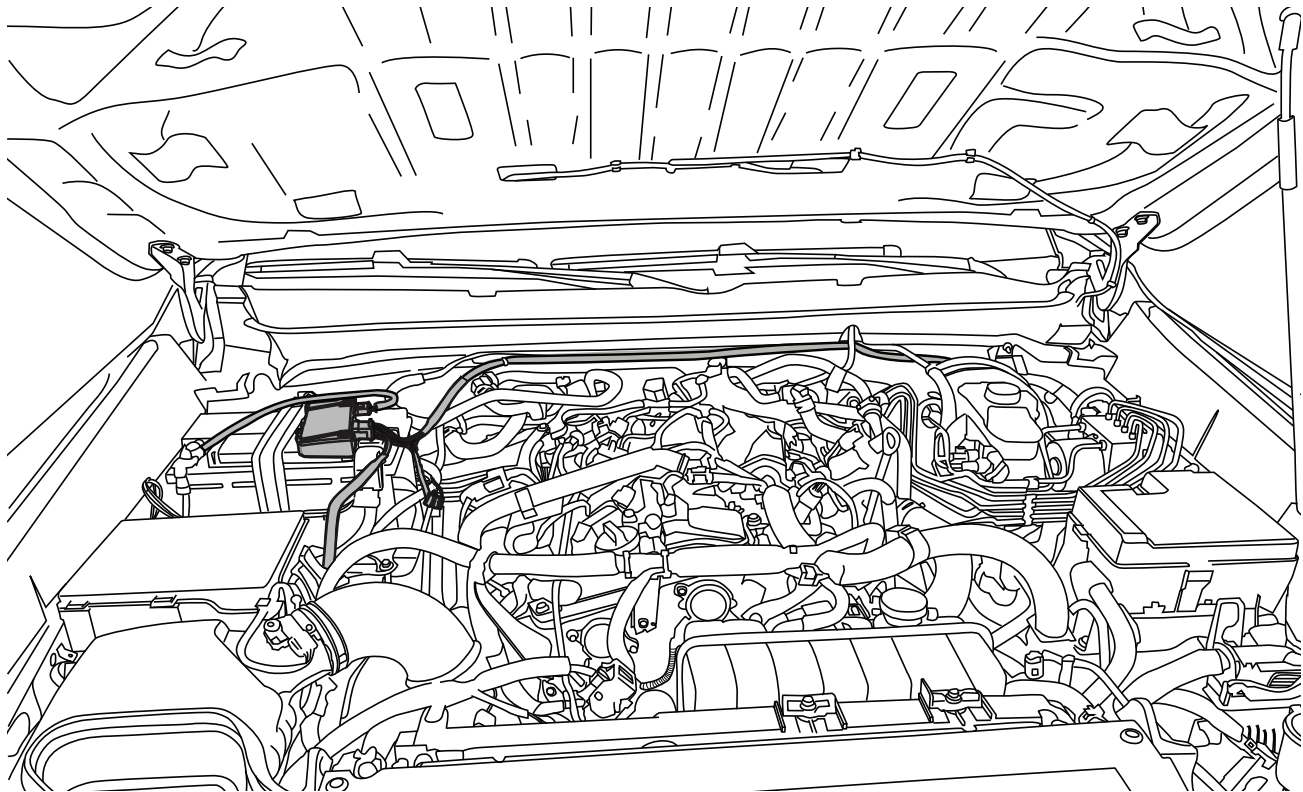

5

Remove driver front sill plate and kick panel. Pull up carpet. Locate rubber grommets under carpet in floorboards.

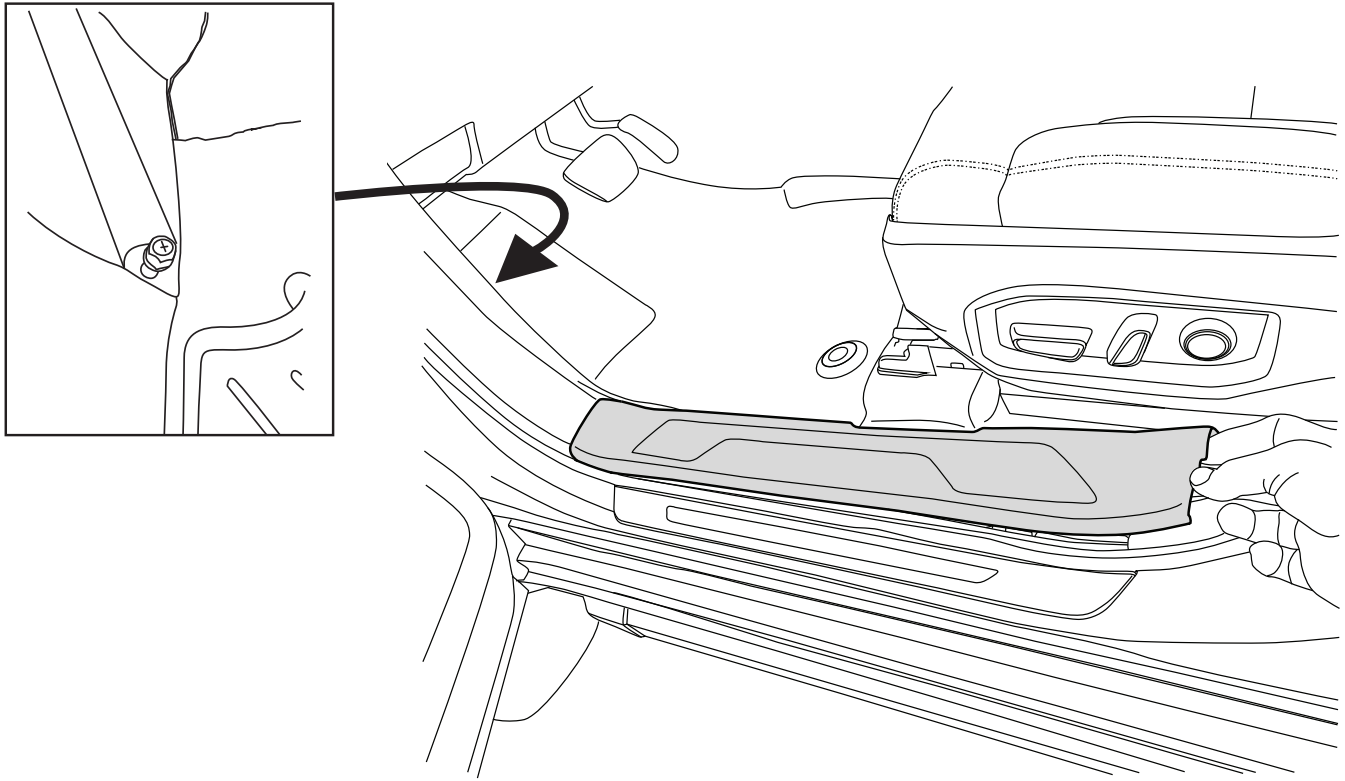

6

Cut a slit in the rubber grommet and pass the trigger wires up through grommet under carpet on the driver side.

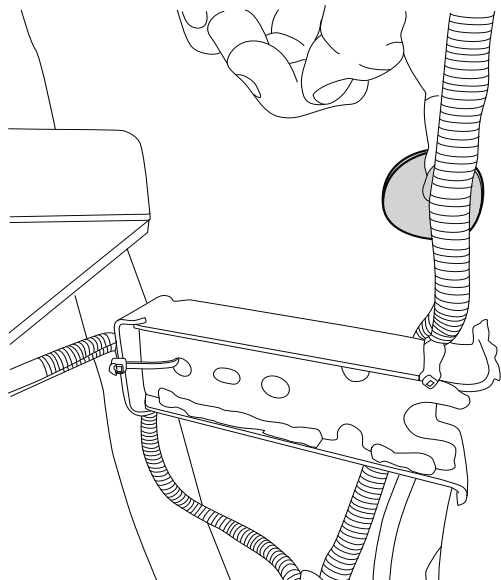

Posi-Tap™ instructions

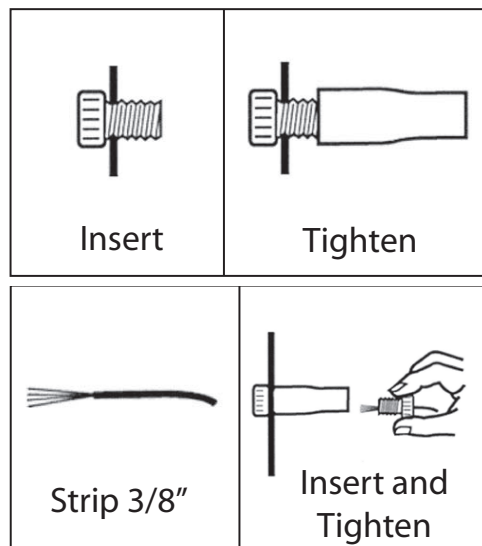

7

8

REALTRUCK AMP RESEARCH POWERSTEP – TOYOTA TACOMA

Locate white plug in driver kick panel area. Disconnect battery to avoid a Check Engine Light. Once battery is disconnected unplug plug to gain access. Locate the white and blue wire as shown in the plug. Using supplied posi-taps™ (15) connect the blue wire on the DSM to the white wire on the factory plug.

Next, connect the white wire, pin # 9, on the DSM module to the light blue wire, pin # 20, on the factory plug. Reconnect white factory plug.

Reinstall sill plate removed from step 6.

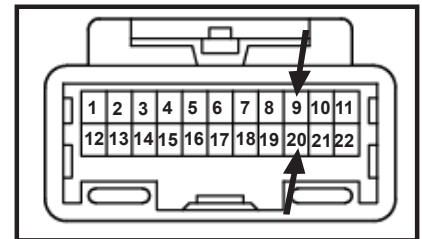
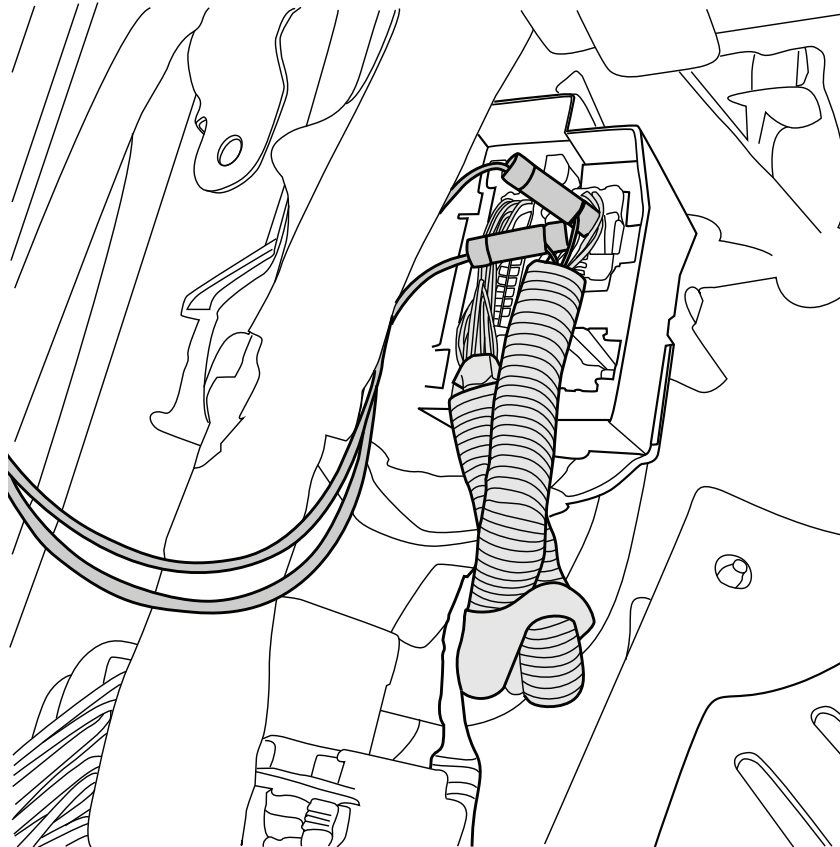
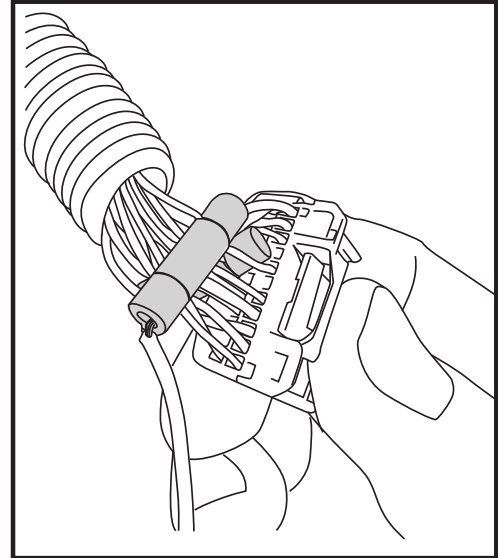
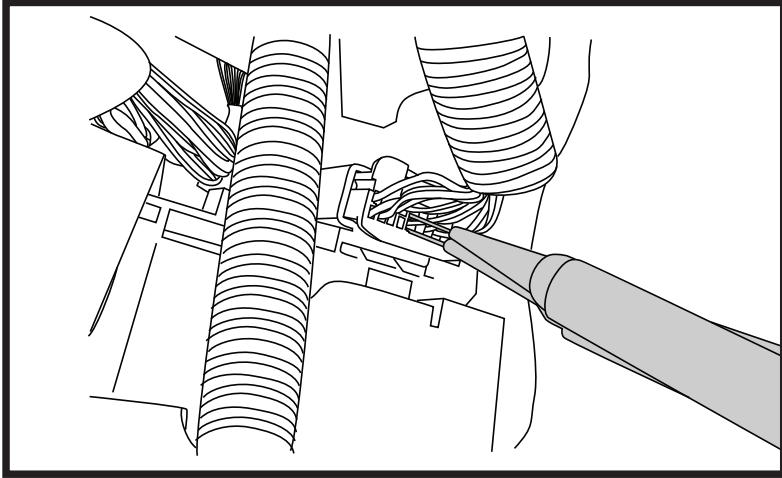

NOTE: Please see step 19 for DSM Activation procedure to ensure proper operation of powersteps!

OBD II install: Use Supplied Posi-lock™ (13) connector to attach the Plug and Play Module to the Harness. Attach matching colors on the harness to the wires on the module. Plug in module (8) to OBD II port on the vehicle. Secure harness with supplied tie wraps (12). *Note: If the OBD II pass thru harness (76405-01A) was purchased see install sheet supplied in packaging. The pass through harness allows for an open port for other accessories. See below for images with brief descriptions.*

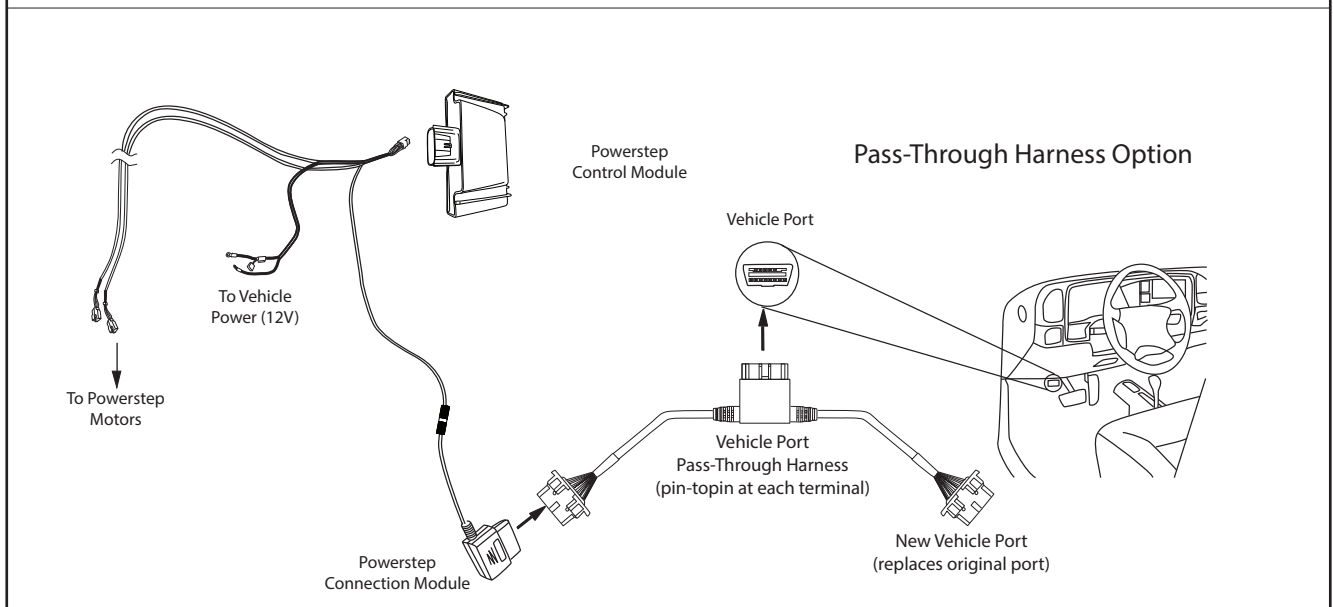
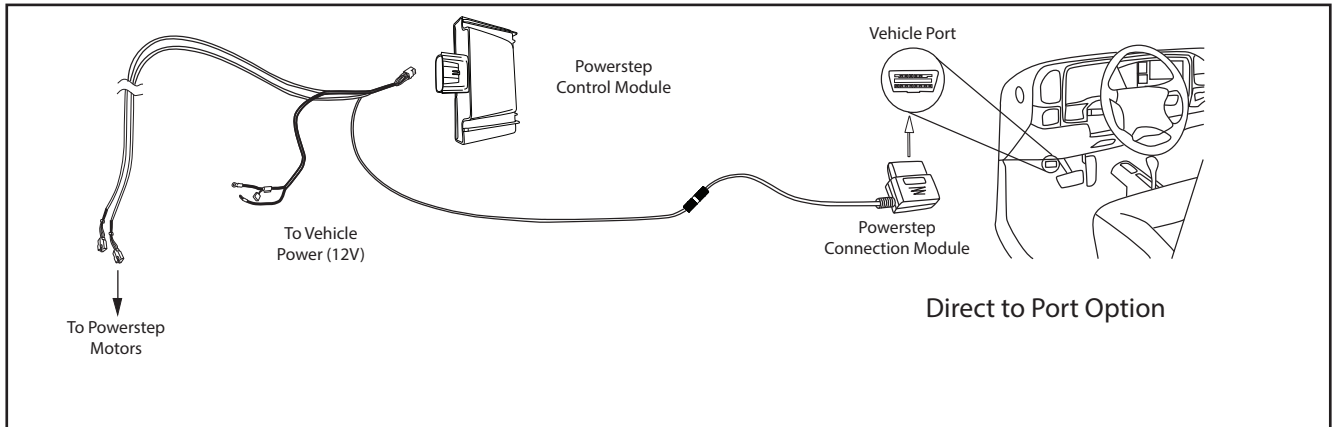

Plug in module to OBD port on the vehicle.

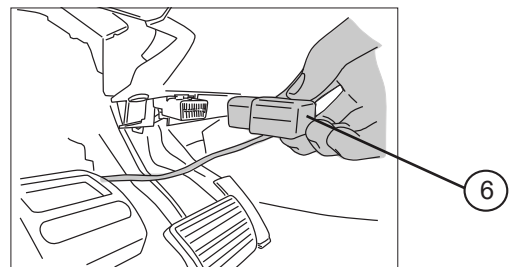
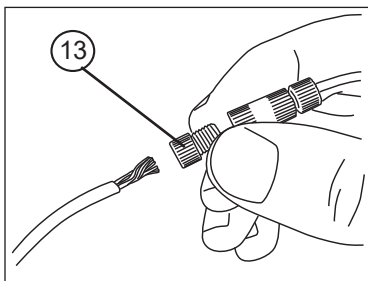

Connect wire harness to motor. Use method B. for passenger and driver side.

A. Motor spinning the shaft clockwise direction:

- 1) First, install one Posi-Tite® (14) onto black wire from the motor. See image on right.
- 2) Install second Posi-Tite® onto red with purple stripe wire from motor. See image on right.

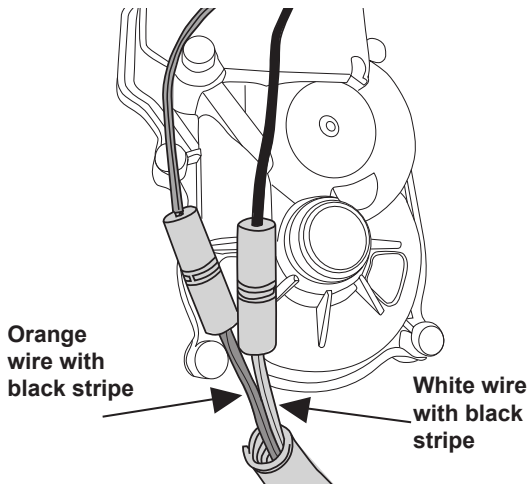

- 3) Next, connect the white wire with black stripe from the wire harness to the other end of the Posi-Tite® that is connected to the all black wire from first step above.
- 4) Connect the Posi-Tite® the red with purple stripe wire from the motor with the orange with black stripe wire from the harness.

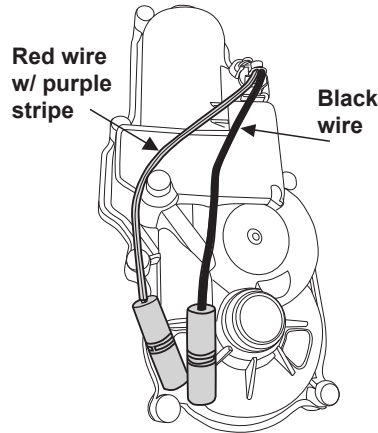

Posi-Tite® Instructions

1. Strip 3/8"
2. Push
3. Tighten

B. Motor spinning the shaft counter clockwise direction:

- 1) First, install one Posi-Tite® (14) onto black wire from the motor. See image on right.
- 2) Install second Posi-Tite® onto Red wire with purple stripe from motor. See image on right.

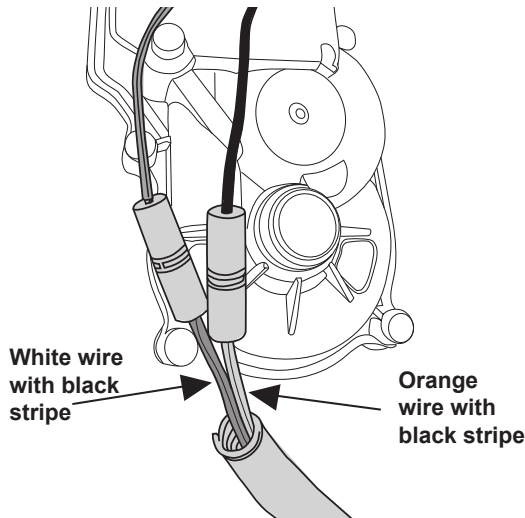

- 3) Next, connect the orange wire with black stripe from the wire harness to the other end of the Posi-Tite® that is connected to the all black wire from first step above.
- 4) Connect the Posi-Tite® the red wire with purple stripe from the motor with the white with black stripe wire from the harness.

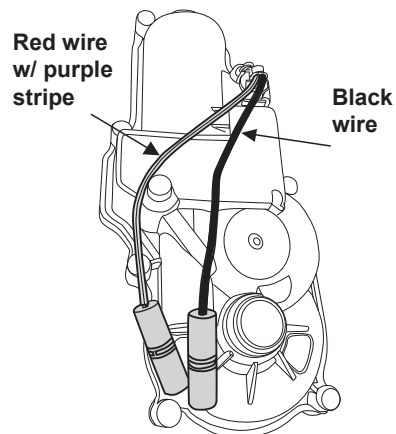

Posi-Tite® Instructions

1. Strip 3/8"
2. Push
3. Tighten

NOTE: If motors are moving in opposite direction after wiring; switch wiring configuration on either passenger or driver side to correct this issue.

REALTRUCK AMP RESEARCH POWERSTEP – TOYOTA TACOMA

On each side of the vehicle measure from the front edge of door line on the pinch weld to the specified lengths below. Measure at 20" for front LED Light and 57" for rear LED Light.

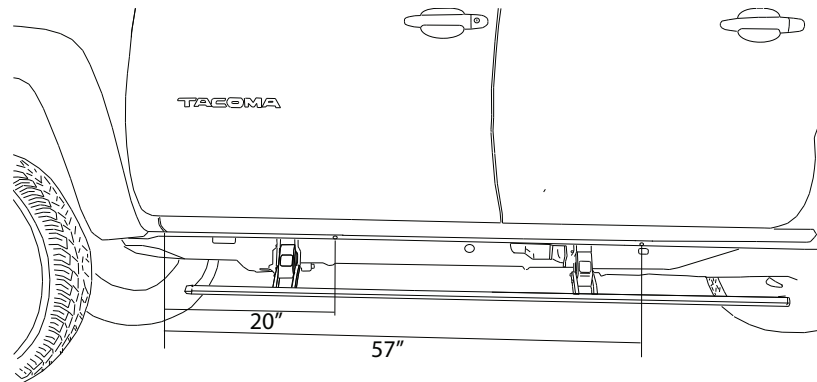

12

Drill a pilot hole followed by a 9/32" hole through the pinch weld at marked locations. Deburr all holes.

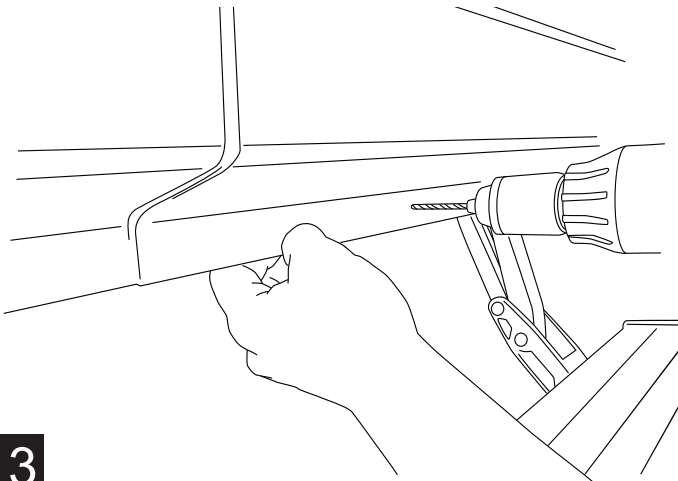

13

Insert grommet into drilled holes. Insert lamp wires through the grommets. (Silicon lube will help wires slip through grommets.)

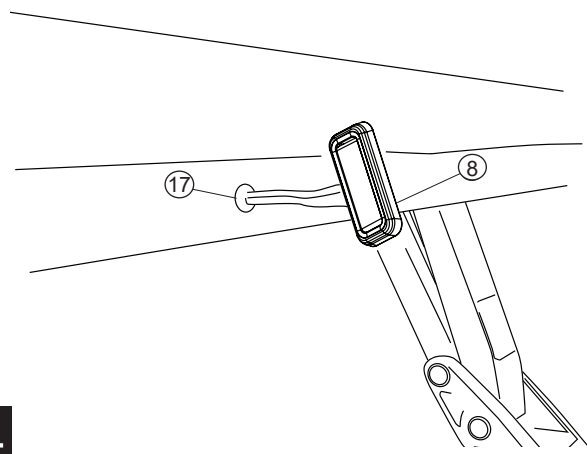

14

Affix lamp to rocker panel surface. Make sure lamp is affixed to a flat, clean surface.

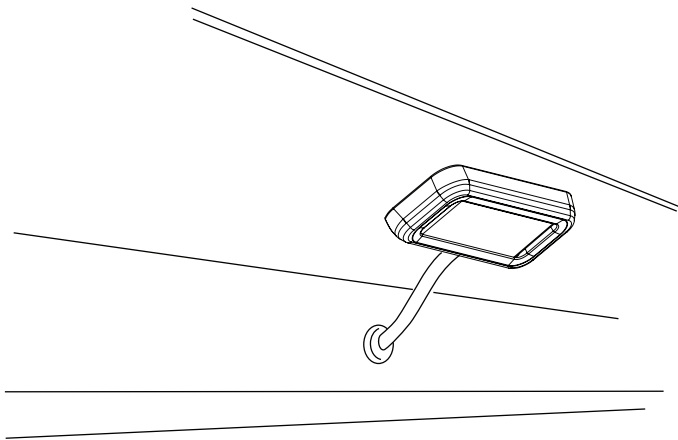

15

Using supplied butt connectors, connect the lamp wires. Red to Red, Black to Black. Once Crimped use heat gun to shrink tube.

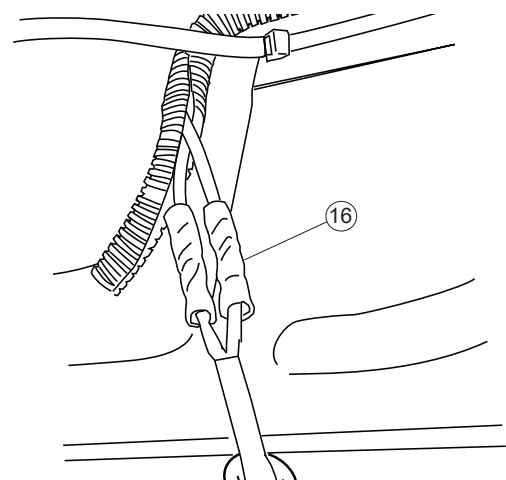

16

Close and wrap with conduit and electrical tape. Secure all loose wires with cable ties, with lamp wires pulled upward to avoid any wire snagging.

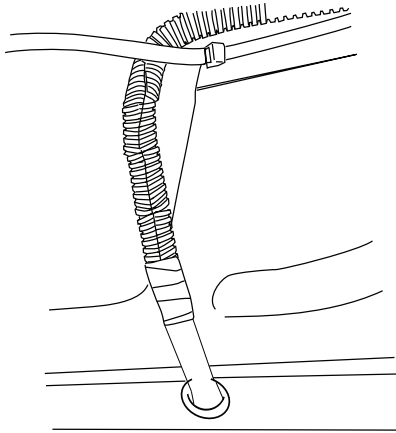

17

Reinstall fuse.

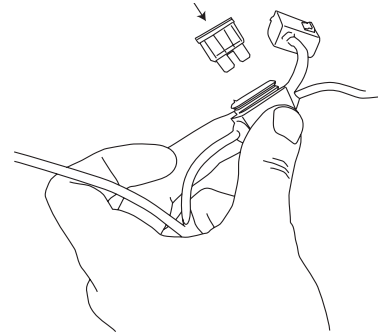

18

Check that all doors activate the Power Step and the LED Lights work when doors open and close. Reinstall any remaining trim panels.

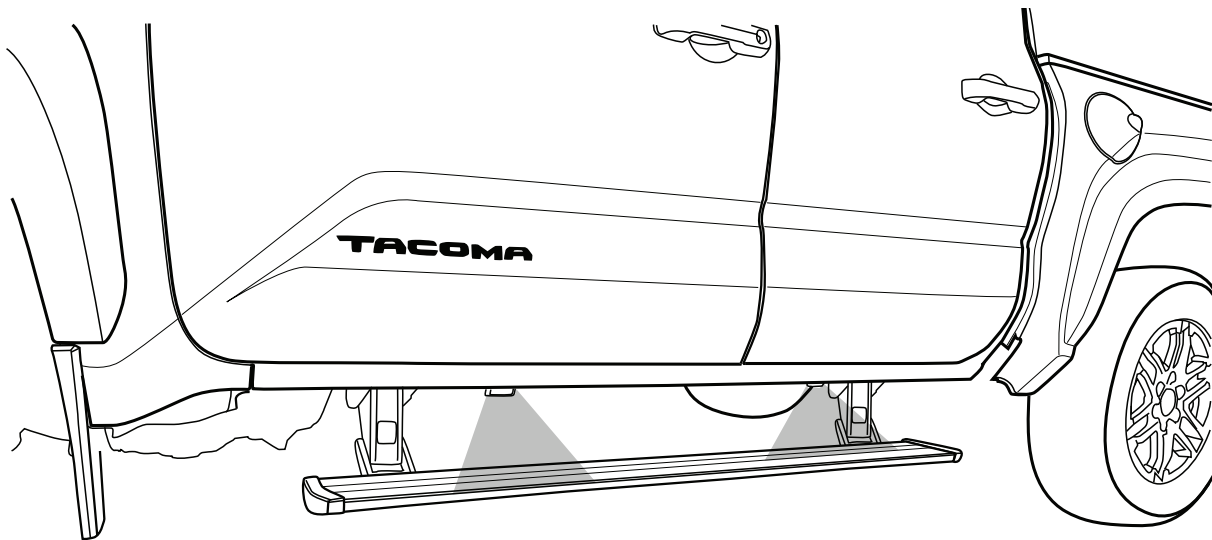

FINAL SYSTEM CHECK

Check that all doors activate the PowerStep and the LED lights work when doors open and close.

NORMAL OPERATION: When the doors open, PowerStep automatically deploys from under the vehicle. When the doors are closed, PowerStep will automatically return to the stowed/retracted position. **Note that there is a 2-second delay before the PowerStep returns to the stowed/retracted position.**

CORRECT OPERATION OF LIGHTS: All four lamps will illuminate upon opening any door of vehicle. Lamps will stay on until restowing of both Power Steps or until 5 minutes has expired with the doors open. When the lights timeout after 5 minutes, they can be reilluminated by closing and opening any door of vehicle.

19



AMERICAN DESIGNED & ENGINEERED

Thank you for your recent RealTruck purchase.

REGISTER YOUR PRODUCT TODAY FOR FASTER SERVICE & PRODUCT UPDATES

Please visit:

<https://realtruck.com/warranty-registration/>
or scan the QR Code



Product Registration Benefits:

- Ensure we have your purchase receipt and product info in our system which is required for warranty.
- Faster and easier access to customer service and tech support in the unlikely event you need warranty or product support.
- Registration helps us keep you up to date on product information and offers.

To view other RealTruck products that may be offered for your vehicle.

Please visit: www.realtruck.com

Rev 05.30.24

Congratulations on your purchase of the genuine RealTruck / AMP Research PowerStep! Here's what you should know...

POWER-DEPLOYABLE RUNNING BOARDS OPERATION: RealTruck / AMP Research PowerStep running boards automatically move when the doors are opened to assist entering and exiting the vehicle.

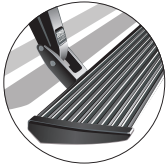

Automatic power deploy:

The running boards will extend down and out when the doors are opened.

Automatic power stow:

The running boards will return to the stowed position when the doors are closed. There will be a 2-second delay before the running boards move to the stowed position.

Automatic stop:

If an object is in the way of the moving running board, the running board will automatically stop. To reset, clear any obstruction, then simply open and close the door to resume normal operation.



Manually set in the deployed (OUT) position for access to the roof:

The running boards can be manually set in the deployed position by firmly holding the step down with your foot while at the same time closing the door. To resume normal operation, open and close the door.

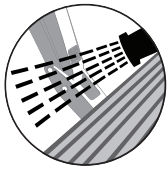

Maintenance: In adverse conditions, debris such as mud, dirt, and salt may become trapped in the running board mechanism, possibly leading to unwanted noise. If this occurs, manually set the running boards to the deployed position and flush the front and rear hinge arms with a high-pressure car wash wand.

Avoid spraying the motors directly. After washing, apply silicone spray lubricant to the hinge pivot pins. Do not apply silicone, wax or protectants like Armor All® to the running board stepping surface.

Caution! Keep hands away when the running board is in motion.

5-YEAR LIMITED WARRANTY

RealTruck / AMP RESEARCH warrants this product to be free from defects in material and workmanship for FIVE (5) YEARS FROM DATE OF PURCHASE, provided there has been normal use and proper maintenance. This warranty applies to the original purchaser only. All remedies under this warranty are limited to the repair replacement of the product itself, or the repair or replacement of any component part thereof, found by the factory to be defective within the time period specified. The decision to repair or replace is wholly within the discretion of the manufacturer.

This warranty specifically excludes labor. If you have a warranty claim, first you must call our factory at the number below for instructions. You must retain proof of purchase and submit a copy with any items returned for warranty work. Upon completion of warranty work, if any, we will return the repaired or replaced item or items to you freight prepaid. Damage to our products caused by accidents, fire, vandalism, negligence, misinstallation, misuse, acts by nature or by defective parts not manufactured by us, is not covered under this warranty.

ANY IMPLIED WARRANTIES OF MERCHANTABILITY AND/OR FITNESS FOR A PARTICULAR PURPOSE CREATED HEREBY ARE LIMITED IN DURATION TO THE SAME DURATION AND SCOPE AS THE EXPRESS WRITTEN WARRANTY. OUR COMPANY SHALL NOT BE LIABLE FOR ANY INCIDENTAL OR CONSEQUENTIAL DAMAGE.

Some states do not allow limitations on how long an implied warranty lasts, or the exclusion or limitation of incidental or consequential damages, so the above limitations or exclusions may not apply to you. This warranty gives you specific legal rights, and you may also have other rights that vary from state to state.

FOR WARRANTY ISSUES WITH THIS PRODUCT PLEASE CALL REALTRUCK TECH SUPPORT 1-888-983-2204

WARNING

Be sure to read and precisely follow the provided instructions when installing this product. Failure to do so could place the vehicle occupants in a potentially dangerous situation. After installing or reinstalling, re-check to insure that the product is properly installed.



The material that your product is made from can be recycled. Please also consider recycling the packaging that your product came in.

