

APPLICATION	LENGTH	MODEL YR	PART #
Ford Ranger - Super Crew	72"	2019 - 2023	76140-01A
Ford Ranger - Super Cab	65"	2019 - 2023	76140-01A
Ford Bronco - 2 Door	55"	2021 - 2025	76140-01A
Ford Bronco - 4 Door	72"	2021 - 2025	76140-01A

(Excludes RAPTOR models)

INSTALLATION GUIDE

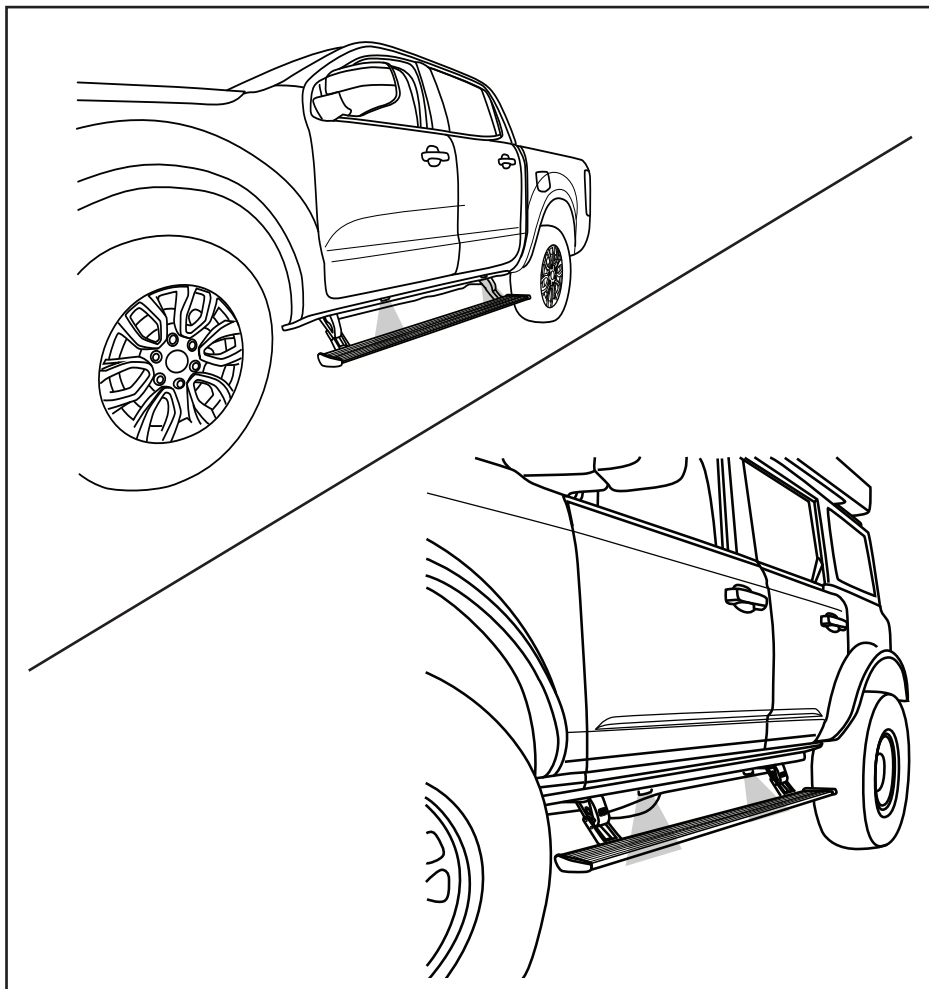

INSTALLATION TIME

3-5 Hours

Professional installation recommended

SKILL LEVEL



4= Experienced

TOOLS REQUIRED

- Safety goggles
- Measuring tape
- 10 mm socket
- 10 mm ratchet wrench
- 13 mm ratchet wrench
- 15 mm ratchet wrench
- Ratchet wrench and extension
- Pliers
- Wire crimpers
- Wire stripper / cutter
- 3/16" H ex key wrench (allen wrench)
- Electrical tape
- Weather proof caulking (silicone sealer)
- 1/8" Drill bit
- 9/32" Drill bit
- Drill
- Heat Gun
- 6" Extension
- T25 Torx-screw

WARRANTY

5-Year Limited Warranty

REALTRUCK TECH SUPPORT 1-888-983-2204 (Press 2) Monday - Friday, 8:00 AM - 5:00 PM EST

Designed and manufactured by RealTruck AMP Research® • Made in Mexico
 Patent Protected. Please see our product site for applicable patents. www.realtruck.com/b/amp-research/
 © RealTruck Group, Inc., 2025 • Five-year limited warranty. • Professional installation is recommended.

INSTALLATION GUIDE

Attaching motor to Linkage assembly

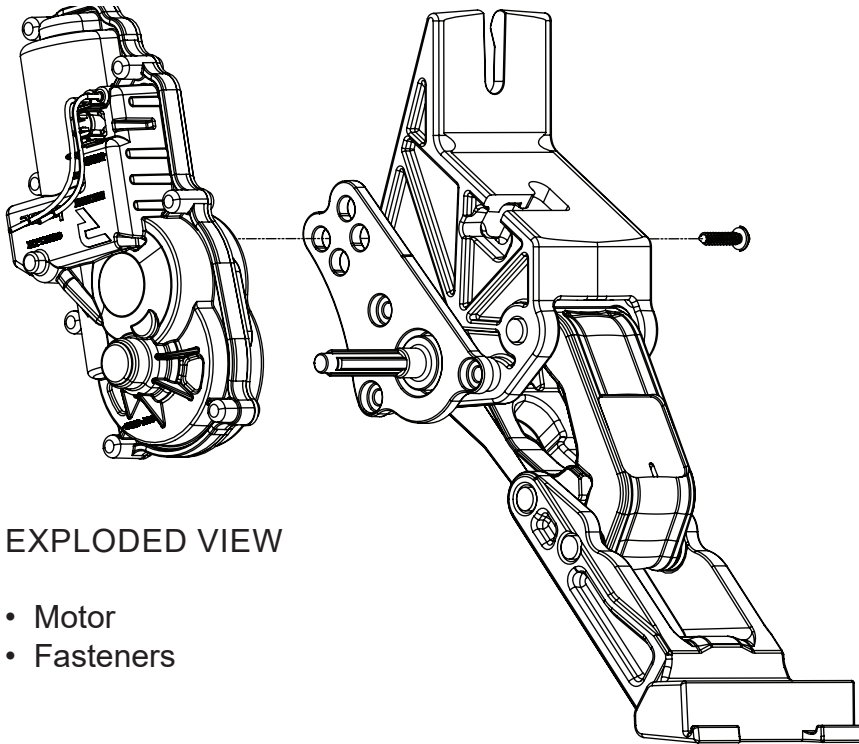

EXPLODED VIEW

- Motor
- Fasteners

Motor Install Orientation

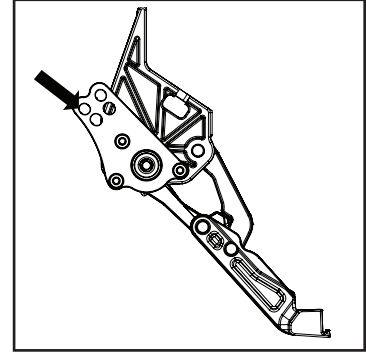

Attaching motor to linkage assembly.

CAUTION: Dropping the assembly or any excessive impact MAY cause damage to the motor, please handle with care.

Instructions:

1. Slide motor on to drive shaft.
2. Rotate motor by hand while on the shaft to position it to the mounting plate (orientation as shown above). **Note: make sure seat motor all the way before tightening.**
3. Fasten motor to the motor mounting plate using supplied PT Screw with T-25 Torx driver. Tighten screw to 60 in-lbs (6.8 N·m). **Do not over torque.**

Note:

The motor and shaft have only three possible positions. Depending on the current position of the motor, motor/shaft and the orientation of the motor plate, it may be necessary to power it in order to align it correctly with the linkage and shaft during assembly so that the motor can be mounted to the mounting plate.

To do this:

1. Power up the motor.
2. Open the door to allow the motor to spin and reposition.
3. Once the motor times out, remove the fuse.
4. Assemble the motor onto the shaft.
5. Fasten motor to mounting plate.

This process may need to be repeated to achieve the correct alignment.

Note: Some Applications require modification.

COMPONENT/PARTS IDENTIFICATION

Application	Cut Length
Ranger Crew Cab, Bronco 4 Door	72" (No Modification Required)
Extended Cab	65" (Trim 7")
Bronco 2 Door	55" (Trim 17")

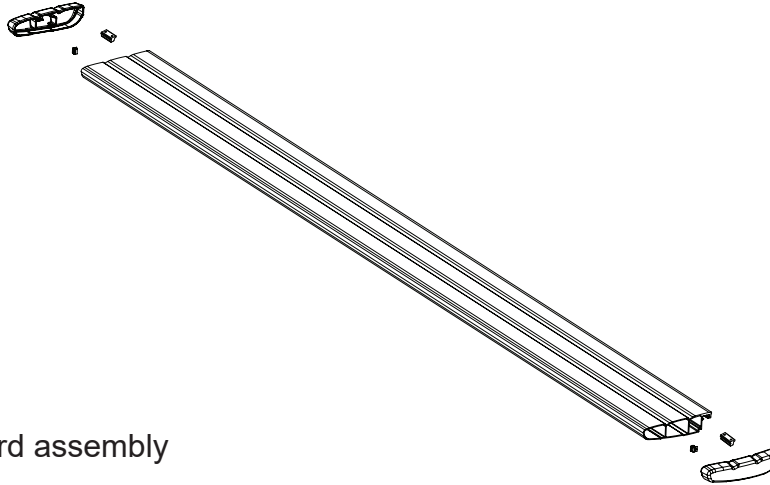

1 x2

Running Board assembly

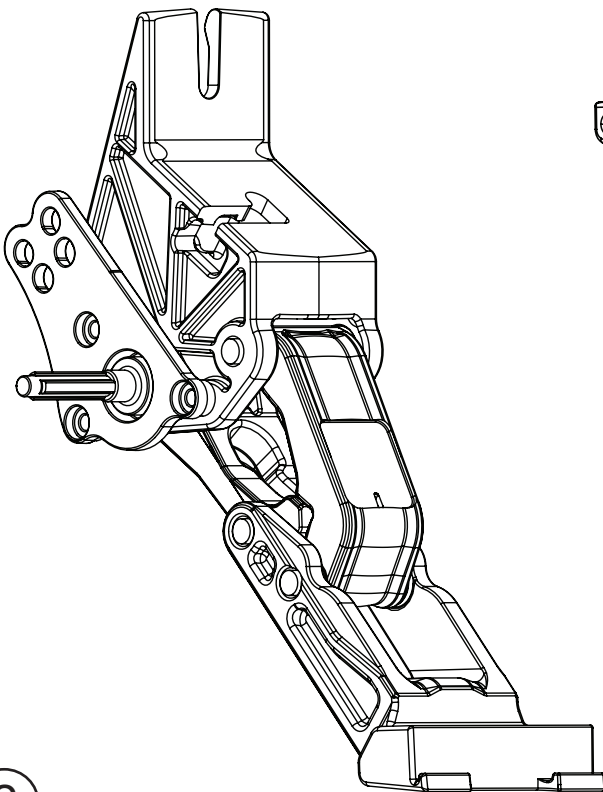

2 x2

Motor Linkage Assembly (Rear)

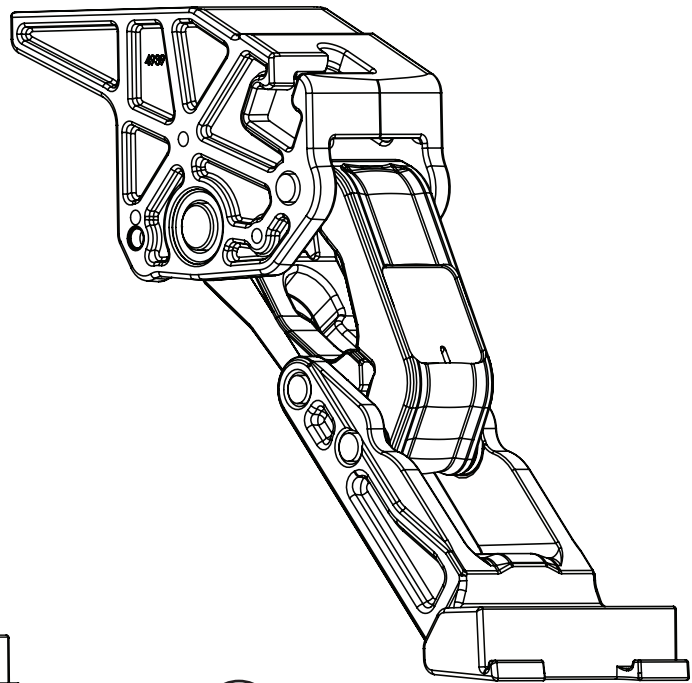

3 x2

Idler Linkage Assembly (Front)

PARTS LIST AND HARDWARE IDENTIFICATION

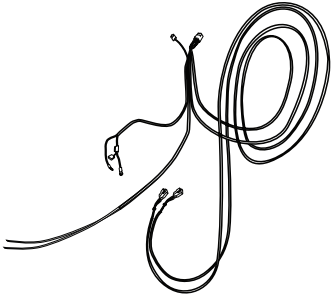

④
Wire Harness

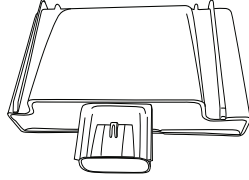

⑤
Controller SSA

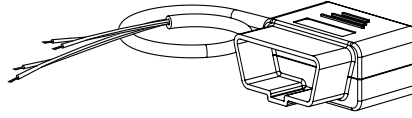

⑥
ODB II Plug

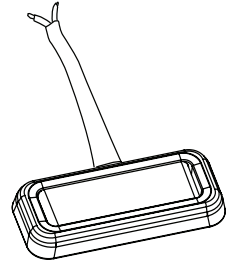

⑦ x4
LED Lamp

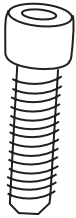

⑧ x8
Socket Cap Screw

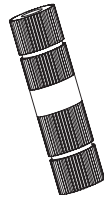

⑨
Posi-Lock™ (Grey)



⑩ x2
Posi-Tap™
(Red/Black)

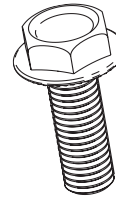

⑪ x8
Hex Flange Bolt

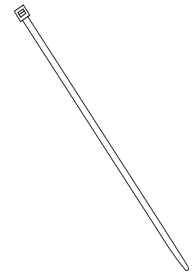

⑫ x20
Cable Tie 7"

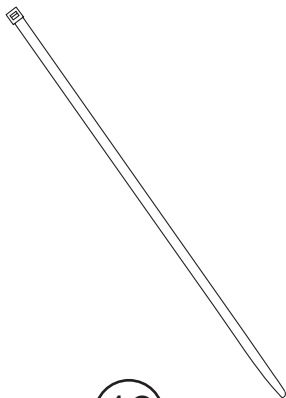

⑬ x2
Cable Tie 11"



⑭ x5
Grommet

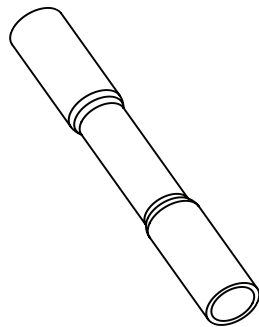

⑮ x8
Butt Connector

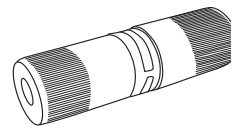

⑯ x4
Posi-Tite®

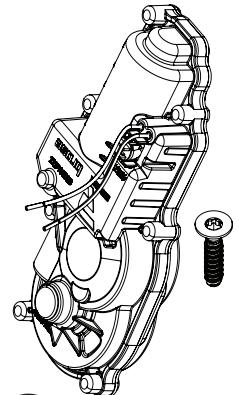

⑰ x2
Motor Assembly kit

Locate **Front Idler linkage** location. If plastic plugs are present remove plastic plugs to expose threads.

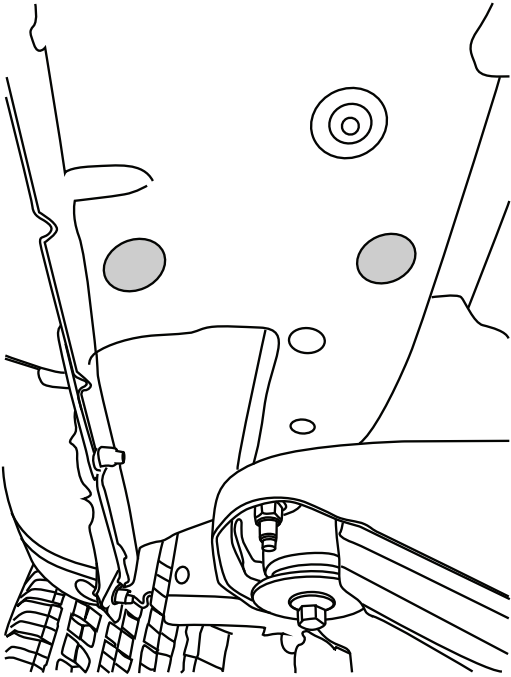

1

Pre thread supplied M10 flange bolt and hook linkage (3) over bolt as shown. Once linkage is in position thread in rear linkage mounting bolt (11). Snug up bolts but do not torque.

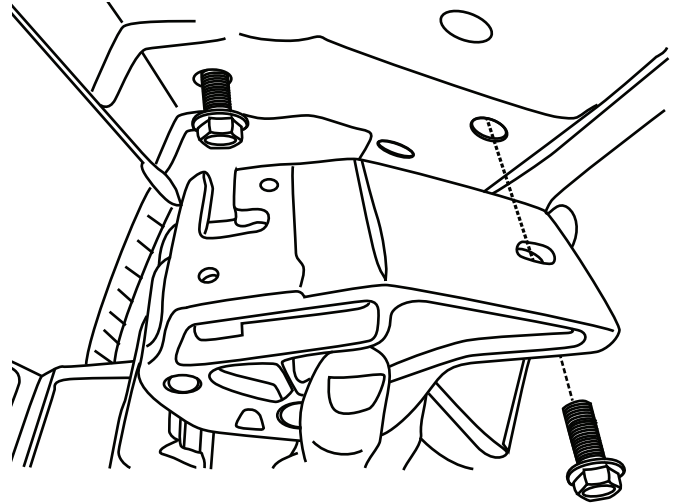

2

Locate **Rear Drive linkage** location. If plastic plugs are present remove plastic plugs to expose threads.

Pre thread supplied M10 flange bolt (11) and hook linkage (2) over bolt as shown. Once linkage (2) is in position thread in rear linkage mounting bolt. Snug up bolts but do not torque.

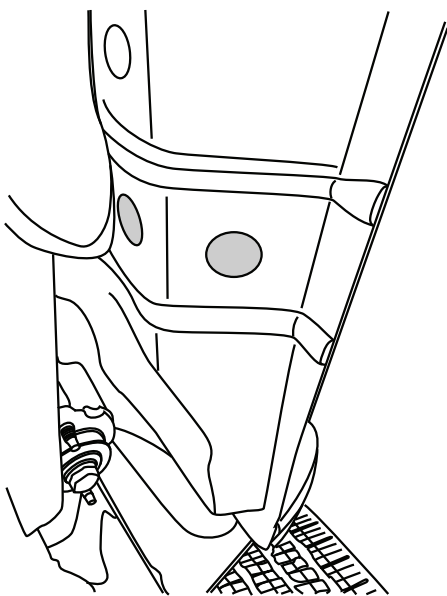

3

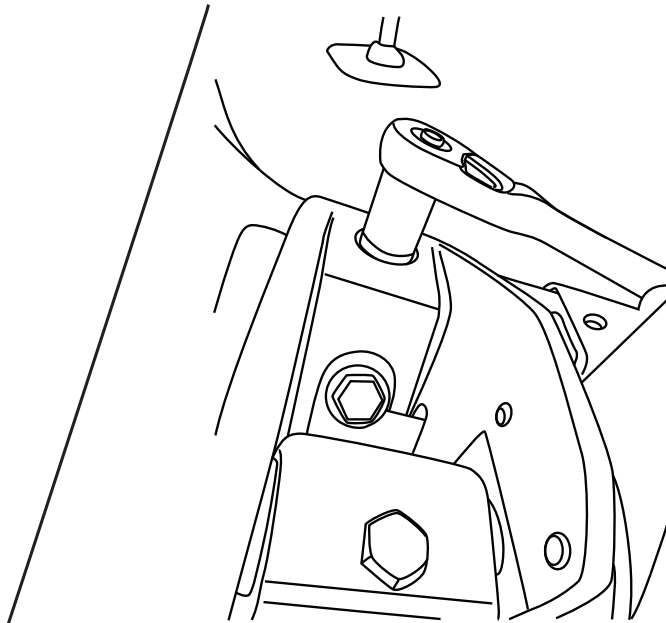

Install Running Board (1) to linkages.

Ranger: Measure approx. 4.5" from back of linkage to tip of board.

Bronco: Measure approx. 9.5" from back of linkage to tip of board.

In order to prevent binding follow the steps below.

Note: Hand cycle Boards between each step.

1. Tighten socket cap screws (9) with 3/16" Allen wrench (as shown on step 5). Torque to 10ft-lbs.
2. **Rear Linkage:** Tighten and torque Linkage upper mount bolt closest to pinch weld Torque to 30ft-lbs.
3. **Front Linkage:** Tighten and torque Linkage upper mount bolt closest to pinch weld. Torque to 30ft-lbs
4. **Rear Linkage:** Tighten and torque Linkage upper mount bolt closest to floor of cab. Torque to 30ft-lbs.
5. **Front Linkage:** Tighten and torque Linkage upper mount bolt closest to frame of truck. Torque to 30ft-lbs.
6. **Hand cycle boards to ensure no bind is present.**

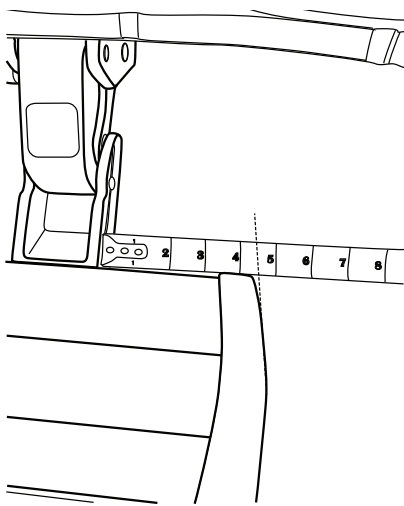

4

Ford Ranger

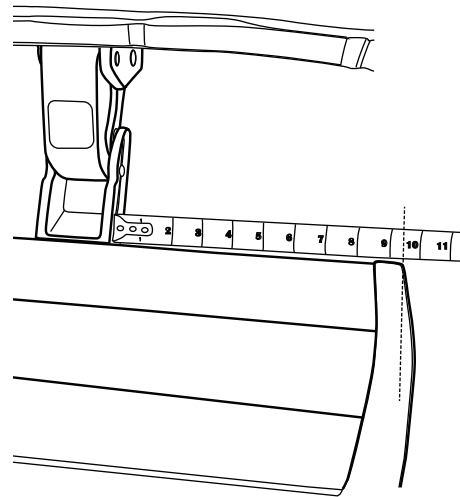

Ford Bronco

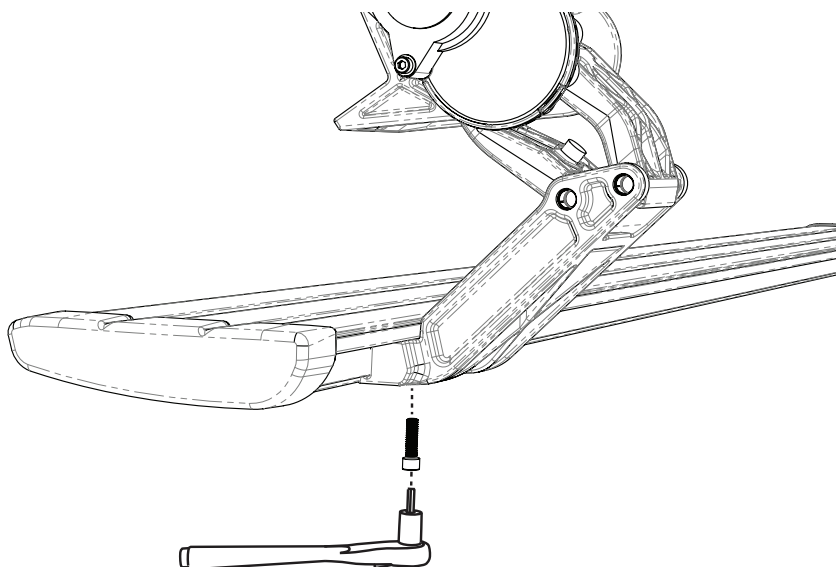

5

IMPORTANT NOTE!

**Ford Ranger follow steps 6 through 12.
Ford Bronco skip to step 13.**

Ford Ranger ONLY:

Remove Fuse from powerstep wire harness. Mount controller (5) using supplied zip ties (13) to harness in front of battery as shown. Connect positive leads from harness. Red to positive battery terminal and black to body ground.

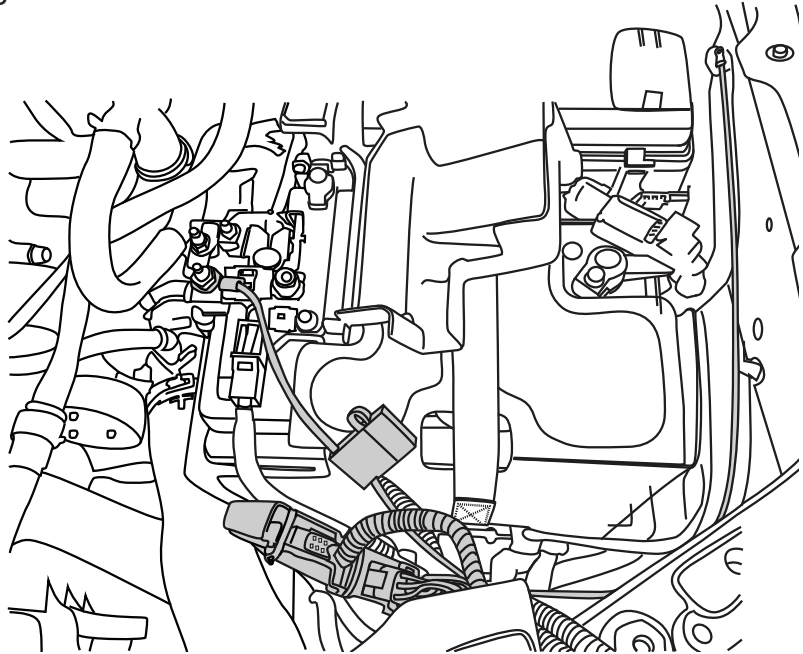
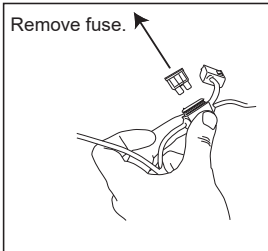

6

Route the two wire harness legs down over to each wheel well. Long leg will run across to passenger side, short leg will run down to driver side. Ensure loom is free from steering and exhaust components. Use zip ties (12) to secure harness.

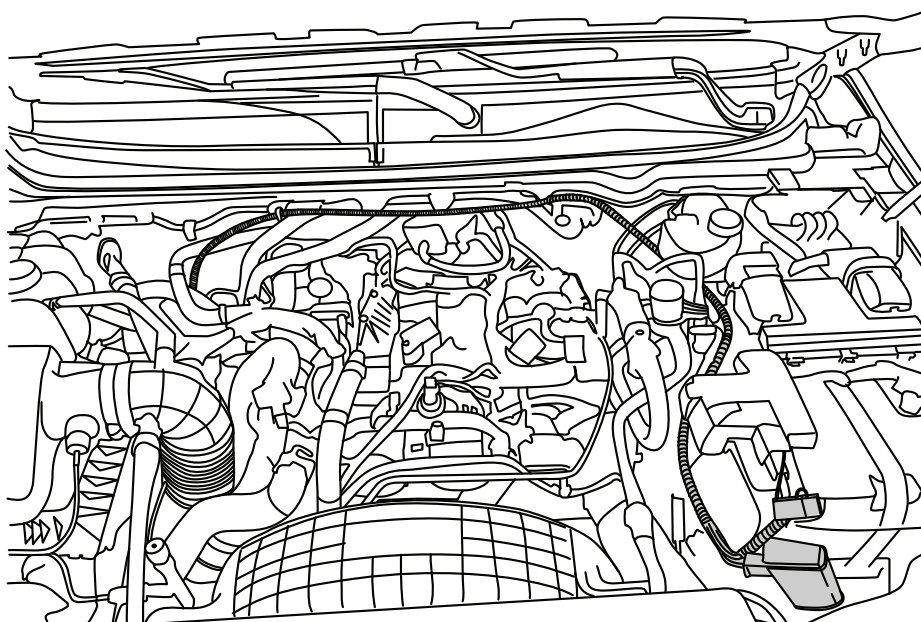

7

Ford Ranger ONLY:

Remove floor mat and sill plate cover to expose floor below.

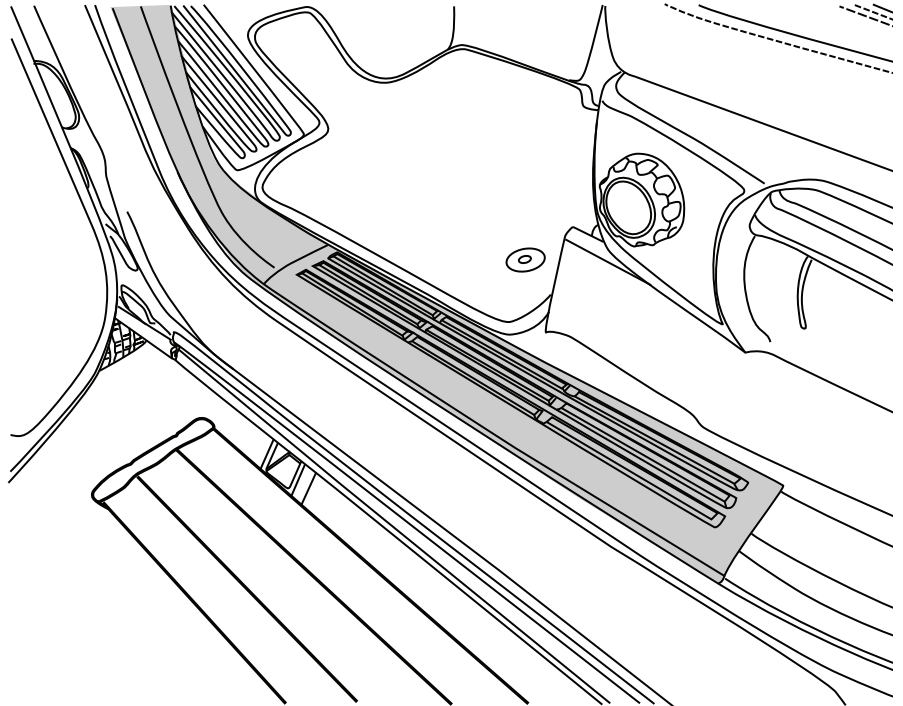

8

Locate hole forward of rubber plug. Approx location is in footwell area of cab. Use a 9/32" drill bit and drill thru floor. While drilling lift carpet to ensure drill bit does not damage carpet inside cab.

Insert provided grommet (14) and run trigger wires thru hole. Route wires towards kick panel area.

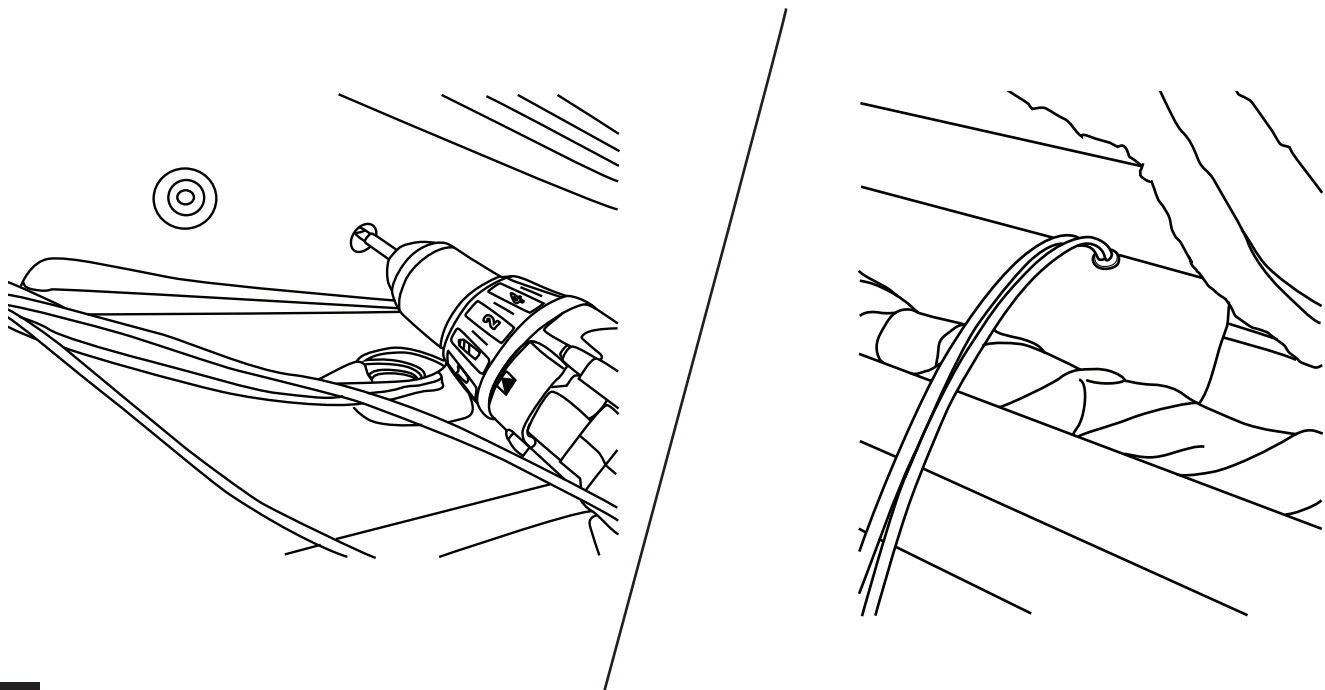

9

**Ford Ranger ONLY:
Bronco proceed to step 13**

Locate OBD port and remove bolt and nut holding it in place with 8mm socket to gain better access to back side of plug.

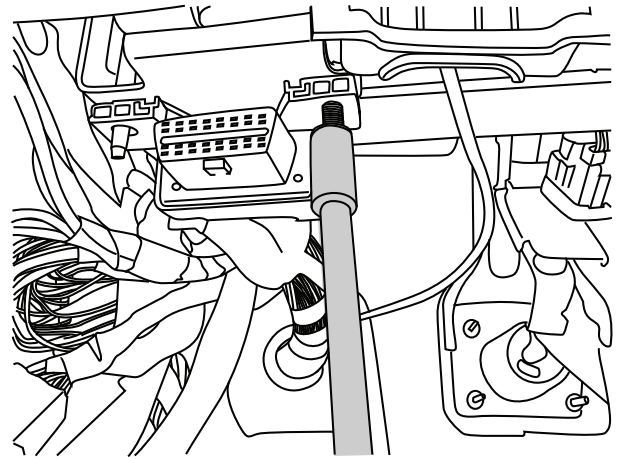

10

Locate the following wires and connect with supplied Posi-Tap™ (10) to the following wire colors listed below.

Factory Can Wire	OBD Module wire Color
Grey with Orange Stripe	White Wire
Purple with Orange Stripe	Blue Wire

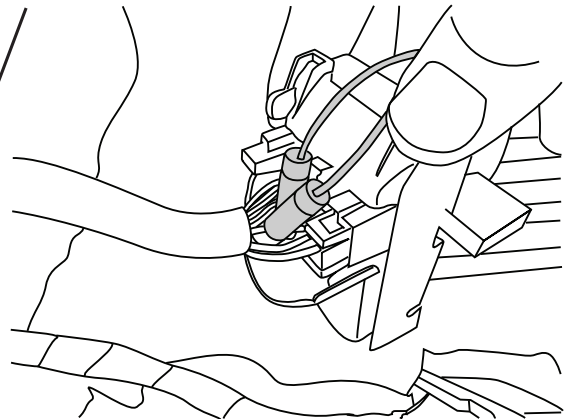
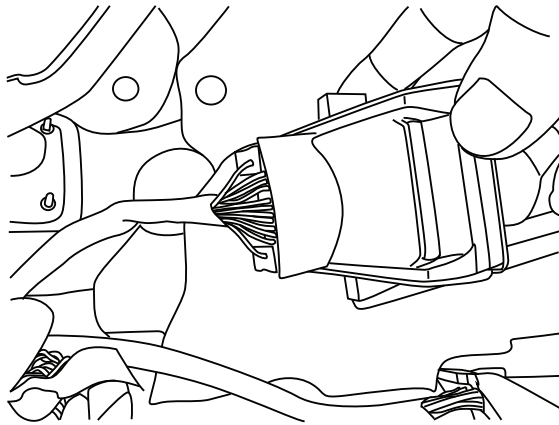

11

Use supplied Posi-Lock™ connectors to attach the 2 purple wires of the obd harness to the main harness. Attach matching colors on the harness to the wires on the module. Lastly reinstall Factory OBD port removed in step 10. Plug in module to OBD port on the vehicle. Reinstall sill plate removed from step 8.

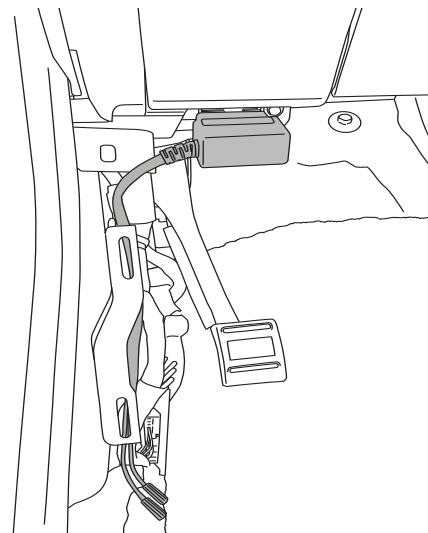

12

IMPORTANT NOTE!

Ford Bronco continue here, step 13.
 Ford Ranger skip to step 17 on page 12 .

Ford Bronco ONLY:

Mount controller using supplied zip ties to harness in front of battery as shown. Connect positive leads from harness. Red to positive battery terminal and black to negative battery terminal.

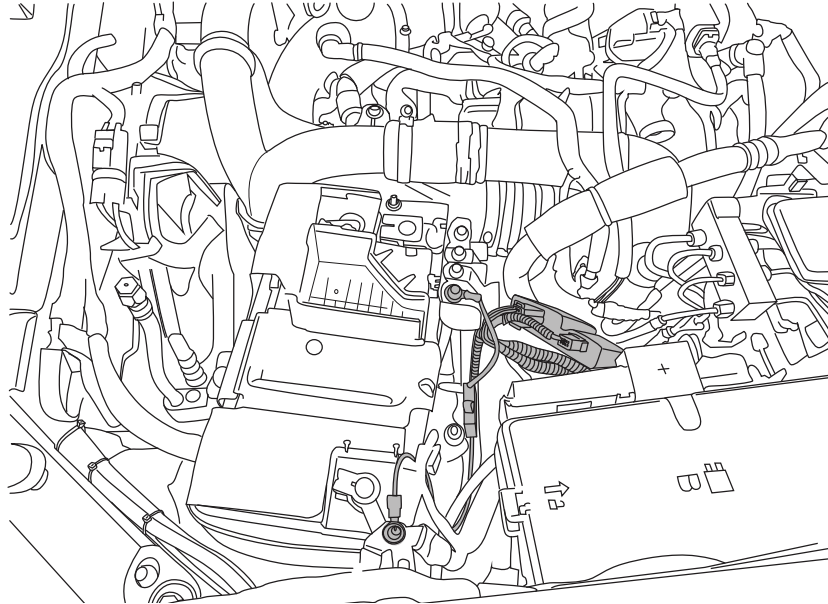

13

Route the two wire harness legs down over to each wheel well. Long leg will run across to passenger side, short leg will run down to driver side. Ensure loom is free from steering and exhaust components.

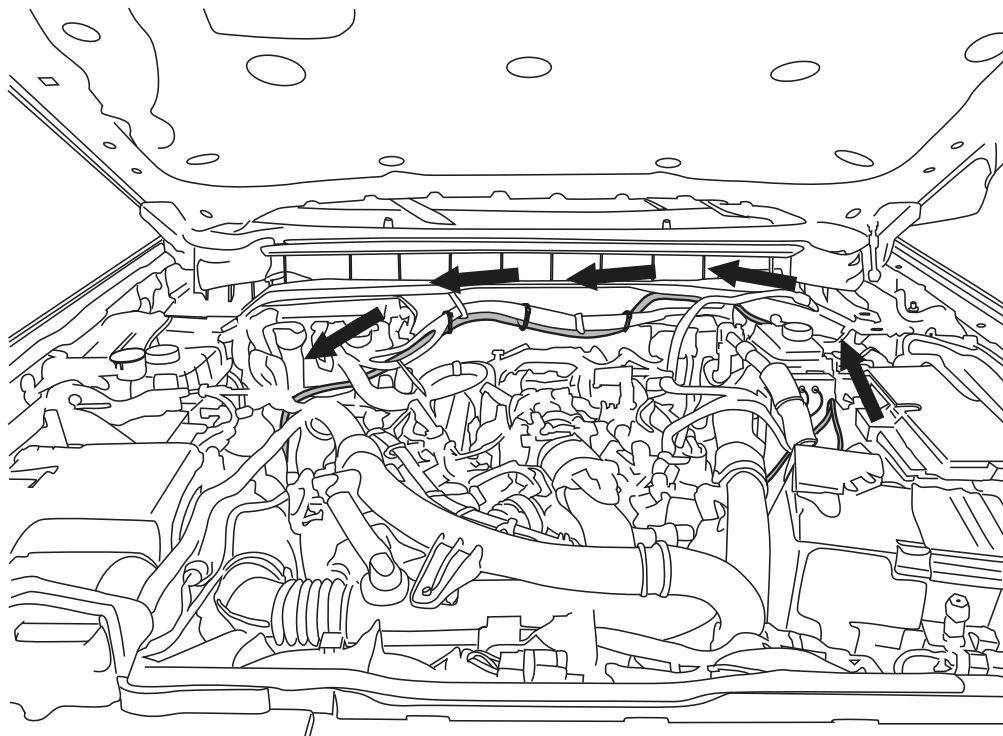

14

Ford Bronco ONLY:

Peel back small conduit with 2 purple wires inside to approx. 8" from junction. Trim excess conduit and tape end. This will allow wires to be exposed beyond the grommet when inserting into the cab of the vehicle. Excess wire will need to be trimmed for this application after being inserted into the vehicle.

Locate oval grommet on driver side of firewall and push out. Poke small hole in grommet and thread trigger wires into cab of vehicle.

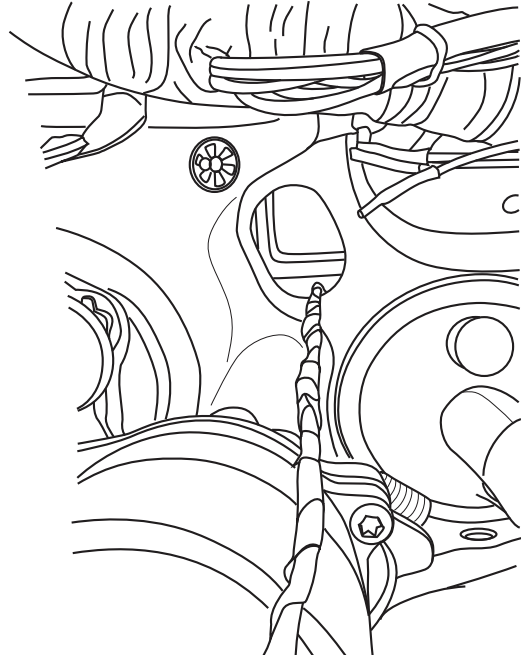
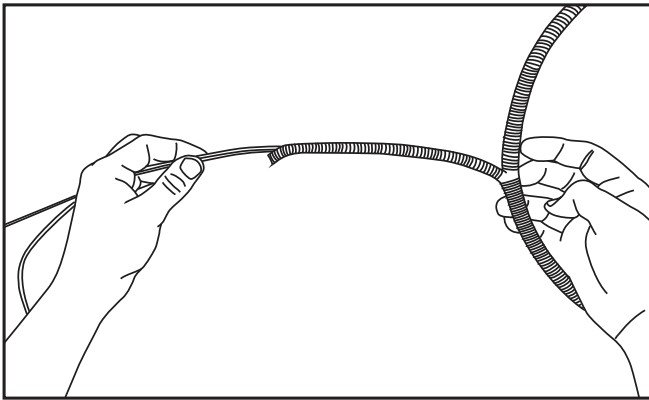

15

Locate the following wires and connect with supplied Posi-Tap™ (10) to the following wire colors listed below.

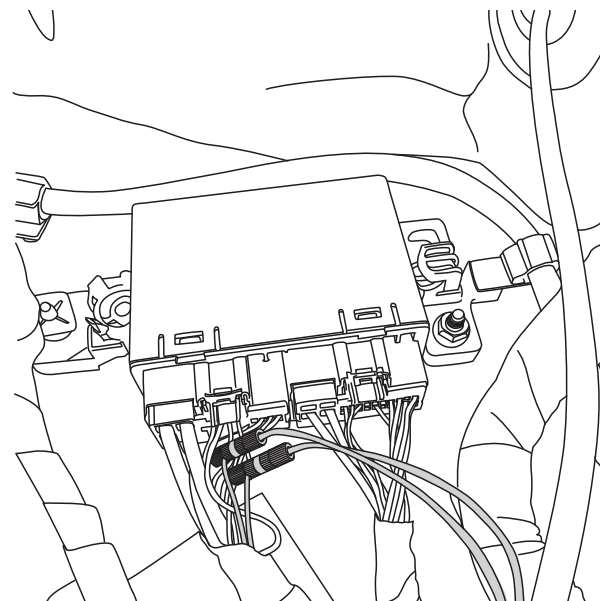

2021 - 2023

Factory Can Wire	OBD Module Wire Color
Grey with Orange Stripe	White Wire
Purple with Orange Stripe	Blue Wire

2024 - 2025

Factory Can Wire	OBD Module Wire Color
Green with Orange Stripe	White Wire
Purple with Orange Stripe	Blue Wire

16

Ford Ranger and Bronco proceed here:

OBD II install: Use Supplied Posi-Lock™ (9) connectors to attach the Plug and Play Module to the Harness. Attach matching colors on the harness to the wires on the module. Plug in module to OBD II port on the vehicle. Secure harness with supplied tie wraps. *Note: If the OBD II pass thru harness (76404-01A) was purchased see install sheet supplied in packaging. The pass through harness allows for an open port for other accessories. See below for a brief description.*

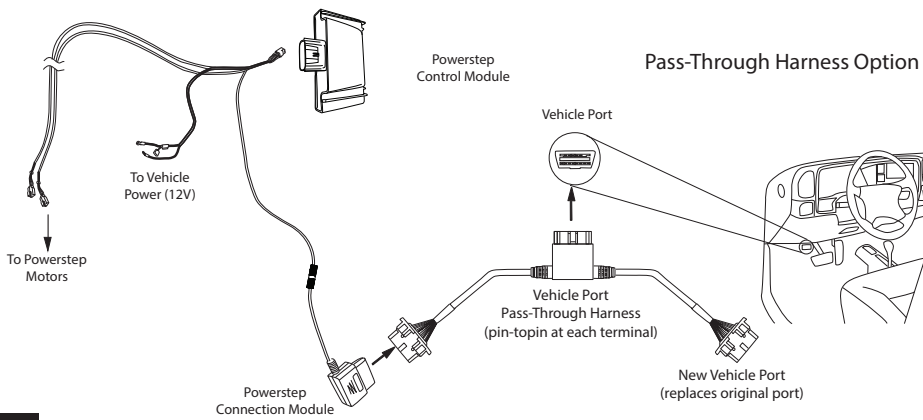
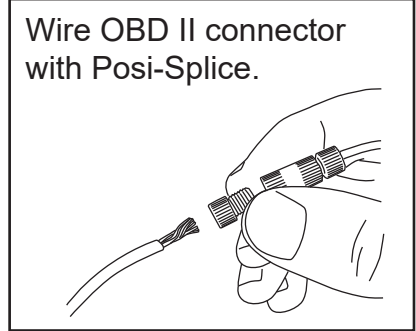
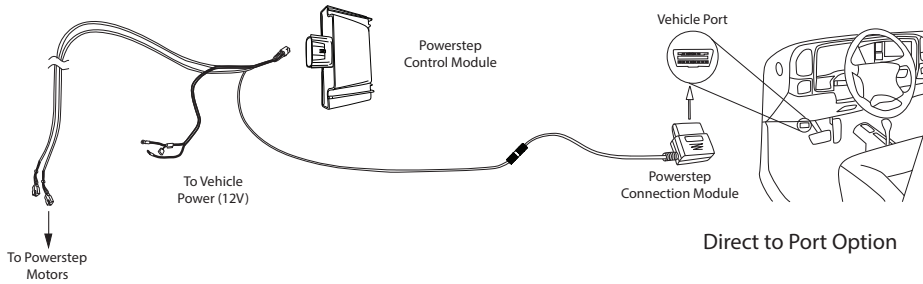

17

For 4 Door Bronco and Ranger. On each side of the vehicle measure from the front edge of door line on the pinch weld to the specified lengths below. Measure at 16" for the front LED Light and 58" for the rear LED Light.

NOTE: For 2 Door Bronco, measure at 16" for front LED Light and 38" for the rear LED Light.

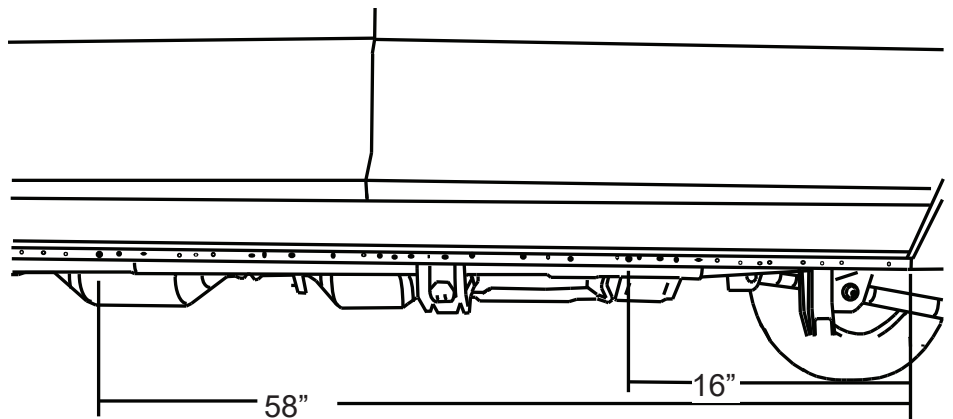

18

Before proceeding, see spin direction of the each motor than proceed with step A or B below.

A. Motor spinning the shaft clockwise direction:

- 1) First, install one Posi-Tite® (16) onto black wire from the motor. See image on right.
- 2) Install second Posi-Tite® (16) onto red with purple stripe wire from motor. See image on right.

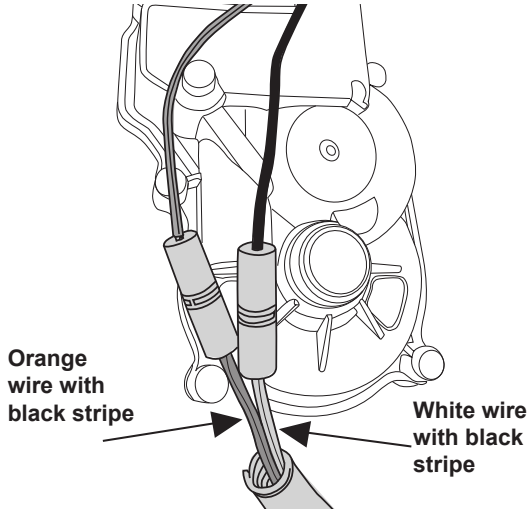

- 3) Next, connect the white wire with black stripe from the wire harness to the other end of the Posi-Tite® (16) that is connected to the all black wire from first step above.
- 4) Connect the Posi-Tite® (16) the red with purple stripe wire from the motor with the orange with black stripe wire from the harness.

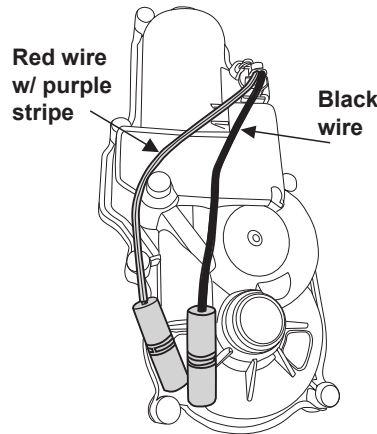

Posi-Tite® Instructions

1. Strip 3/8"



2. Push



3. Tighten



B. Motor spinning the shaft counter clockwise direction:

- 1) First, install one Posi-Tite® (16) onto black wire from the motor. See image on right.
- 2) Install second Posi-Tite® (16) onto Red wire with purple stripe from motor. See image on right.

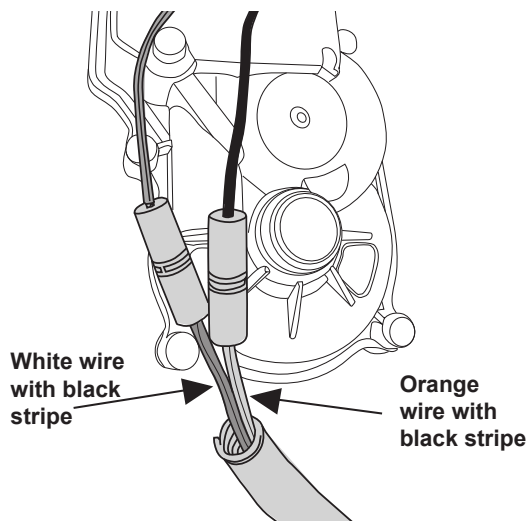

- 3) Next, connect the orange wire with black stripe from the wire harness to the other end of the Posi-Tite® (16) that is connected to the all black wire from first step above.
- 4) Connect the Posi-Tite® (16) the red wire with purple stripe from the motor with the white with black stripe wire from the harness.

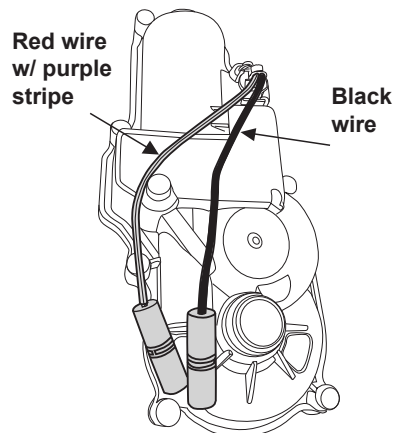

Posi-Tite® Instructions

1. Strip 3/8"



2. Push



3. Tighten



- Drill a 9/32" hole through the pinch weld at marked locations. Deburr all holes. After drilling apply paint to holes to prevent rusting.

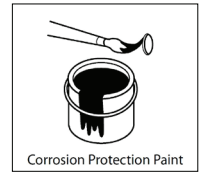
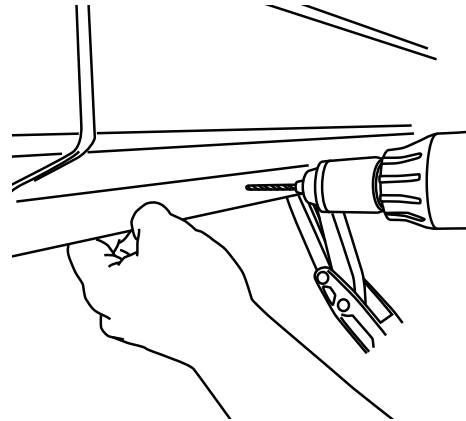

20

- Insert grommet into drilled holes. Insert lamp wires through the grommets. (Silicon lube will help wires slip through grommets).

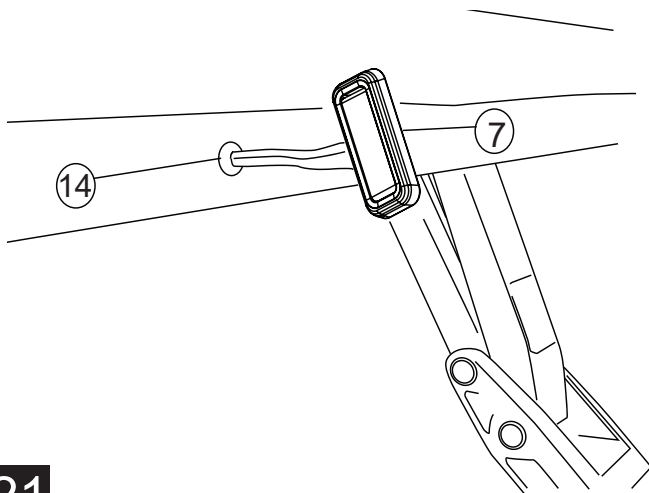

- Affix lamp to rocker panel surface. Make sure lamp is affixed to a flat, clean surface.

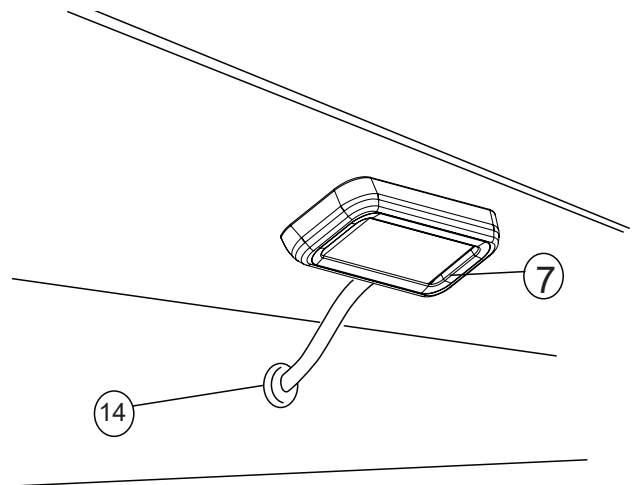

21

22

Using supplied butt connectors (15), connect the lamp wires. Red to Red, Black to Black. Once Crimped use heat gun to shrink tube. Close and wrap with conduit and electrical tape. Secure all loose wires with cable ties, with lamp wires pulled upward to avoid any wire snagging.

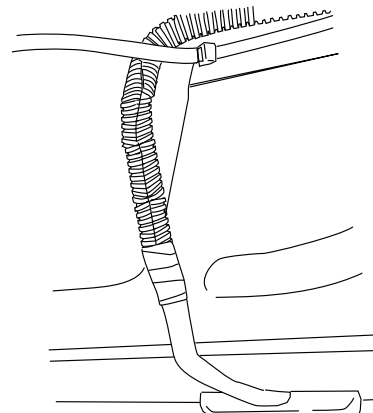
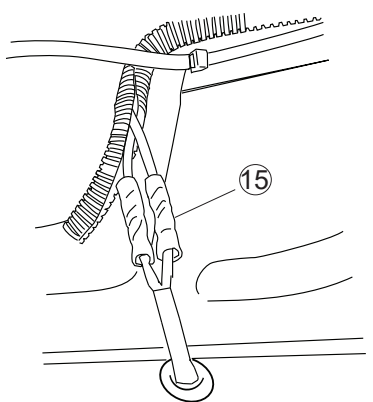

23

Reinstall Fuse. Check that all doors activate the Power Step and the LED Lights work when doors open and close. Reinstall any remaining trim panels.

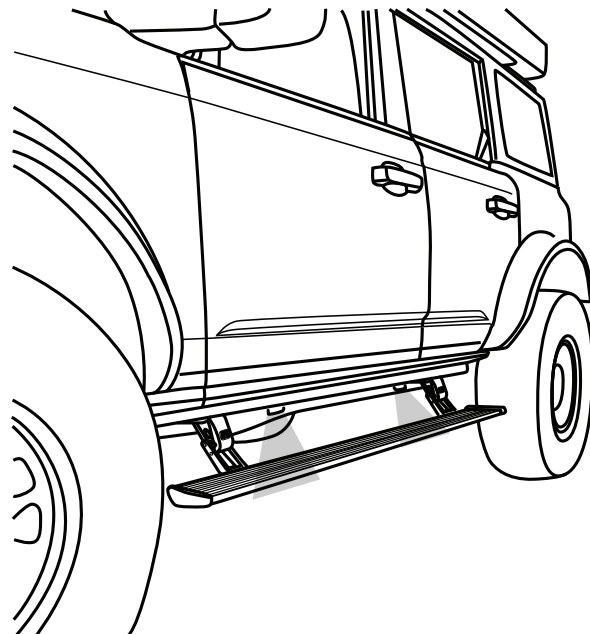
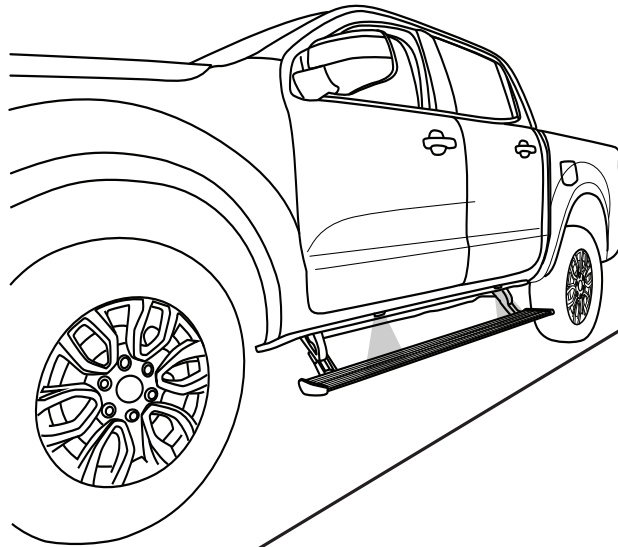
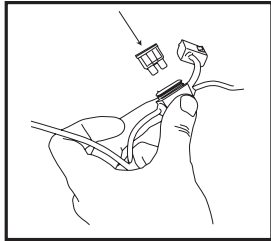

FINAL SYSTEM CHECK

Check that all doors activate the PowerStep and the LED lights work when doors open and close.

NORMAL OPERATION: When the doors open, PowerStep automatically deploys from under the vehicle. When the doors are closed, PowerStep will automatically return to the stowed/retracted position.

Note that there is a 2-second delay before the PowerStep returns to the stowed/retracted position.

CORRECT OPERATION OF LIGHTS: All four lamps will illuminate upon opening any door of vehicle. Lamps will stay on until restowing of both Power Steps or until 5 minutes has expired with the doors open. When the lights timeout after 5 minutes, they can be reilluminated by closing and opening any door of vehicle.



AMERICAN DESIGNED & ENGINEERED

Thank you for your recent RealTruck purchase.

REGISTER YOUR PRODUCT TODAY FOR FASTER SERVICE & PRODUCT UPDATES

Please visit:

<https://realtruck.com/warranty-registration/>
or scan the QR Code



Product Registration Benefits:

- Ensure we have your purchase receipt and product info in our system which is required for warranty.
- Faster and easier access to customer service and tech support in the unlikely event you need warranty or product support.
- Registration helps us keep you up to date on product information and offers.

To view other RealTruck products that may be offered for your vehicle.

Please visit: www.realtruck.com

Rev 05.30.24

Congratulations on your purchase of the genuine RealTruck / AMP Research PowerStep! Here's what you should know...

POWER-DEPLOYABLE RUNNING BOARDS OPERATION: RealTruck / AMP Research PowerStep running boards automatically move when the doors are opened to assist entering and exiting the vehicle.

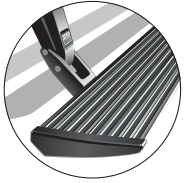

Automatic power deploy:

The running boards will extend down and out when the doors are opened.

Automatic power stow:

The running boards will return to the stowed position when the doors are closed. There will be a 2-second delay before the running boards move to the stowed position.

Automatic stop:

If an object is in the way of the moving running board, the running board will automatically stop. To reset, clear any obstruction, then simply open and close the door to resume normal operation.



Manually set in the deployed (OUT) position for access to the roof:

The running boards can be manually set in the deployed position by firmly holding the step down with your foot while at the same time closing the door. To resume normal operation, open and close the door.

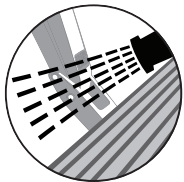

Maintenance: In adverse conditions, debris such as mud, dirt, and salt may become trapped in the running board mechanism, possibly leading to unwanted noise. If this occurs, manually set the running boards to the deployed position and flush the front and rear hinge arms with a high-pressure car wash wand. Avoid spraying the motors directly. After washing, apply silicone spray lubricant to the hinge pivot pins. Do not apply silicone, wax or protectants like Armor All® to the running board stepping surface.

Caution! Keep hands away when the running board is in motion.

5-YEAR LIMITED WARRANTY

RealTruck / AMP RESEARCH warrants this product to be free from defects in material and workmanship for FIVE (5) YEARS FROM DATE OF PURCHASE, provided there has been normal use and proper maintenance. This warranty applies to the original purchaser only. All remedies under this warranty are limited to the repair replacement of the product itself, or the repair or replacement of any component part thereof, found by the factory to be defective within the time period specified. The decision to repair or replace is wholly within the discretion of the manufacturer.

This warranty specifically excludes labor. If you have a warranty claim, first you must call our factory at the number below for instructions. You must retain proof of purchase and submit a copy with any items returned for warranty work. Upon completion of warranty work, if any, we will return the repaired or replaced item or items to you freight prepaid. Damage to our products caused by accidents, fire, vandalism, negligence, misinstallation, misuse, acts by nature or by defective parts not manufactured by us, is not covered under this warranty.

ANY IMPLIED WARRANTIES OF MERCHANTABILITY AND/OR FITNESS FOR A PARTICULAR PURPOSE CREATED HEREBY ARE LIMITED IN DURATION TO THE SAME DURATION AND SCOPE AS THE EXPRESS WRITTEN WARRANTY. OUR COMPANY SHALL NOT BE LIABLE FOR ANY INCIDENTAL OR CONSEQUENTIAL DAMAGE.

Some states do not allow limitations on how long an implied warranty lasts, or the exclusion or limitation of incidental or consequential damages, so the above limitations or exclusions may not apply to you. This warranty gives you specific legal rights, and you may also have other rights that vary from state to state.

FOR WARRANTY ISSUES WITH THIS PRODUCT PLEASE CALL REALTRUCK TECH SUPPORT 1-888-983-2204

WARNING

Be sure to read and precisely follow the provided instructions when installing this product. Failure to do so could place the vehicle occupants in a potentially dangerous situation. After installing or reinstalling, re-check to insure that the product is properly installed.