

PARTS LIST:

1	Bull Bar	6	10mm x 35mm Hex Bolts
1	Driver/Left Mounting Bracket	14	10mm x 30mm OD x 2.5mm Flat Washers
1	Passenger/Right Mounting Bracket	8	10mm Lock Washers
1	Driver/Left Support Bracket	8	10mm Hex Nuts
1	Passenger/Right Support Bracket	2	10mm Fish Wires
2	10mm x 35mm Bolt Plates		

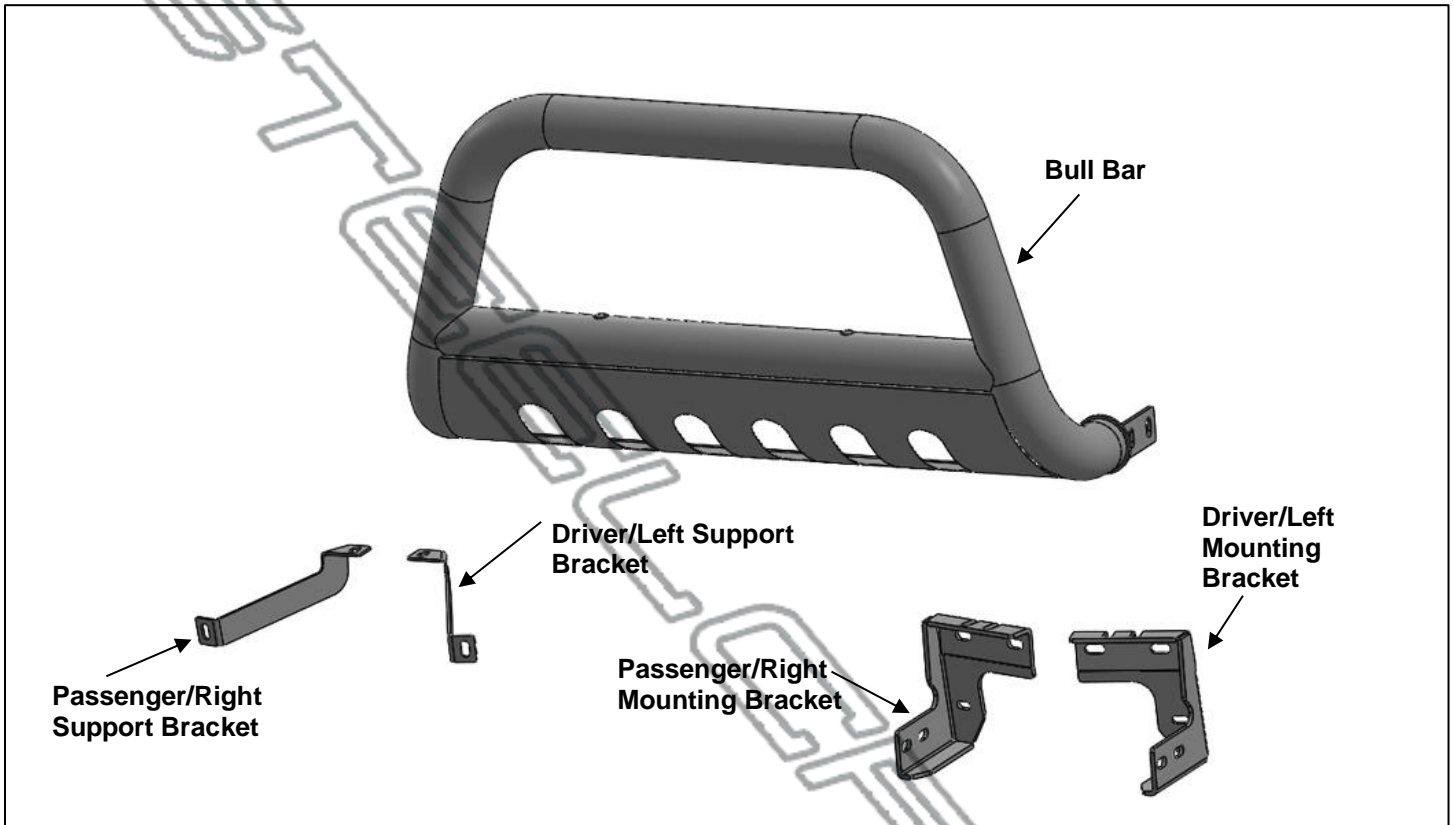

PROCEDURE:

REMOVE CONTENTS FROM BOX. VERIFY ALL PARTS ARE PRESENT. READ INSTRUCTIONS CAREFULLY BEFORE STARTING INSTALLATION. INSTALLATION MAY INTERFERE WITH FRONT MOUNTED SENSORS.

1. Start installation under the Passenger/Right front side of the vehicle. Locate the end of the frame just behind the bumper and temporarily remove the (4) factory bolts, **(Figure 1)**.
2. Select the Passenger/Right Mounting Bracket. Reuse the factory bolts to attach the Mounting Bracket to the frame, **(Figure 2)**. Do not tighten hardware.
3. Repeat **Step 1** to attach the Driver/Left Mounting Bracket.
4. Select the Bull Bar. Attach the Bull Bar to the (2) Mounting Brackets with (4) 10mm Hex Bolts, (8) 10mm Flat Washers, (4) 10mm Lock Washers and (4) 10mm Hex Nuts, **(Figures 3 & 4)**. Do not tighten hardware.
5. Select (1) 10mm Bolt Plates and (1) 10mm Fish Wire. Thread the Fish Wire onto the Bolt Plate, **(Figure 5)**. Insert the end of the Fish Wire into the large hole and guide the Bolt Plate through the smaller hole towards the side of the vehicle, **(Figures 6 & 7)**.
6. Select the Passenger/Right Support Bracket. Attach the Support Bracket to the Bolt Plate with (1) 10mm Flat Washer, (1) 10mm Lock Washer and (1) 10mm Hex Nut, **(Figure 8)**. Attach the Support Bracket to the Mounting Bracket with (1) 10mm Hex Bolt, (2) 10mm Flat Washers, (1) 10mm lock Washer and (1) 10mm Hex Nut, **(Figures 9 & 10)**. Do not tighten hardware.
7. Repeat **Steps 5 & 6** to attach the Driver/Left Support Bracket to the frame and Mounting Bracket.

8. Level and adjust the Bull Bar, then tighten all hardware.
9. Do periodic inspections to the installation to make sure that all hardware is secure and tight.

To protect your investment, wax this product after installing. Regular waxing is recommended to add a protective layer over the finish. Do not use any type of polish or wax that may contain abrasives that could damage the finish. Mild soap may be used to clean the Bull Bar.

Passenger/Right Side Installation Pictured

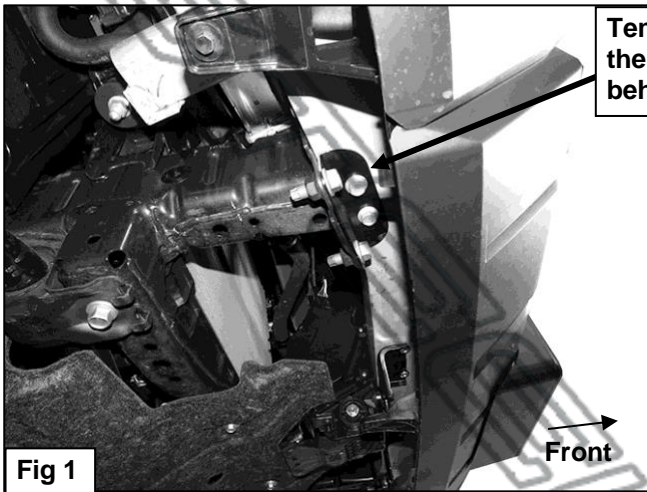

Temporarily remove the (4) bolts located behind the bumper

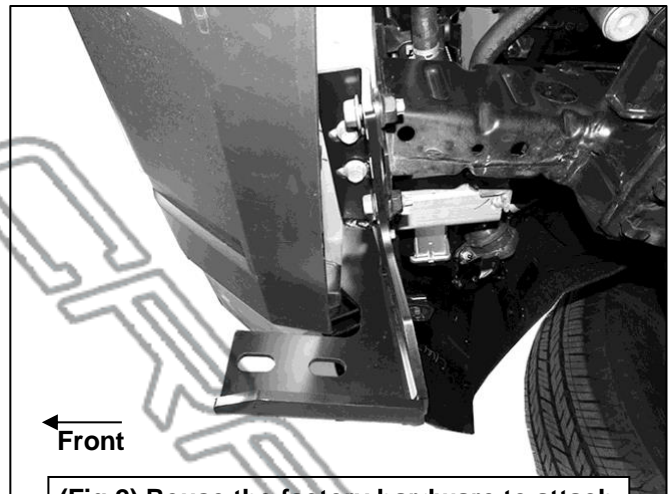

(Fig 2) Reuse the factory hardware to attach the Passenger/Right Mounting Bracket

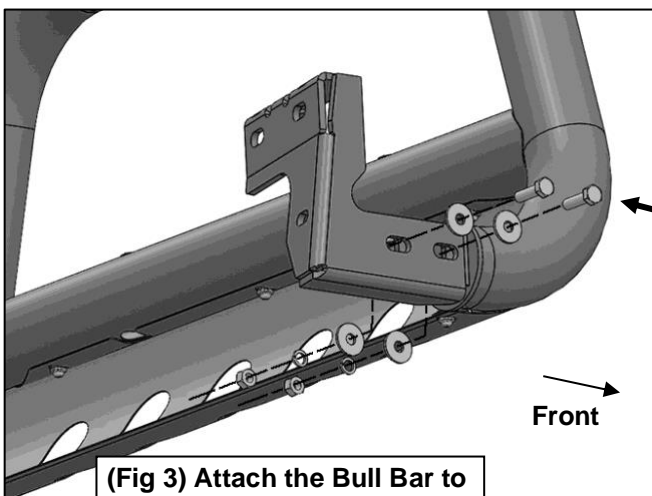

(Fig 3) Attach the Bull Bar to the (2) Mounting Brackets

- (2) 10mm Hex Bolts
- (4) 10mm Flat Washers
- (2) 10mm Lock Washers
- (2) 10mm Hex Nuts

Passenger/Right Side Installation Pictured

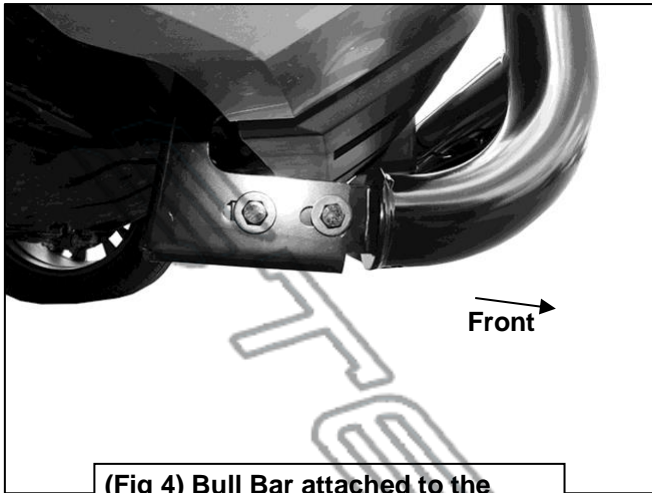

(Fig 4) Bull Bar attached to the Passenger/Right Mounting Bracket

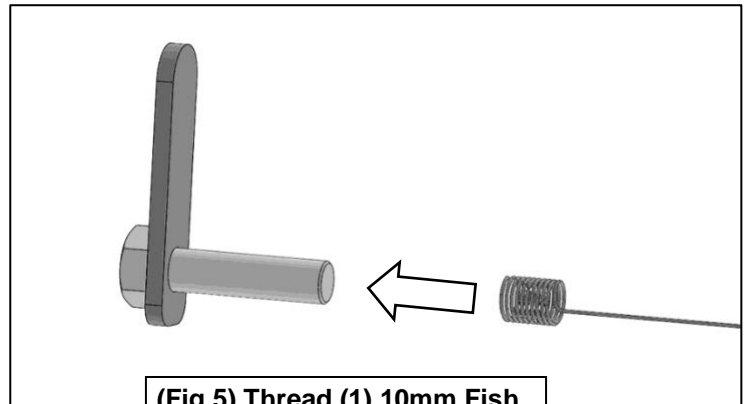

(Fig 5) Thread (1) 10mm Fish Wire onto (1) 10mm Bolt Plate

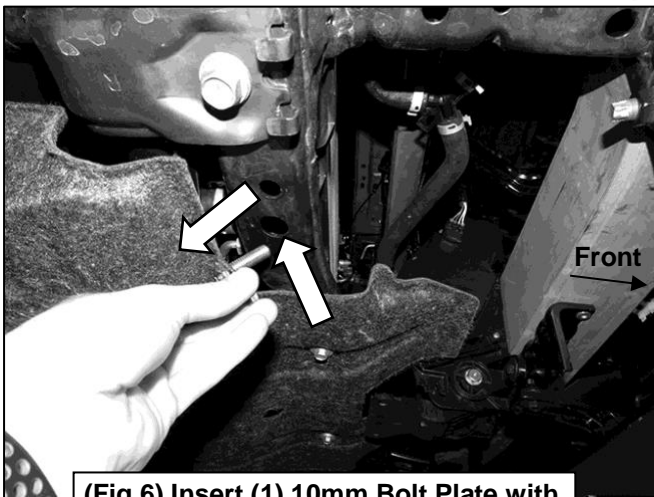

(Fig 6) Insert (1) 10mm Bolt Plate with Fish Wire into the large hole the crossmember and out the smaller hole towards the side of the vehicle

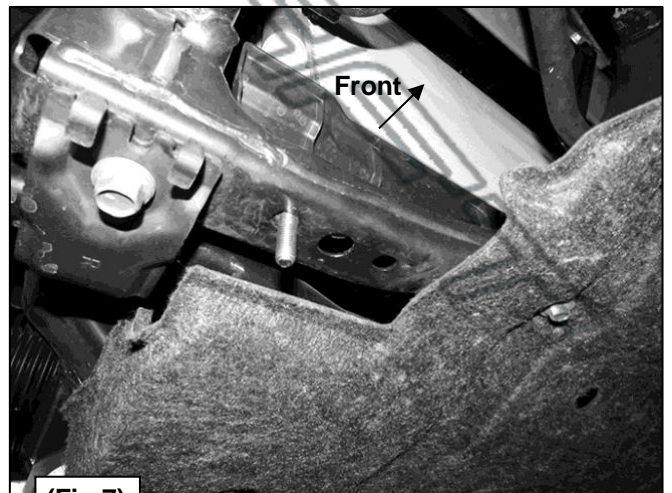

(Fig 7)

Passenger/Right Side Installation Pictured

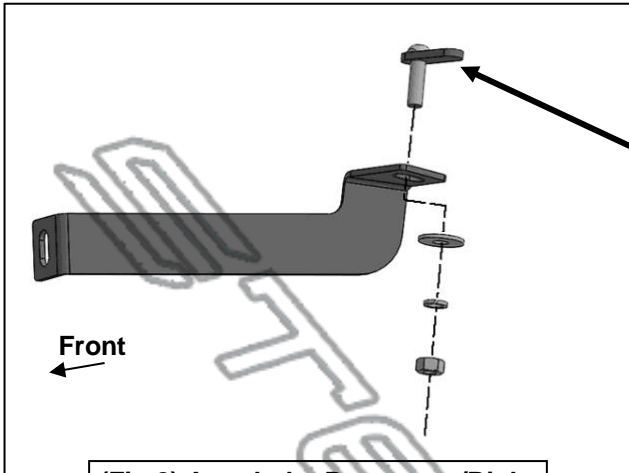

- 10mm Bolt Plate
- 10mm Flat Washer
- 10mm Lock Washer
- 10mm Hex Nut

(Fig 8) Attach the Passenger/Right Support Bracket to the Bolt Plate

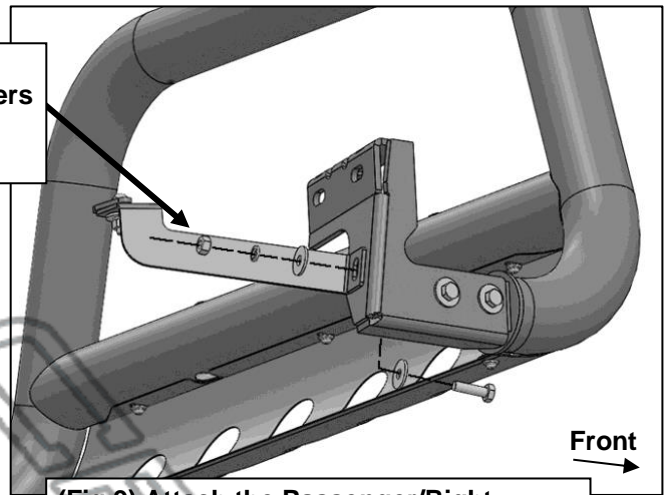

- 10mm Hex Bolt
- (2) 10mm Flat Washers
- 10mm Lock Washer
- 10mm Hex Nut

(Fig 9) Attach the Passenger/Right Support Bracket to the Mounting Bracket

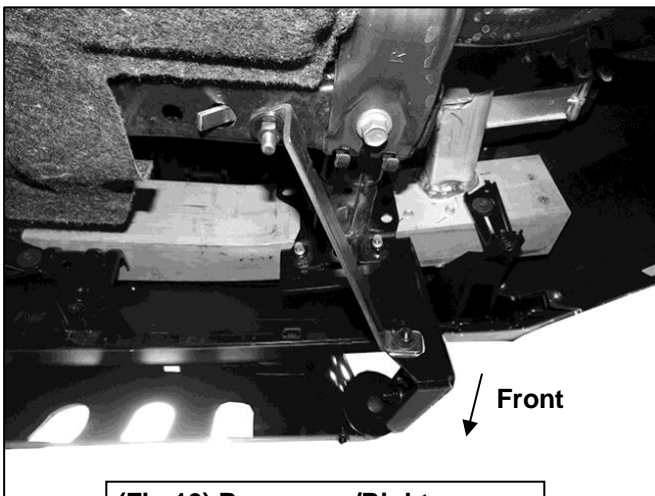

(Fig 10) Passenger/Right Support Bracket attached to the frame and Mounting Bracket