



TEL: 1-866-XANATOS

INSTALLATION INSTRUCTIONS

**MODULAR RUGGED GRILLE GUARD
2018-2023 FORD EXPEDITION
PART# RU-FOEX18-B**

PARTS LIST:

1	Main Body	2	12-1.75mm Double Nut Plate
1	Passenger/Right Brush Guard	4	12-1.75 x 55mm Hex Bolt
1	Driver/Left Brush Guard	4	12-1.75 x 40mm Hex Bolt
1	Driver/left Frame Bracket	12	12mm x 32mm OD x 3mm Flat Washer
1	Passenger/right Frame Bracket	4	12mm Lock Washer
2	LED lamp Bracket	4	12mm Nylon Lock Nuts
22	8mm x 24mm OD x 2mm Flat Washers	1	2.5mm Wrench
12	8mm x 25mm Button Head Allen Screws	1	5mm Wrench
10	8mm Nylon Lock Nuts		
2	8mm Lock Washer		

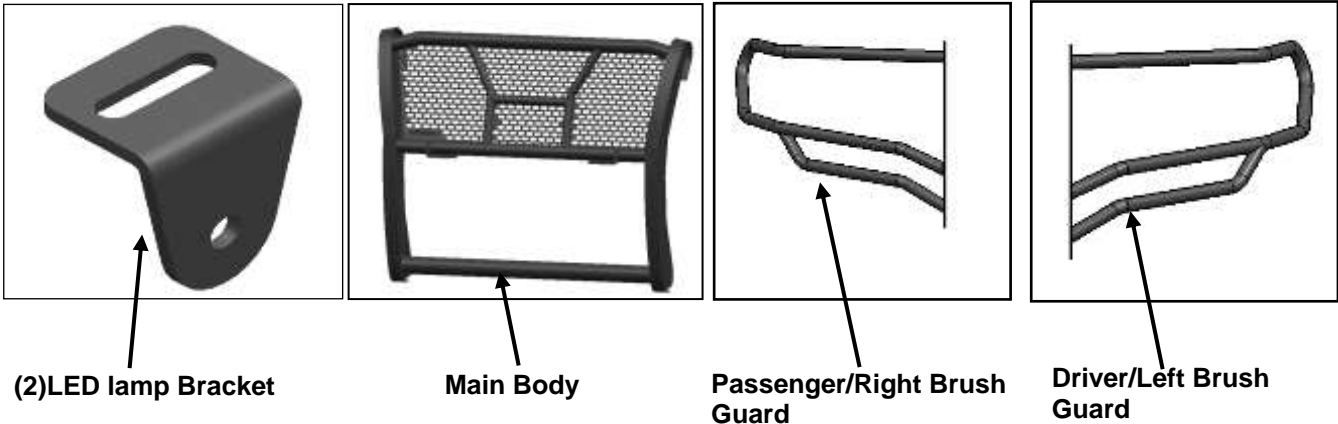
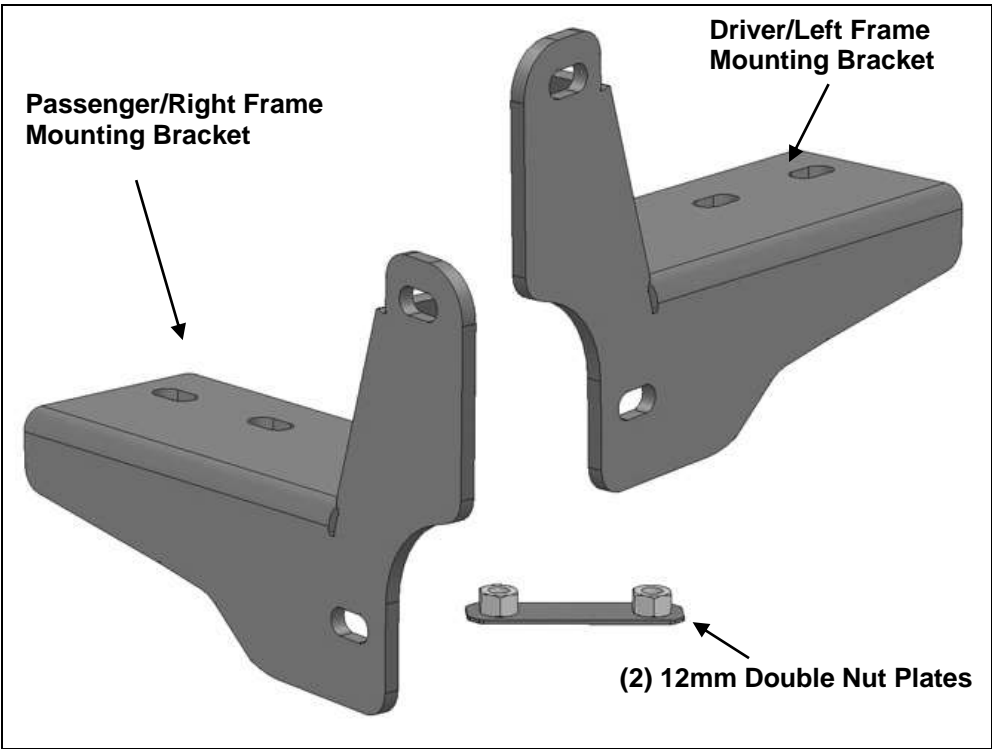

Please Noted:

1. Before you install the Grille Guard on the vehicle, please install the Driver/Left Brush Guard and Passenger/Right Brush Guard on the main body first.
2. Before you install the LED Lamp on the main body please install the LED Lamp Bracket first.
3. If you are not going to install a LED Lamp, the LED Lamp Bracket installation is unnecessary. For main body installation follow the instruction as bellow.

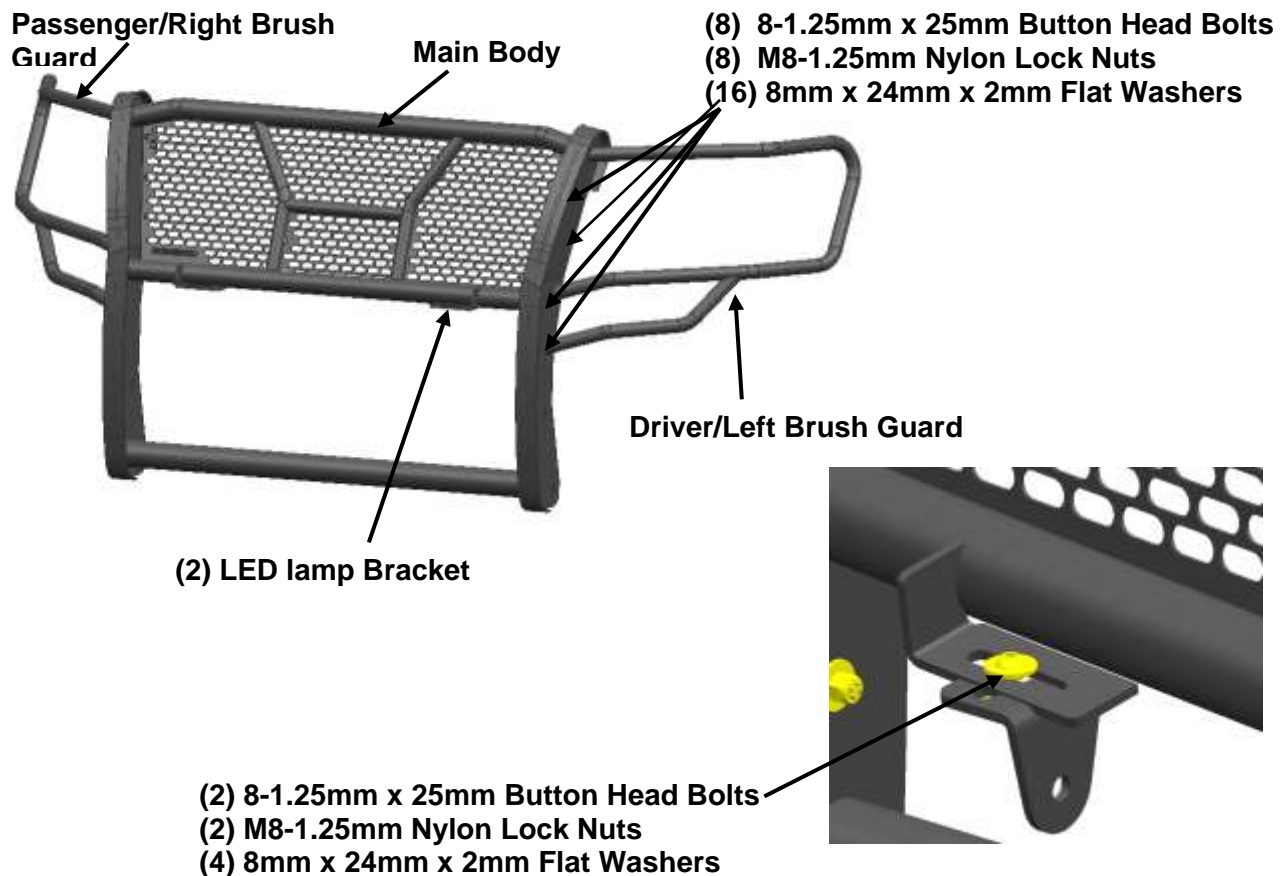

IMPORTANT: The Grille Guard is designed to tilt forward to clear the attached grille on 2007-13 Tundra, 08-14 Sequoia models. To tilt the Grille Guard, the Quick Release Bolts on the Top Brackets must be released and the upper bolts on both Mounting Brackets may need to be loosened slightly. Make sure that all hardware is fully tightened after closing the hood. Carefully read Page 8, "Opening and Closing of Hood," before installing the Grille Guard.

PROCEDURE:

REMOVE CONTENTS FROM BOX. VERIFY ALL PARTS ARE PRESENT. READ INSTRUCTIONS CAREFULLY BEFORE STARTING INSTALLATION. ASSISTANCE IS RECOMMENDED.

1. Start installation at the driver/left front of the vehicle. Remove the plastic panel from the bumper, **(Figures 1 & 2)**. On models with tow hooks, the panel surrounds the tow hook.
2. Determine if the vehicle is equipped with factory tow hooks, **(Figure 1)**.

Frame Bracket Installation on vehicles with Factory Tow Hooks:

- a. Remove the driver/left tow hook, **(Figure 3)**. **NOTE:** Leave the factory double nut plate in position inside the frame, **(Figure 4)**.
- b. Select the driver/left Frame Mounting Bracket, **(Figure 6)**. Insert the Bracket between the tow hook and the frame.

- c. Reattach the tow hook over the Bracket with the factory bolts, **(Figure 7)**. Leave hardware loose.
- d. Repeat previous **Steps** to install the passenger/right Frame Bracket.

Frame Bracket Installation on Models without Tow Hooks:

- a. Insert (1) 12mm Double Nut Plate into the end of the driver/left side of the frame, **(Figures 4 & 5)**. Use a 12mm hex bolt to line up the Nut Plate with the holes in the bottom of the frame.
 - b. Select the driver/left Frame Mounting Bracket. Attach the Bracket to the bottom of the frame and Nut Plate with the included (2) 12mm x 55mm Hex Bolts, (2) 12mm Lock Washers and (2) 12mm Flat Washers, **(Figure 6)**. Leave hardware loose at this time.
 - c. Repeat the previous **Steps** for passenger/right Frame Mounting Bracket installation.
3. With assistance, place the Grille Guard up to the outside of the Brackets. Attach the Grille Guard to the Frame Brackets with (4) 12mm x 40mm Hex Bolts, (8) 12mm Flat Washers and (4) 12mm Nylon Lock Nuts, **(Figure 8)**. Snug but do not tighten hardware at this time.
 4. Center the Grille Guard on the vehicle. Once properly adjusted, fully tighten all hardware.
 5. On models with grille mounted factory camera, remove screen covering opening in Grille Guard, **(Figure 9)**.
 6. Do periodic inspections to the installation to make sure that all hardware is secure and tight.

To protect your investment, Do not use any type of polish or wax that may contain abrasives that could damage the finish. Mild soap may be used to clean the Grille Guard.

Driver Side Installation Pictured



**(Fig 1) Remove plastic cover
(model with tow hook pictured)**

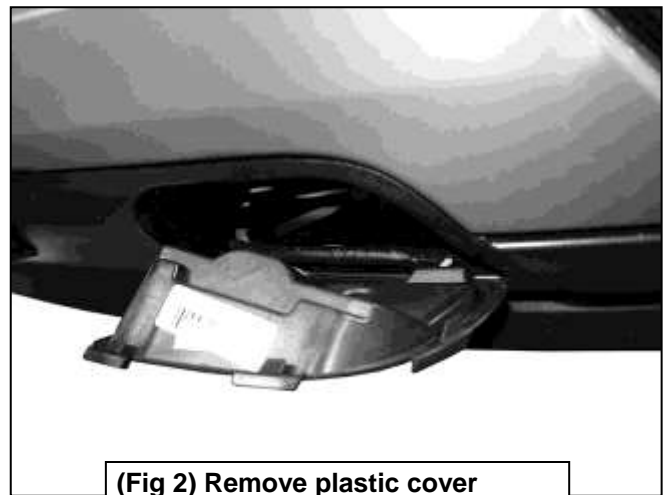

**(Fig 2) Remove plastic cover
(model without tow hook pictured)**

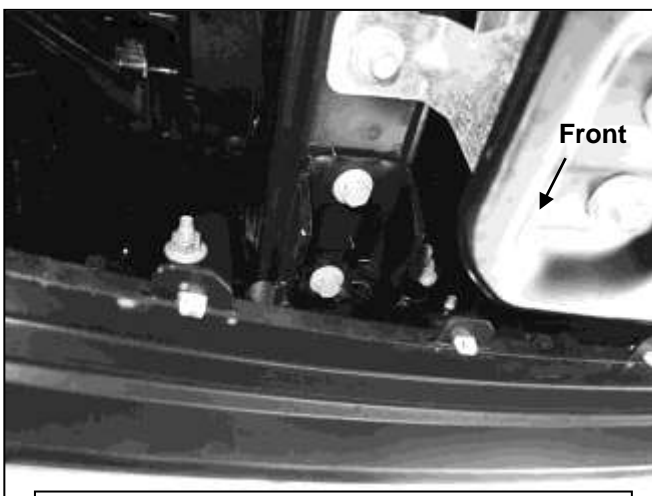

**(Fig 3) Remove tow hook. Mounting location
pictured from below/behind bumper**

Driver Side Installation Pictured



(Fig 5) 12mm Double Nut Plate

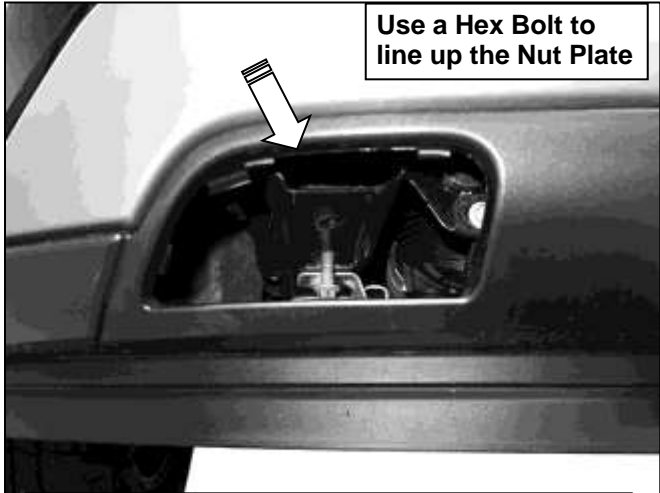

(Fig 4) Models with tow hooks, leave factory double nut plate in frame. Models without tow hooks, insert 12mm Double Nut Plate (Fig 5) into opening in frame (arrow)

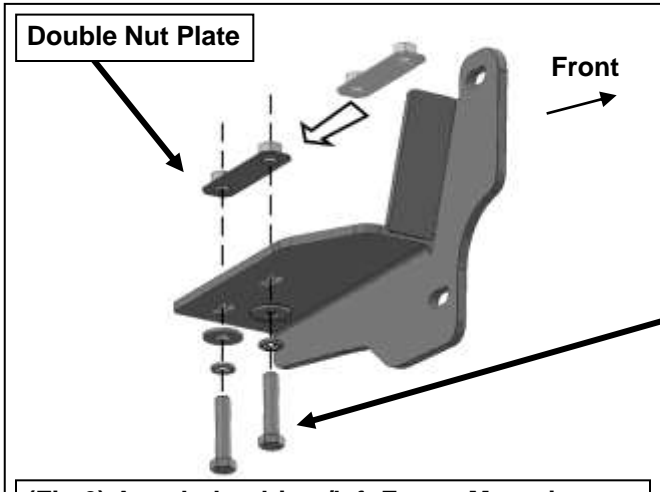

(Fig 6) Attach the driver/left Frame Mounting Bracket to the Double Nut Plate. NOTE: Models with tow hook, reuse factory hardware

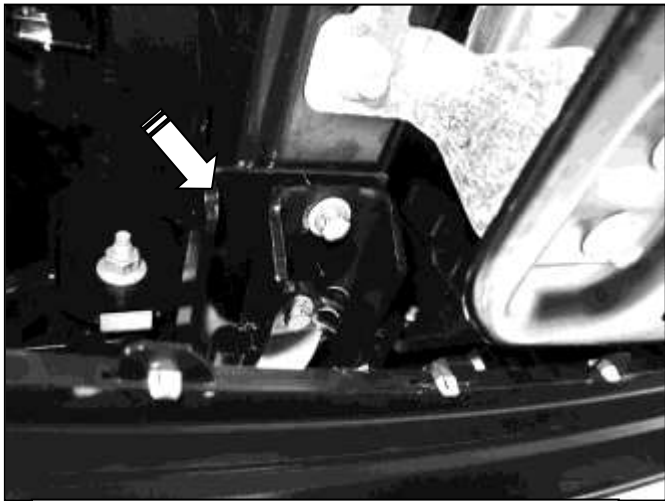

(Fig 7) Attach the driver/left Frame Mounting Bracket to the bottom of the frame. Reinstall tow hook (if equipped) over the Bracket

Driver Side Installation Pictured

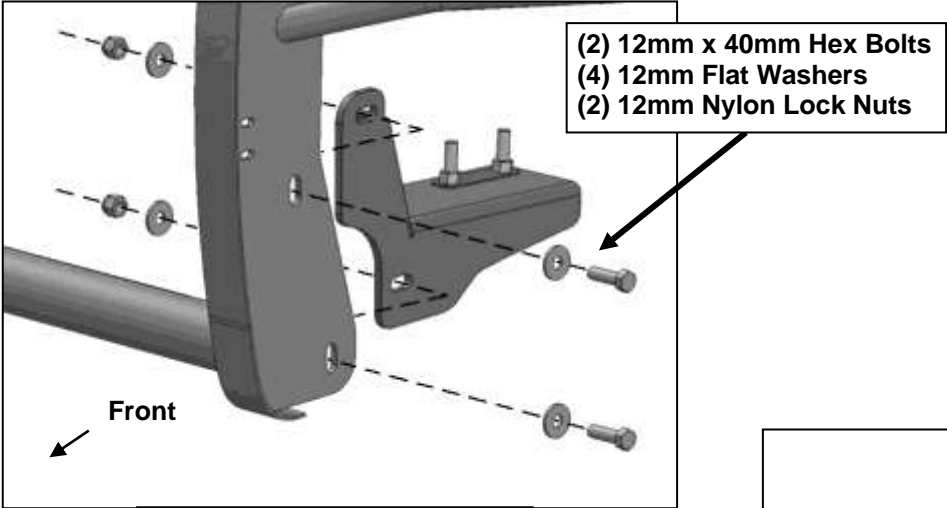

(Fig 8) Attach Grille Guard to outside of Frame Brackets

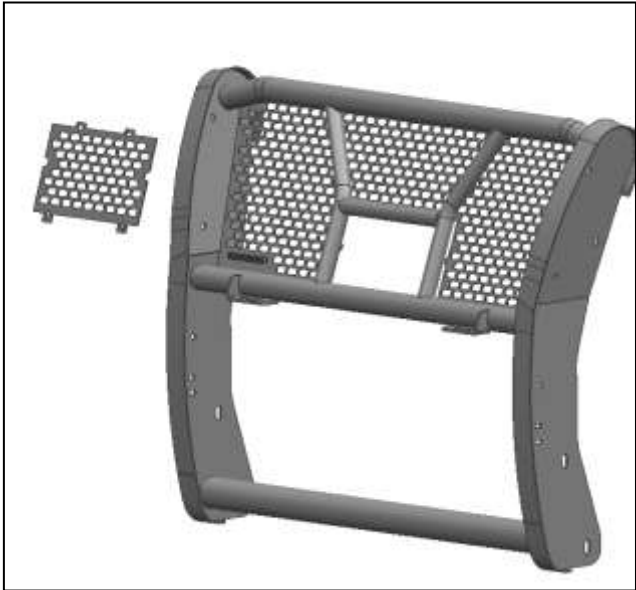

(Fig 9) Remove screen from grille for models with grille mounted camera