



TEL: 1-866-XANATOS

INSTALLATION INSTRUCTIONS

**MODULAR RUGGED GRILLE GUARD FOR
07-13 CHEVY SILVERADO 1500
PART#RU-CHSI07-B**

PARTS LIST:

1	Main Body	28	12mm x 37mm OD x 3mm Large Flat Washers
1	Driver/Left Brush Guard	8	12-1.75mm x 40mm Hex Bolts
1	Passenger/Right Brush Guard	6	12-1.75mm x 35mm Hex Bolts
2	LED Lamp Bracket	14	12mm Lock Washers
1	Driver/Left Top Bracket	14	12mm Hex Nuts
1	Passenger/Right Top Bracket	4	8-1.25mm x 25mm Button Head Bolts
2	Frame Mounting Brackets	4	8mm Lock Washers
2	Lower Frame Support Brackets	8	8mm x 24mm x 2mm Flat Washers
18	8mm x 24mm x 2mm Flat Washers	4	8mm Hex Nuts
10	8-1.25mm x 25mm Button Head Bolts	1	5mm Allen Wrench
8	M8-1.25mm Nylon Lock Nuts	2	Adhesive Backed Foam Tapes

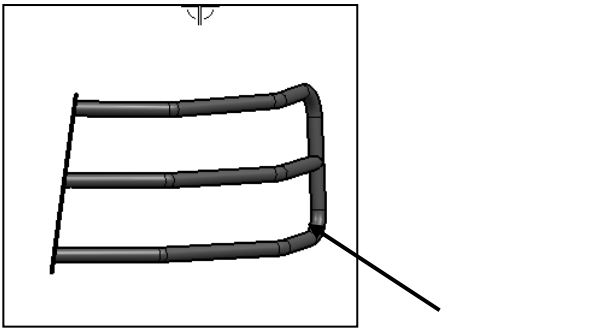
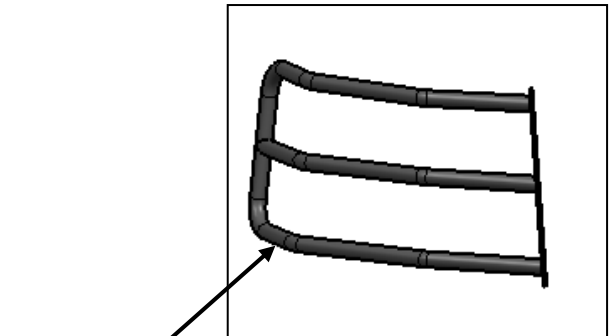
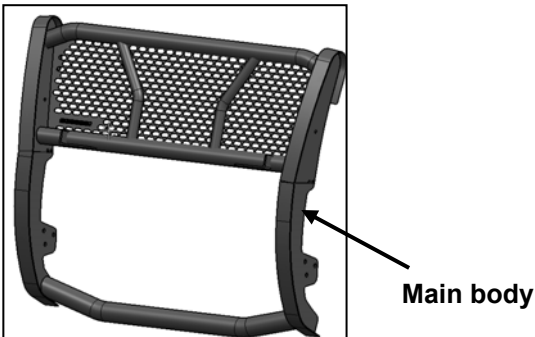
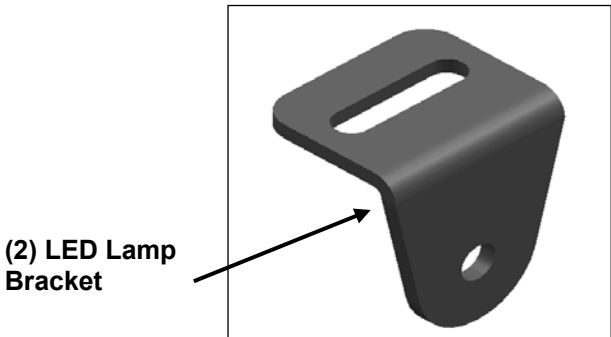
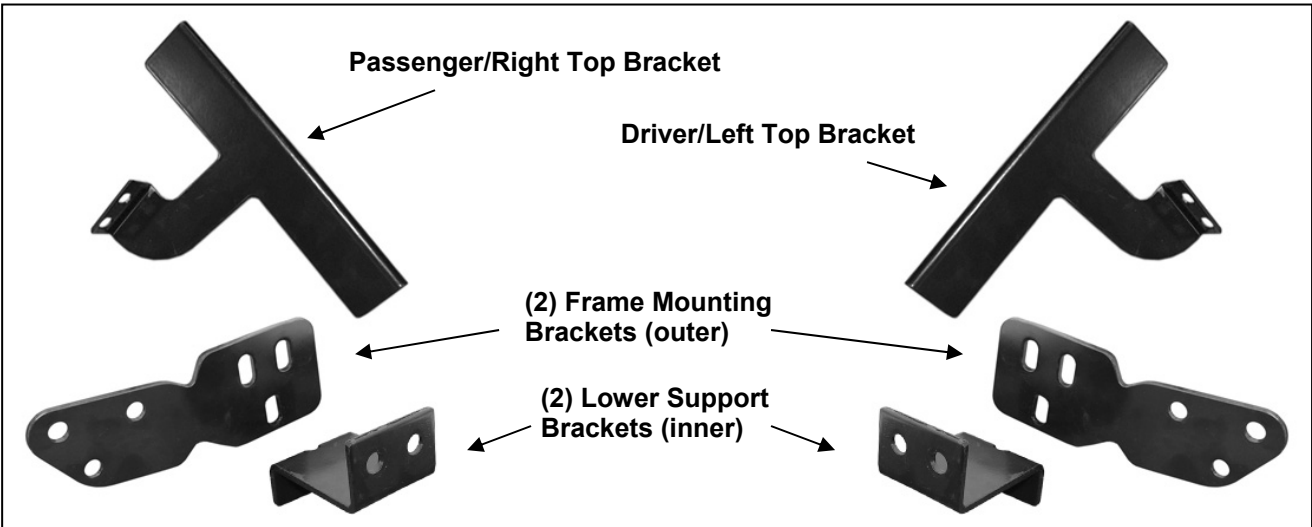

Please Noted:

1. Before you install the Grille Guard on the vehicle, please install the Driver/Left Brush Guard and Passenger/Right Brush Guard on the main body first.
2. Before you install the LED Lamp on the main body please install the LED Lamp Bracket first.
3. If you are not going to install a LED Lamp, the LED Lamp Bracket installation is unnecessary. For main body installation follow the instruction as bellow.

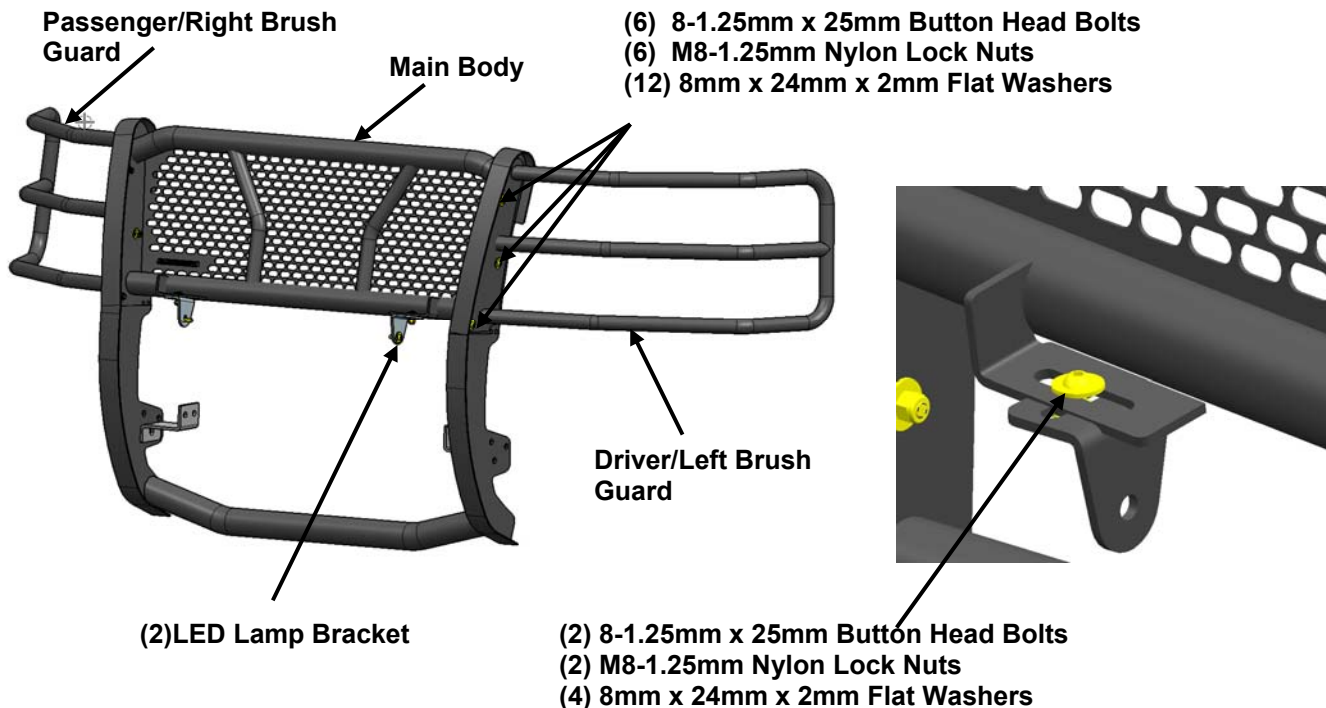

PROCEDURE:

1. REMOVE CONTENTS FROM BOX AND VERIFY ALL PARTS ARE PRESENT. READ INSTRUCTIONS CAREFULLY. DO NOT ATTEMPT INSTALLATION ALONE; PERSONAL INJURY OR DAMAGE TO THE VEHICLE MAY RESULT. CUTTING MAY BE REQUIRED.
2. Start installation from under the passenger side, front of the vehicle. Determine if the vehicle is equipped with or without tow hooks.

On the passenger side, (2) holes will be on the outer wall of the frame rail and (1) on the inner wall, (Figures 3, 4, 6A & 6B).

On the driver side, (2) holes will be on the inner wall of the frame and only (1) on the outer wall, (Figures 7A & 7B).

- a. **Vehicles equipped with tow hooks, (Figure 1):** Remove the hex bolts securing the factory tow hook to the end of the frame. Select (1) Frame Bracket and (1) Lower Support Bracket. Use the factory tow hook bolts to bolt the Brackets to the inside and outside of the frame channel, (Figures 6A, 6B, 7A, 7B). The plastic bumper cover may require minor trimming to clear the Brackets, (Figure 5). Snug but do not tighten hardware at this time.
- b. **Vehicles without openings in bumper cover for tow hooks, (Figure 2):** It will be necessary to cut out openings in the plastic cover to clear the Brackets, (Figure 5). Hold the Frame Bracket up in place and mark the location onto the back of the bumper cover. Remove the bumper cover and place it on a clean, stable work surface. Cut openings for both Frame Brackets. Reinstall bumper cover and proceed to **Step c**.
- c. **Vehicles without tow hooks but with openings in bumper cover, (Figure 1):** Hex bolts have been provided to use in place of the tow hook bolts (refer **Step a**). The plastic bumper cover may require minor trimming to clear the Frame Brackets, (Figure 5). Select

- (1) Frame Bracket and (1) Lower Support Bracket. Insert (1) 12mm x 40mm Hex Bolt with (1) 12mm Flat Washer into the open end of the frame and out the hole in the outside wall of the frame, **(Figures 3, 4, 6A, 6B, 7A, 7B)**. Hold the Frame Bracket over the Hex Bolt and secure it with a 12mm Flat Washer, 12mm Lock Washer and 12mm Hex Nut. Line up the remaining mounting holes in the Frame and Support Bracket with the (2) remaining holes in the frame channel. Snug hardware but do not tighten at this time.
3. Repeat appropriate **Step 2** for driver side Frame and Support Bracket installation
 4. Line up the lower hole in the passenger side Frame Bracket and the Support Bracket and bolt together with (1) 12mm x 40mm Hex Bolt, (2) 12mm Flat Washers, (1) 12mm Lock Washer and (1) 12mm Hex Nut, **(Figures 6A, 6B, 7A, 7B)**. Repeat this Step for driver side Frame Bracket. Snug but do not tighten hardware at this time.
 5. Next, open the hood and remove the plastic cover between the top of the grille and the radiator. **NOTE:** Use a small flat head screwdriver to remove the plastic clips. **IMPORTANT:** Do not damage the clips holding the grille in place. Use a pair of “needle nose” pliers to carefully squeeze the back of the clips to release and gently pull the grill forward, **(Figure 8)**. Once all of the clips released and the two outer bolts have been removed, carefully remove the grille by pulling it forward from the vehicle. **IMPORTANT:** Make sure all clips have been released before attempting to remove grille.
 6. Select both Top Brackets. Apply a layer of Adhesive Backed Foam Tape to the bottom of the Brackets to protect the bumper from contact with the Top Brackets, **(Figures 9 & 10)**.
 7. Loosen the top bumper bracket bolt and remove the (2) bumper bolts behind the bumper, **(Figure 9)**. Select the passenger side Top Bracket. Slide the Top Bracket down between the bumper and the top bumper bracket. It may be necessary to loosen the bumper bracket bolts to move the top bumper bracket back. Line up the (2) holes in the Top Bracket with the top bumper bracket and bolt in place with the factory hex bolts, **(Figures 9 & 10)**. Tighten the top bumper bolt only at this time. Repeat this Step to install the driver side Top Bracket. **IMPORTANT:** Only install one Top Bracket at a time. It is not necessary to completely loosen the front bumper.
 8. With assistance, hold the Grille Guard up in position on the outside of the Mounting Brackets. Bolt the Grille Guard to the Frame Brackets with (6) 12mm x 35mm Hex Bolts, (12) 12mm Flat Washers, (6) 12mm Lock Washers and (6) 12mm Hex Nuts, **(Figures 6B, 7B & 11)**. Snug but do not tighten hardware at this time.
 9. Line up the passenger side Top Bracket with the (2) holes in the upright on the Grille Guard. Bolt the Top Bracket to the upright with (2) 8mm Button Head Bolts, (4) 8mm Flat Washers, (2) 8mm Lock Washers and (2) 8mm Hex Nuts, **(Figure 11)**. Do not tighten hardware at this time. Repeat this Step for driver side Top Bracket installation.
 10. Level and adjust the Grille Guard. Proceed to tighten all hardware. Once all mounting bolts are tight, reinstall the factory grille shell, line up the clips and gently push it into place. Reinstall the top plastic cover.
 11. Do periodic inspections to the installation to make sure that all hardware is secure and tight.

To protect your investment, wax this product after installing. Regular waxing is recommended to add a protective layer over the finish. Do not use any type of polish or wax that may contain abrasives that could damage the finish.

For stainless steel: Aluminum polish may be used to polish small scratches and scuffs on the finish. Mild soap may be used also to clean the Grille Guard.

For gloss black finishes: Mild soap may be used to clean the Grille Guard.

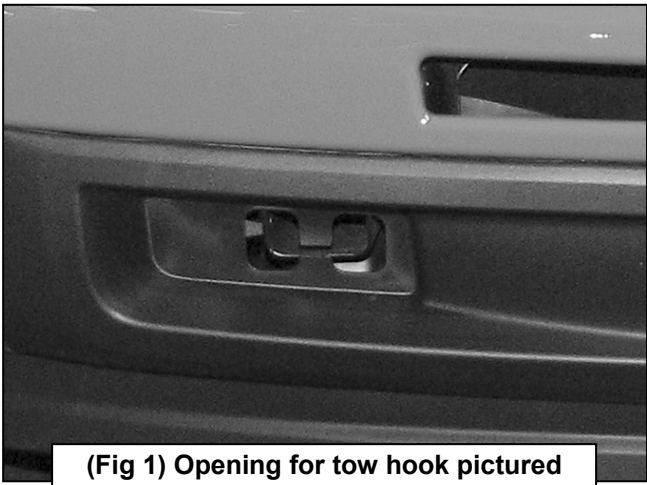

(Fig 1) Opening for tow hook pictured



(Fig 2) No opening in bumper cover

- (1) 12mm x 40mm Hex Bolt
- (1) 12mm Flat Washer

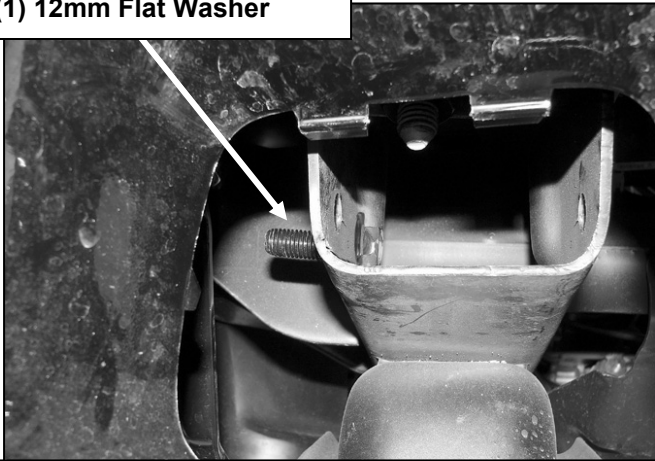

(Fig 3) Passenger side frame channel pictured

- (1) 12mm x 40mm Hex Bolt
- (1) 12mm Flat Washer



(Fig 4) Passenger side Mounting Bracket pictured

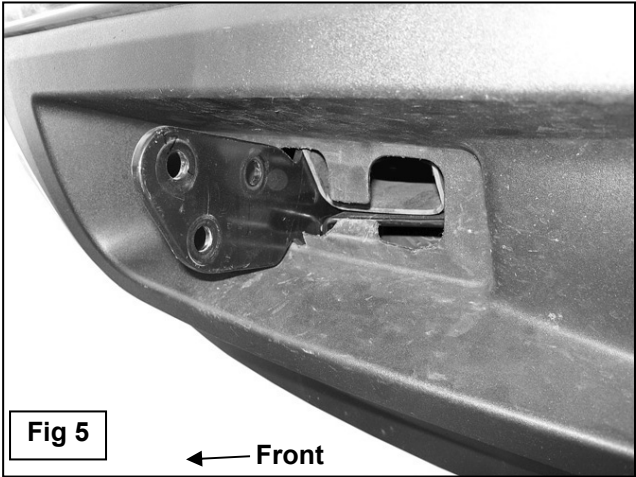
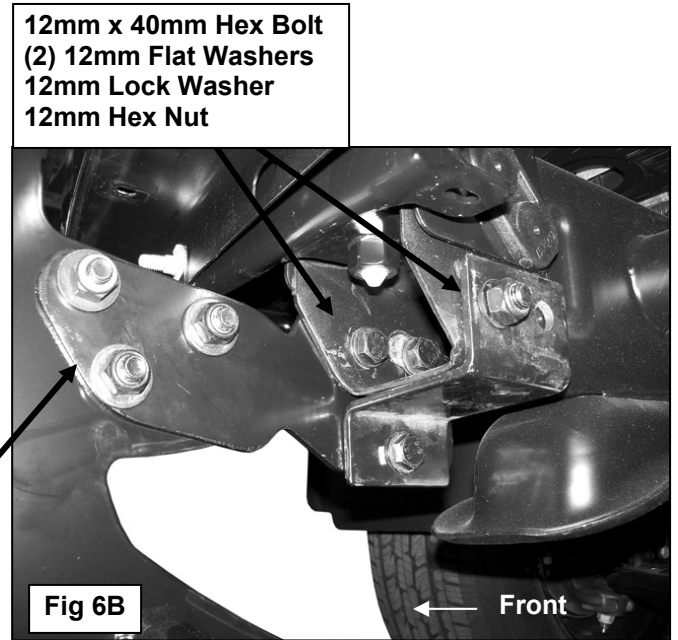
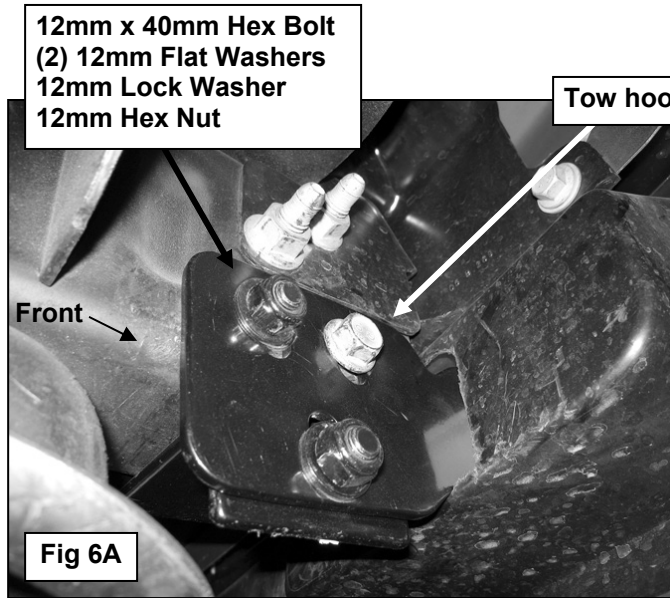

Fig 5

← Front

Passenger Side Mounting Bracket Installation Pictured (Bumper cover removed for instruction purposes)



- (3) 12mm x 35mm Hex Bolts
- (6) 12mm Flat Washers
- (3) 12mm Lock Washers
- (3) 12mm Hex Nuts

Driver Side Mounting Bracket Installation Pictured

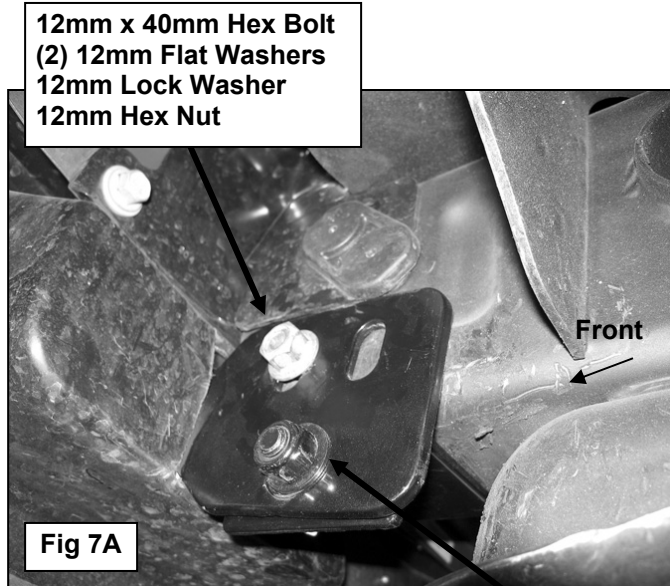

- 12mm x 40mm Hex Bolt
- (2) 12mm Flat Washers
- 12mm Lock Washer
- 12mm Hex Nut

- (3) 12mm x 35mm Hex Bolts
- (6) 12mm Flat Washers
- (3) 12mm Lock Washers
- (3) 12mm Hex Nuts

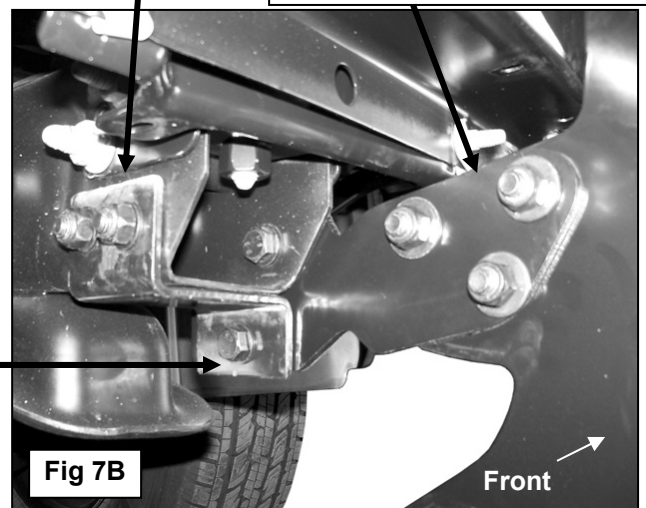

Passenger Side Mounting Bracket Installation Pictured

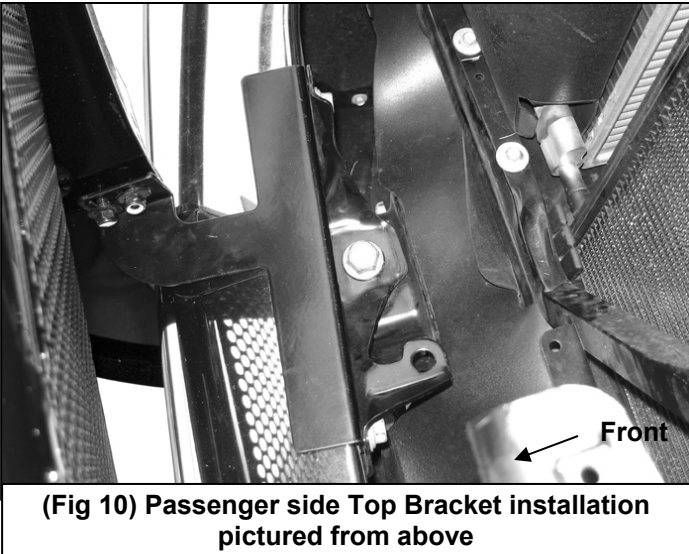
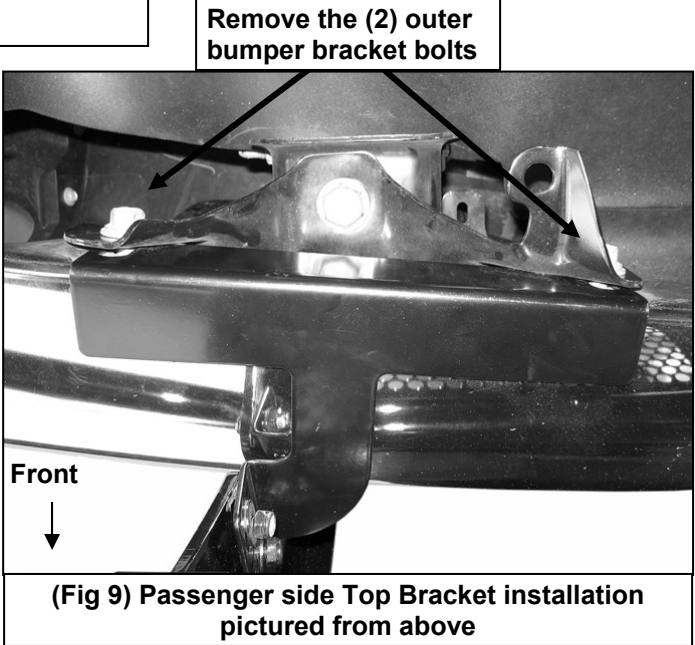
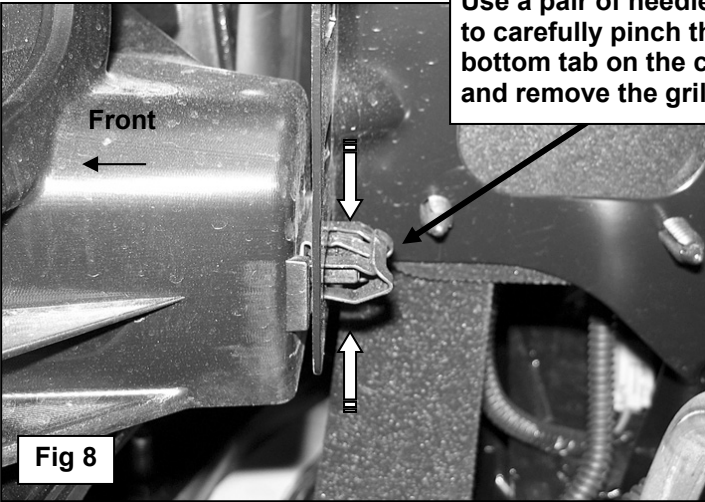

- (2) 8mm x 25mm Button Head Bolts
- (4) 8mm Flat Washers
- (2) 8mm Lock Washers
- (2) 8mm Hex Nuts

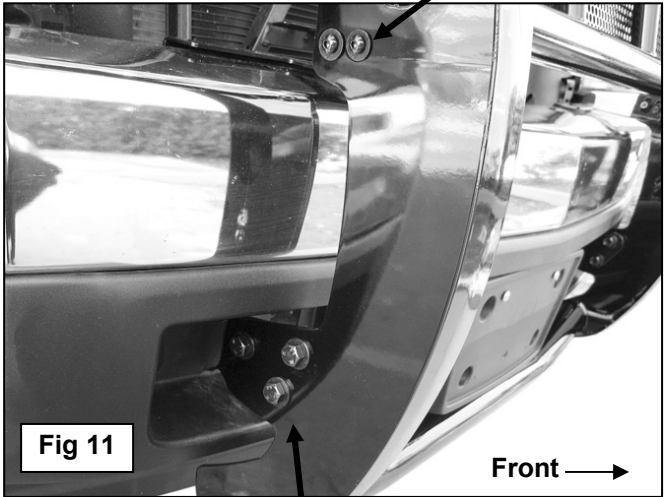

- (3) 12mm x 35mm Hex Bolts
- (6) 12mm Flat Washers
- (3) 12mm Lock Washers
- (3) 12mm Hex Nuts

