



HFB-11-001

Off-Road Jack Mount Ford Bronco Tailgate

HFB-11-001

Rev. 0. 11/22

Components and Hardware:

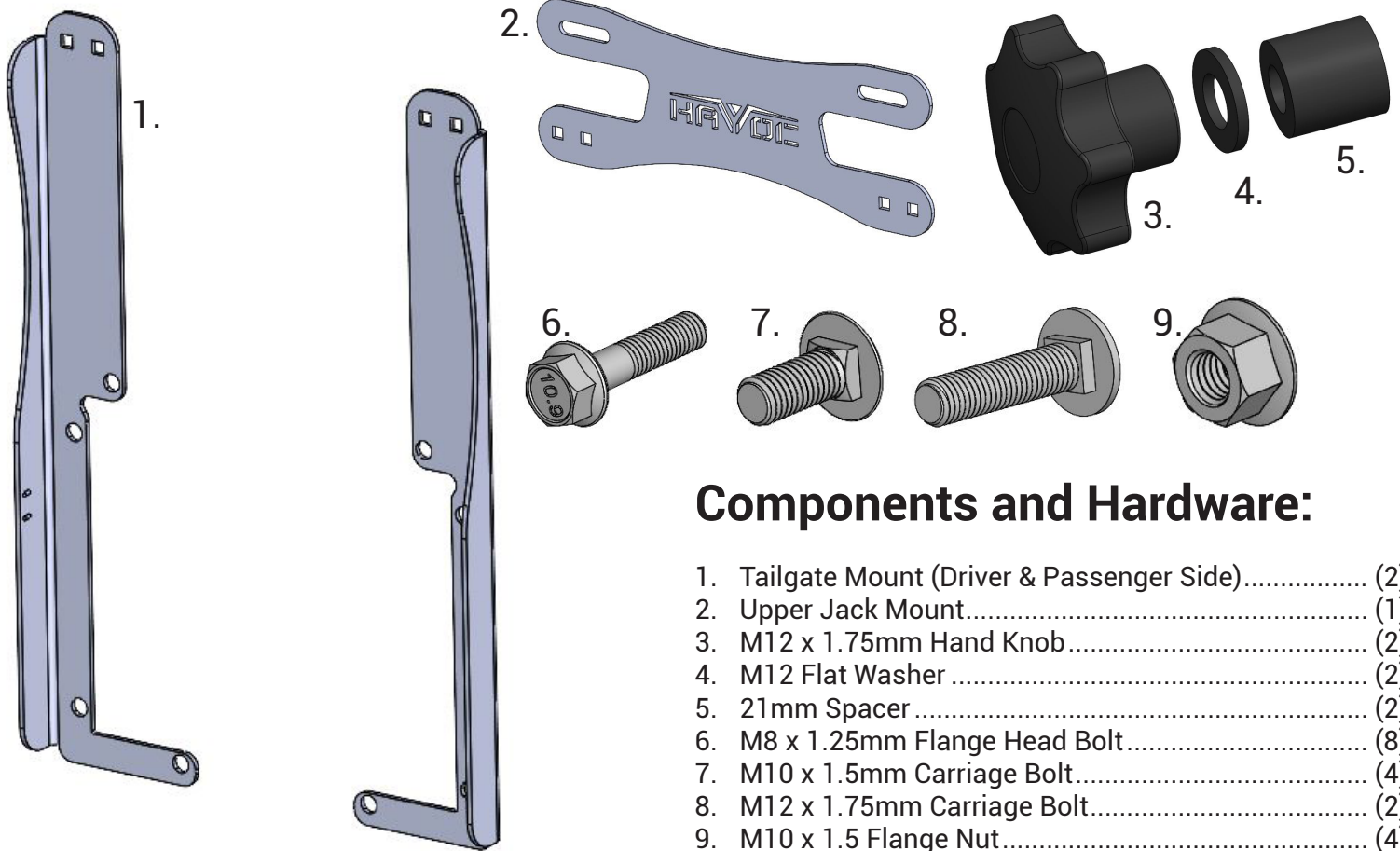

Components and Hardware:

- 1. Tailgate Mount (Driver & Passenger Side)..... (2)
- 2. Upper Jack Mount..... (1)
- 3. M12 x 1.75mm Hand Knob..... (2)
- 4. M12 Flat Washer (2)
- 5. 21mm Spacer (2)
- 6. M8 x 1.25mm Flange Head Bolt..... (8)
- 7. M10 x 1.5mm Carriage Bolt..... (4)
- 8. M12 x 1.75mm Carriage Bolt..... (2)
- 9. M10 x 1.5 Flange Nut..... (4)

Step 1:
Remove spare tire from tailgate tire mount.

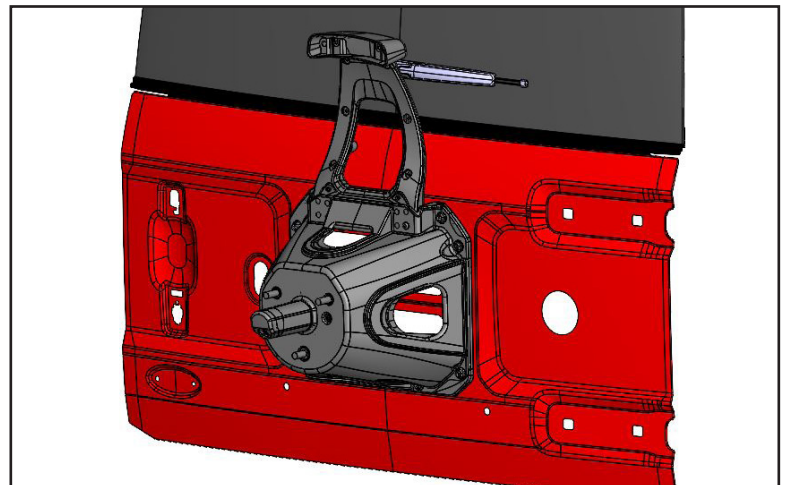

Off-Road Jack Mount, Bronco

Step 2:

Remove the spare tire mount from the Bronco tailgate. The spare tire mount is attached with 8 bolts.

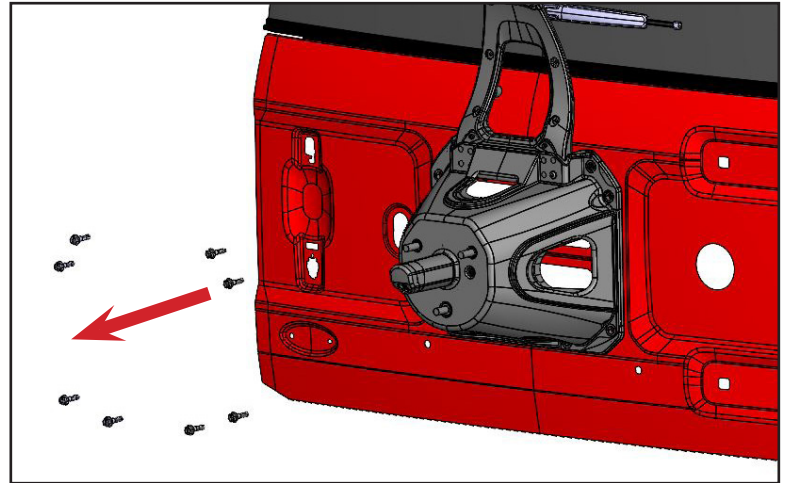

Step 3:

Attach the two Havoc jack mounts (1) to the tailgate with the OE spare tire mount removed in step 2. Use the provided eight M8 Flange Bolts (6) and thread into the tailgate.

Avoid using power tools or air tools. Over tightening could damage the threaded inserts in the tailgate. Tighten to 20ft lbs torque to secure.

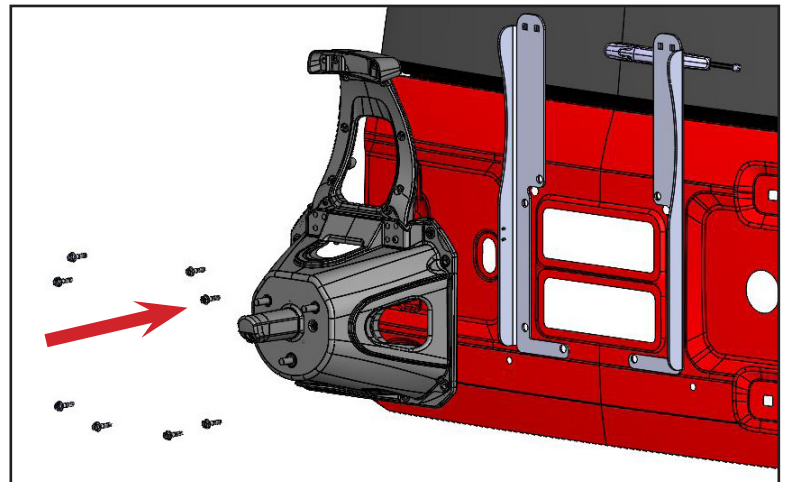

Step 4:

Attach the upper jack mount (2) to the tailgate mounts (1). Use the M10 Carriage bolts (7) and M10 flange nuts (9).

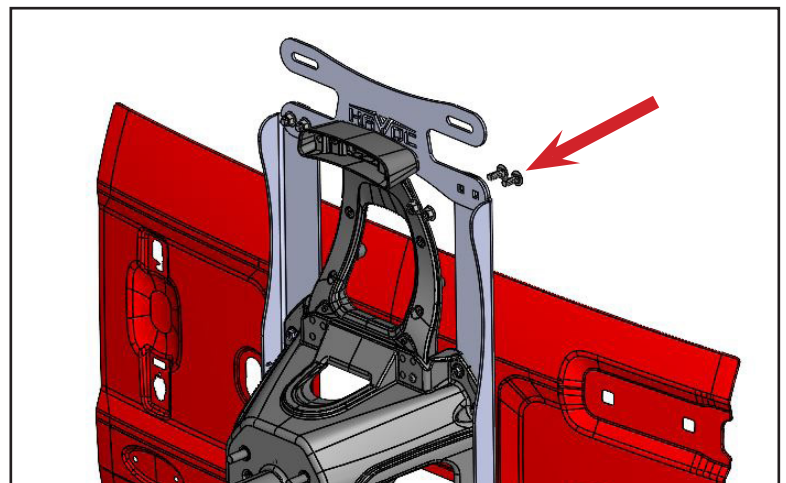

Off-Road Jack Mount, Bronco

Step 5:

Mount the offroad jack to the Havoc mount. Use the M12 carriage bolt (8) through the offroad jack, then through nylon spacer (5) to slots in upper jack mount (2). Use flat washer (4) and secure with M12 hand knob (7).

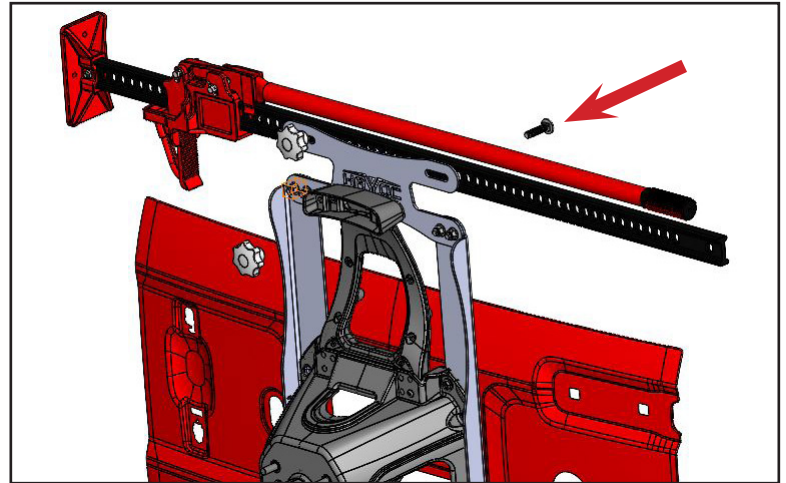

Step 6:

Lastly, mount spare tire to OE tire mount.

