

APPLICATION

MODEL YEAR

AMP PART#

Ford Super Duty - Crew Cab

2022 - 2026

77242-01A

Note: Only compatible on Crew Cab models and only compatible with SYNC 4 Vehicles Trim levels include: Lariat, King Ranch, Platinum & Limited Models.

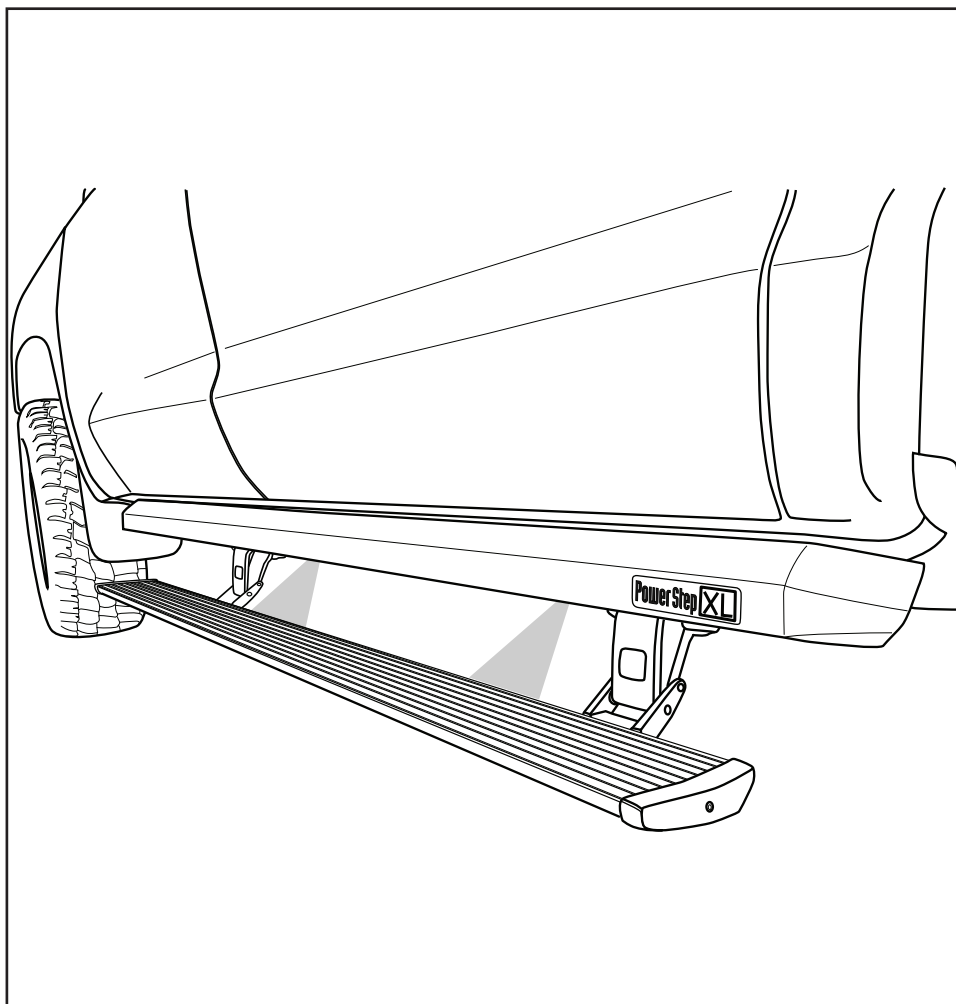

INSTALLATION TIME

3-5 Hours

Professional installation recommended

SKILL LEVEL



4= Experienced

TOOLS REQUIRED

- Safety goggles
- Measuring tape
- 8 mm socket
- 10 mm socket
- 13 mm socket
- 1/2" socket
- Ratchet wrench and extension
- Wire crimpers
- Wire stripper / cutter
- 3/16" hex key wrench (allen wrench)
- 4mm hex key wrench (allen wrench)
- Electrical tape
- Weather proof caulking (silicone sealer)
- Silicone spray
- Drill
- Heat Gun

WARRANTY

5-Year Limited Warranty

REALTRUCK TECH SUPPORT 1-888-983-2204 (Press 2) Monday - Friday, 8:00 AM - 5:00 PM EST

Designed and manufactured by RealTruck AMP Research® • Made in Mexico
 Patent Protected. Please see our product site for applicable patents. www.realtruck.com/b/amp-research/
 © RealTruck Group, Inc., 2025 • Five-year limited warranty. • Professional installation is recommended.

INSTALLATION GUIDE

Attaching motor to Linkage assembly.

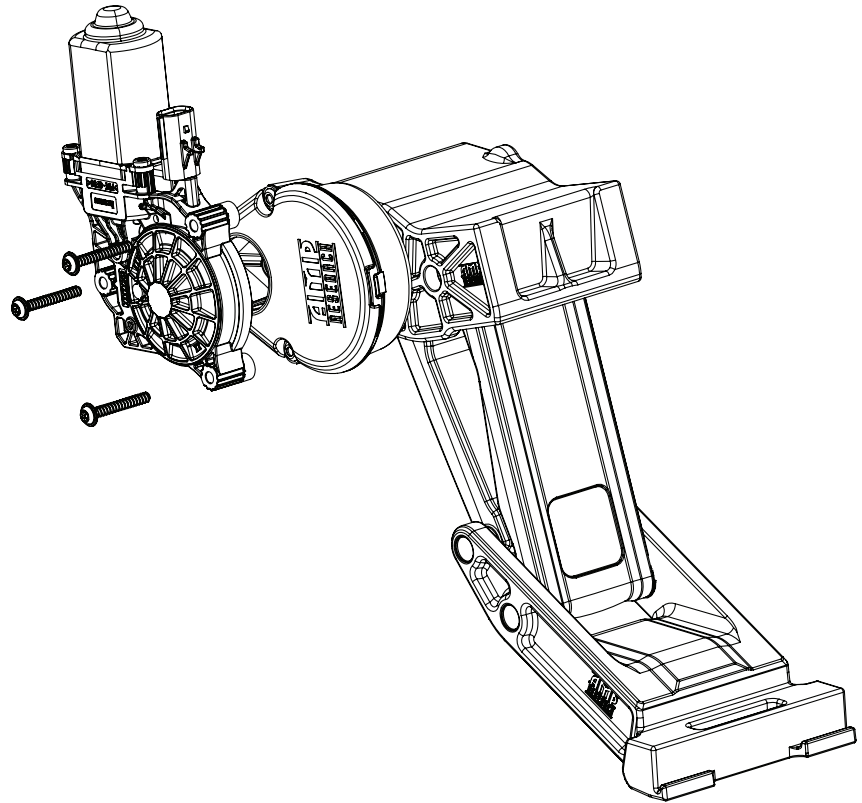

EXPLODED VIEW

Motor Linkage

Motor Kit

Delta PT screws

CAUTION: HANDLE WITH CARE.

To ensure our customers receive all components with full integrity, we pack the motors separate from their linkage assemblies. This requires that the installer position and fasten the motor before continuing with the install. Please follow the instructions below and handle the assembly carefully.

CAUTION: Dropping the assembly or any excessive impact MAY cause damage to the motor.

Instructions:

1. Position the gear cover in place as shown if not already in place.
2. Seat motor into position on the three mounting bosses. This may require an adjustment of the gear by moving the swing arms.
3. After seating into place, fasten the motor with the three motor mount screws with 4mm Hex Head. Tighten screws to 36 in-lbs (4N-m). **Do not over torque.**

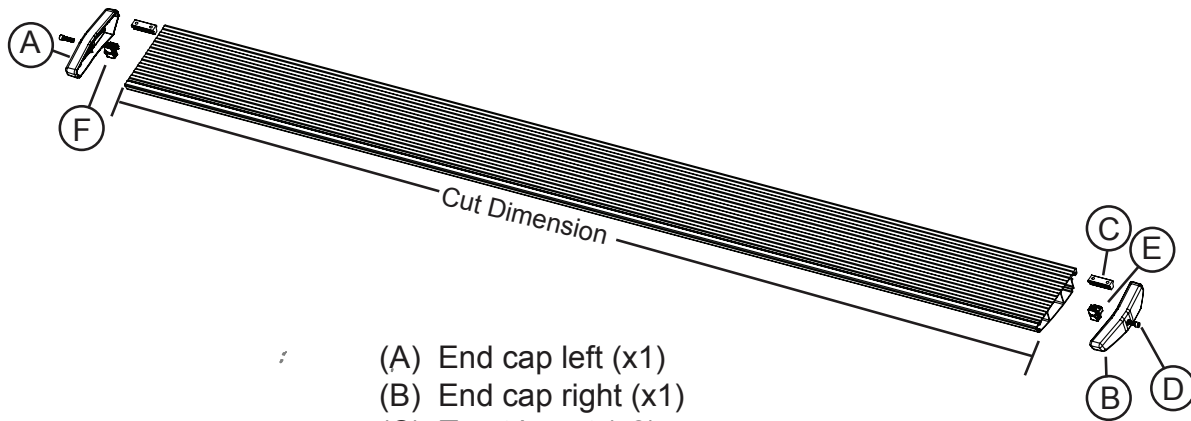

- (A) End cap left (x1)
- (B) End cap right (x1)
- (C) T-nut insert (x2)
- (D) Socket cap screw (x2)
- (E) End cap wedge right (x1)
- (F) End cap wedge left (x1)

1 x2

Running board assembly

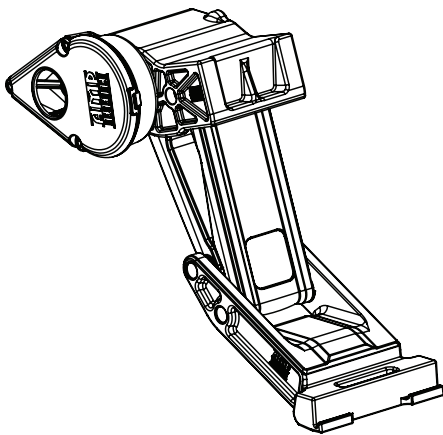

2 x2

Motor Linkage assembly

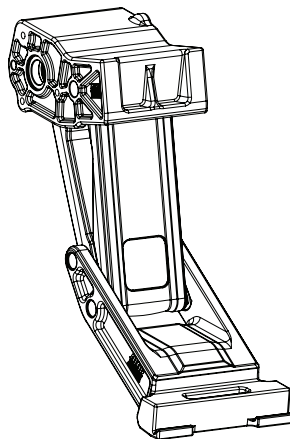

3 x2

Idler Linkage assembly

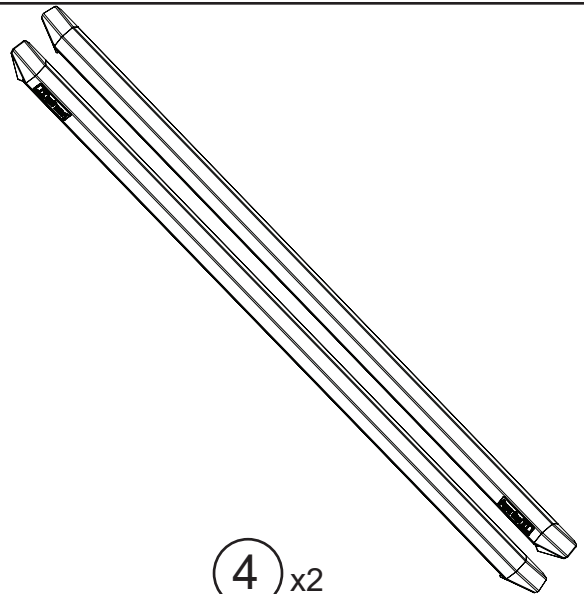

4 x2

Rail Assembly

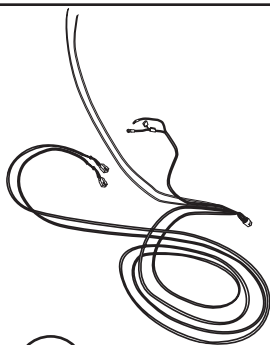

5

Wire harness

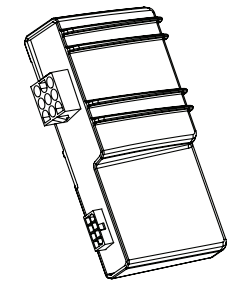

6

Controller STA



7 x2

Posi-Lock™ (Grey)

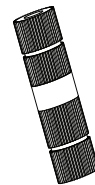

8 x2

Posi-Tap™ (Pink)

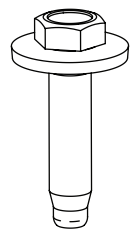

9 x8

M8 Hex Bolt w/
Conical washer

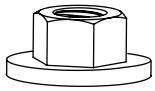

10 x16
M8 Nut w Conical washer

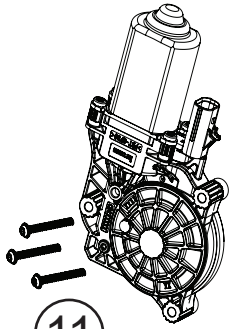

11 x2
Motor Kit



12 x6
M5 Washer



13 x4
M6 Flange Bolt

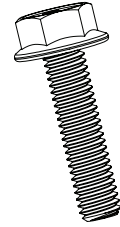

14 x6
5/16 Flange Bolt



15 x8
Socket Cap Screw

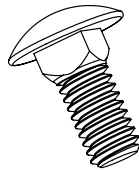

16 x14
5/16-18 Carriage Bolt

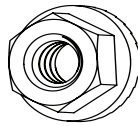

17 x20
5/16-18 Flange nut

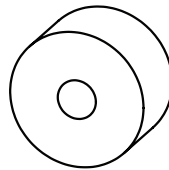

18 x4
Upper Mount Spacer

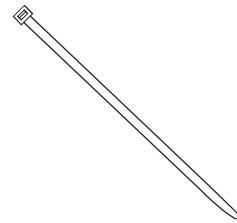

19 x20
Cable tie (7'')

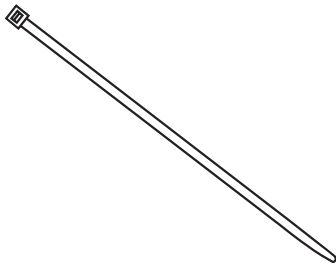

20 x2
Cable tie (11'')

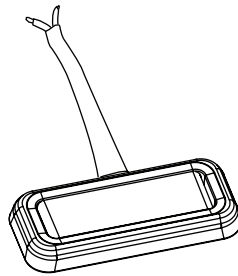

21 x4
LED Lamp

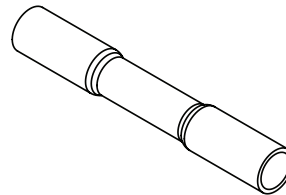

22 x8
Butt Connector

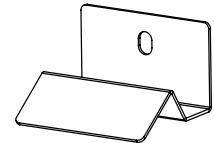

23 x4
LED Light Bracket

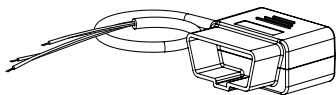

24
OBD II Plug

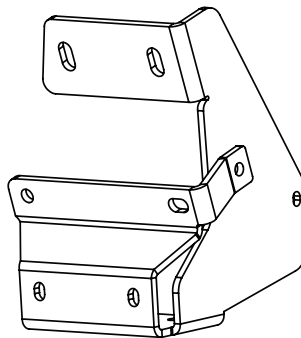

25 x4
Linkage Mounting Bracket

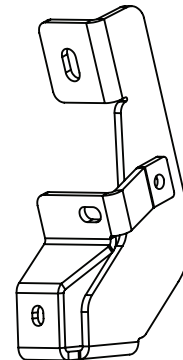

26 x2
Rail Mounting Bracket

Insert 7 Carriage bolts (16) into slot on rail (4). Insert from either end of rail. Add 2 Light Brackets (23) on the 3rd and 5th bolt. Insert Flange nut (17) onto bracket tab to attach light brackets into position shown. Leave loose to allow for adjustment.

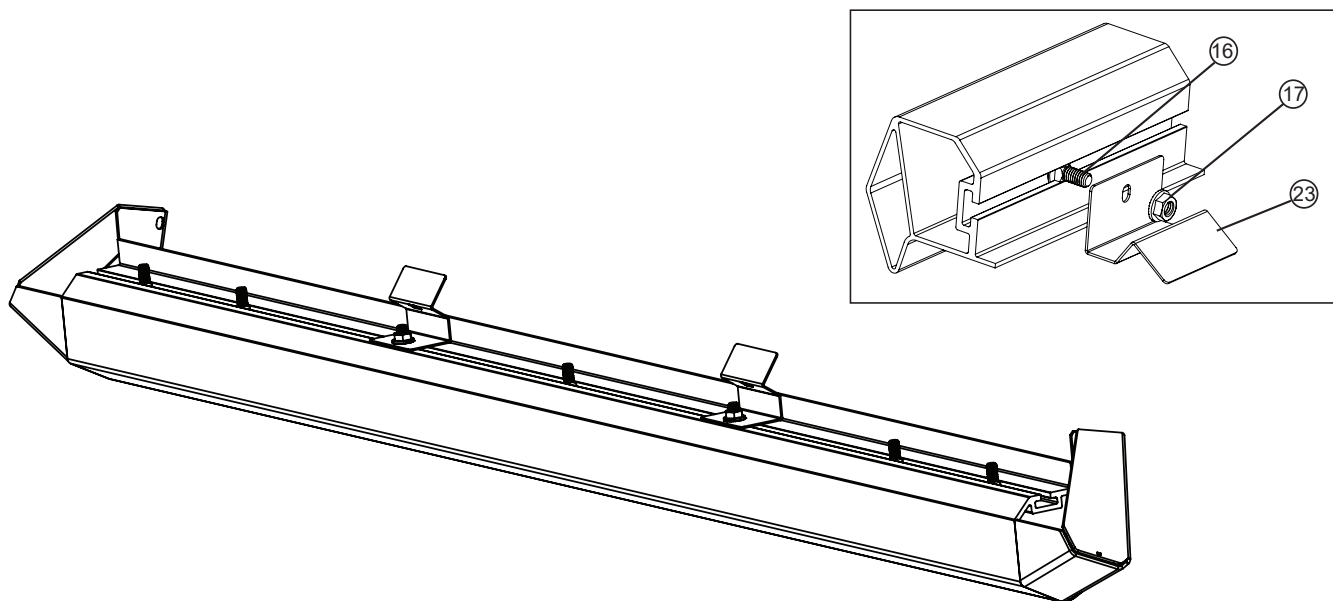

1

Using Flange Nuts (17), assemble Brackets 2x (25) & 1x (26) onto the rail (4), using the carriage bolts (16) left from previous step. Next, install Flange Bolt (14) and Flange Nut (17) onto bracket tab. Driver side shown. Dimensions shown are for reference.

Do not tighten this will allow for rail adjustment when mounted onto vehicle.

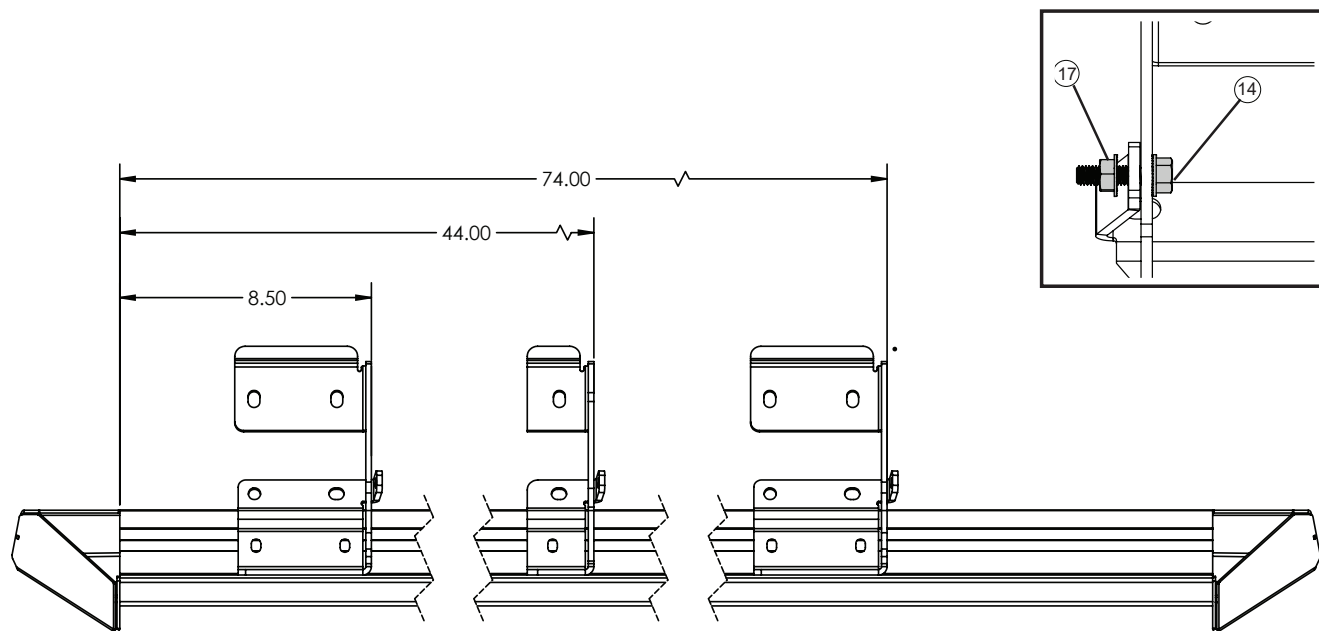

Note: Badge on rail sits towards the rear of the vehicle!

2

Set rail up into position. Starting with the rear bracket work towards the two front brackets. Slide Brackets over captive studs and use provided Nuts 8x (10). Snug to body and torque to 16 ft-lbs.

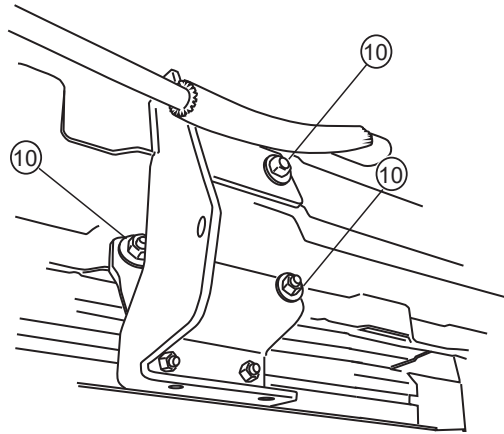

3

Start from rear of vehicle and Torque 5x Flange Nuts (17) to 16 ft-lbs.

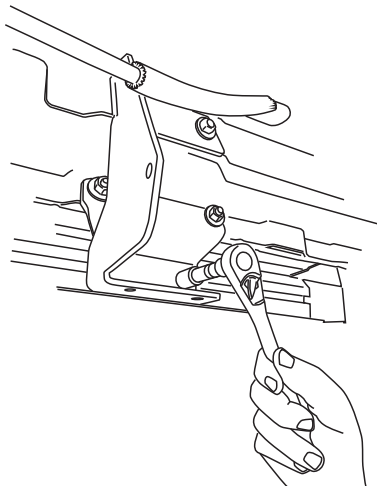

4

Thread supplied bolts 2x (9) into Front Drive Linkage. Repeat step for Rear Idler Linkage. Do not tighten.

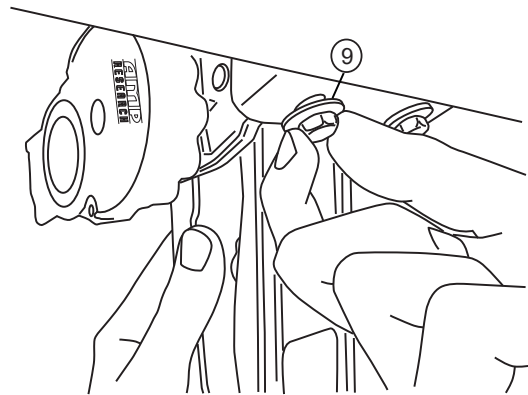

5

Install provided spacer (18) and M6 bolt (13) into upper mount as shown on both the Drive and Idler linkages. Do not tighten.

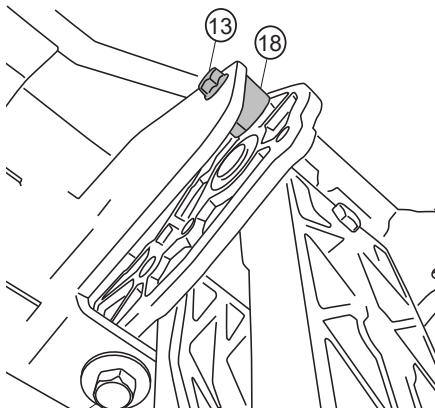

6

Slide mounting T-nut into position, Center board in rail pocket. Tighten fasteners to 10 ft-lbs.

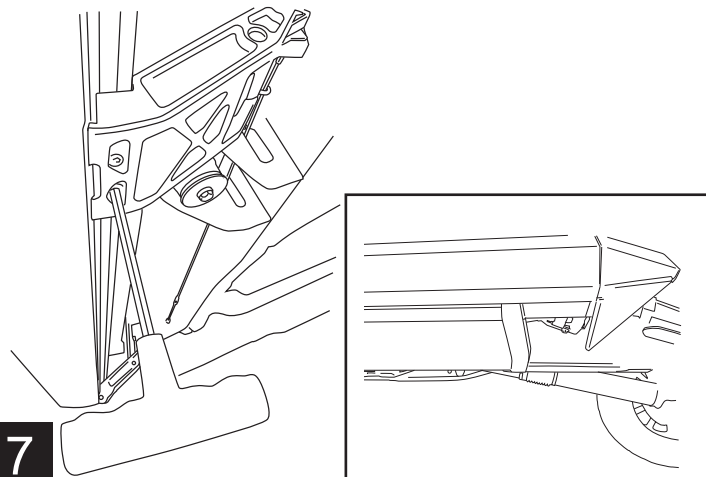

7

Using a 13mm socket Torque linkage bolts 4x (9) to 16 ft-lbs Next use a 10mm socket, torque linkage spacer bolt 2x (13) from step 6 to 8 ft-lbs. Once linkage (13) are tight cycle board to verify steps deploy under own weight.

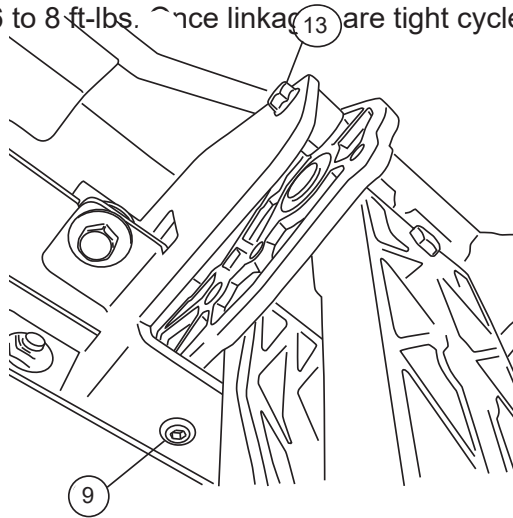

8

Attach motor to harness. Using a 4mm hex Torque to 36 in-Lbs.

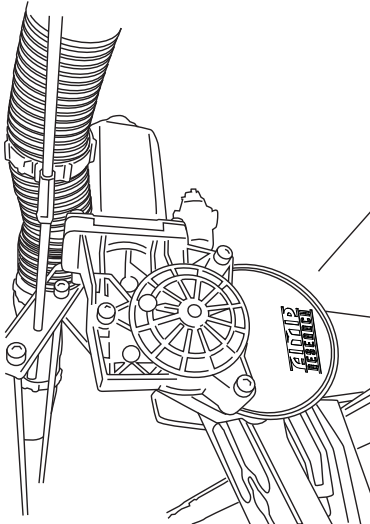

9

Torque bolts on mounting brackets to 16ft-lbs.

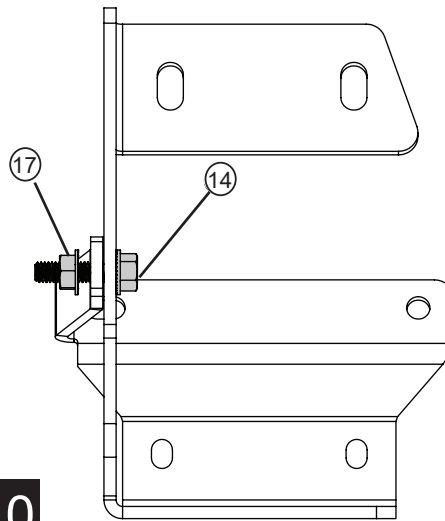

10

Remove fuse from wire harness

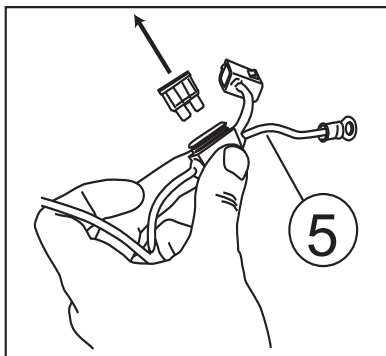

11

Attach wire harness to controller (make sure connector locking tabs fully engage). Mount controller with the two 11" tie wraps (20) to factory conduit, just forward of battery.

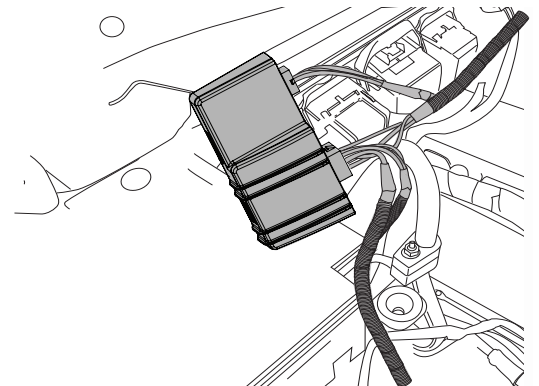

12

Connect red and black power leads to battery. Red lead goes to positive. Route shorter leg of harness down passenger-side wheel well and longer leg of harness down along driver side wheel well.

Secure with tie wraps.

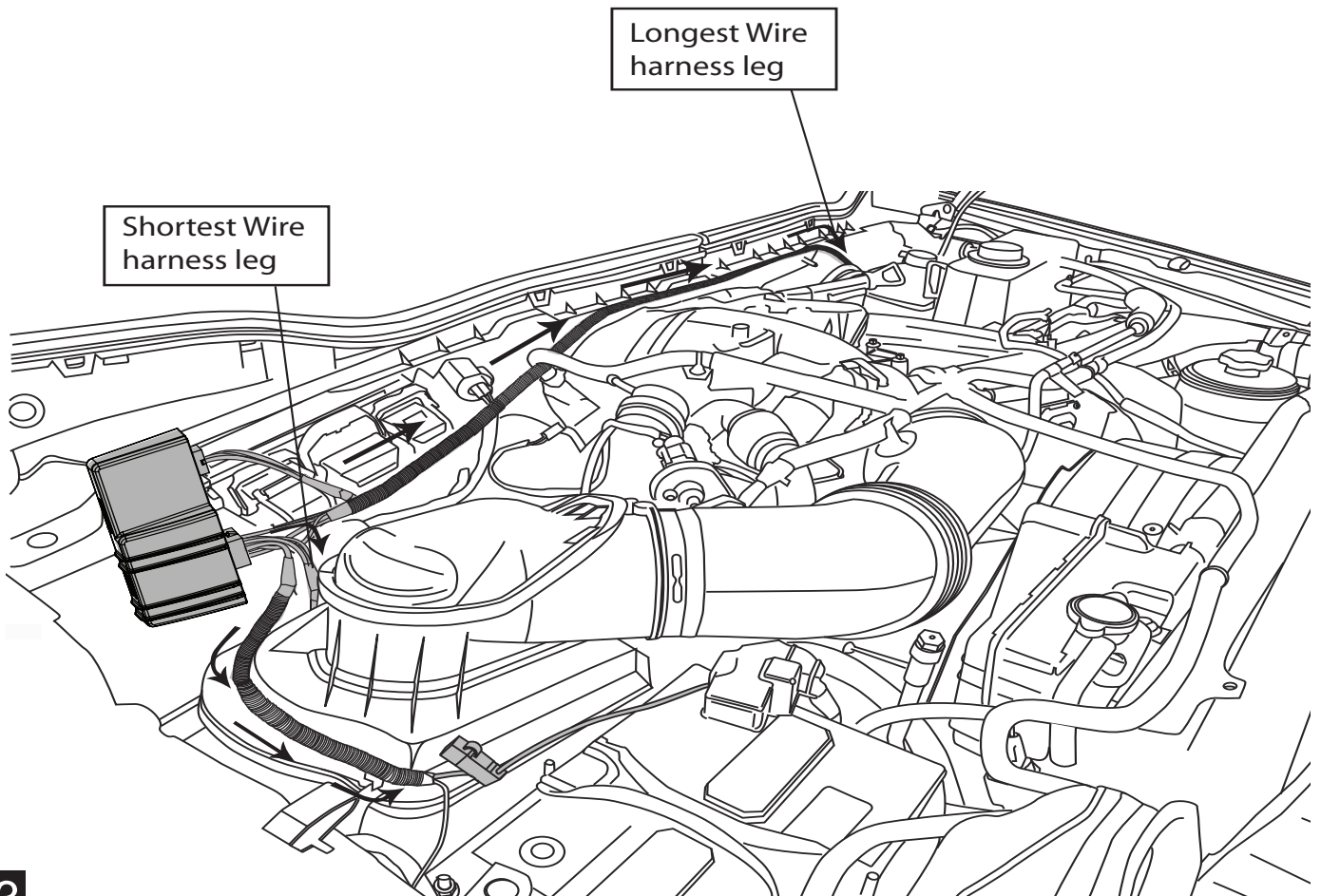

13

Remove driver side front kick panel and door sill plate. Roll back carpet to access hole for passing trigger wires into cab of vehicle.

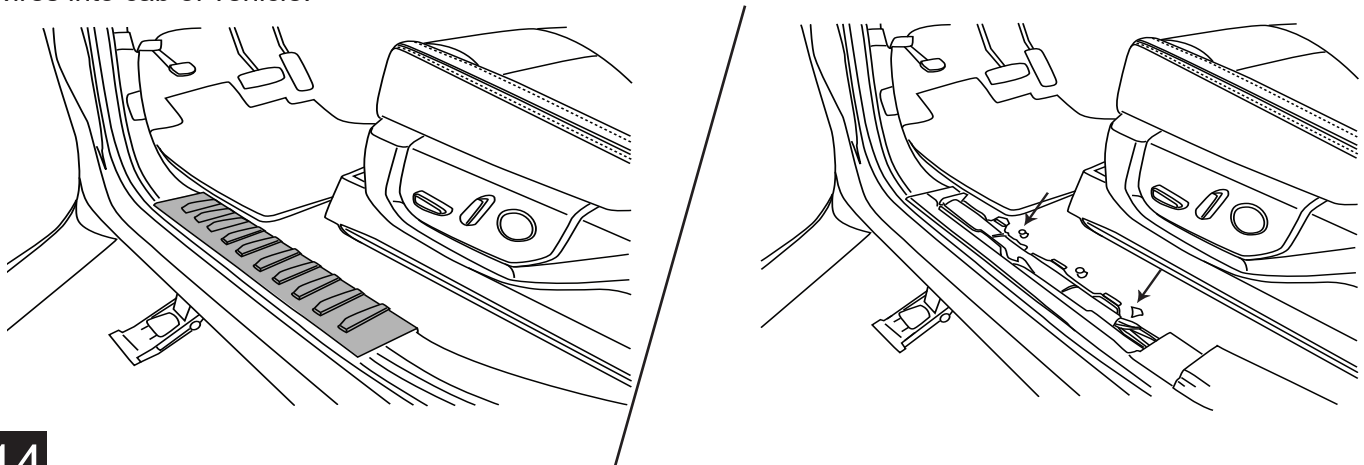

14

Remove grommet in floor panel above front linkage on driver side. Poke small hole into grommet and thread the two trigger wires through and up into the cabin of vehicle. Seal grommet with silicone sealer.

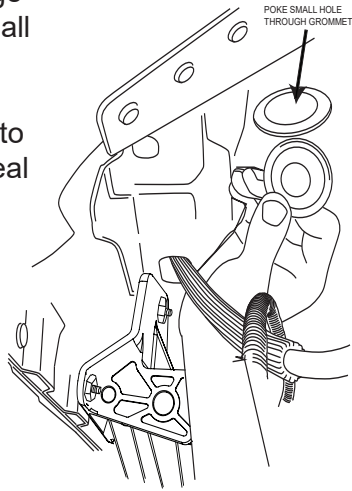

15

Connect harness to motor. Secure harness with tie wraps (19).

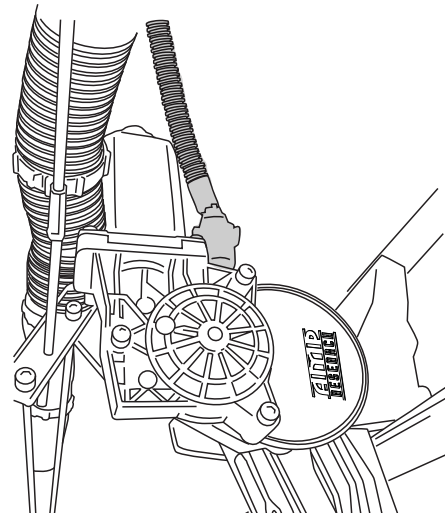

16

Affix LED lamp (21) to LED Bracket (23) as shown. Slide bracket into desired position and tighten using 5/32" Allen key.

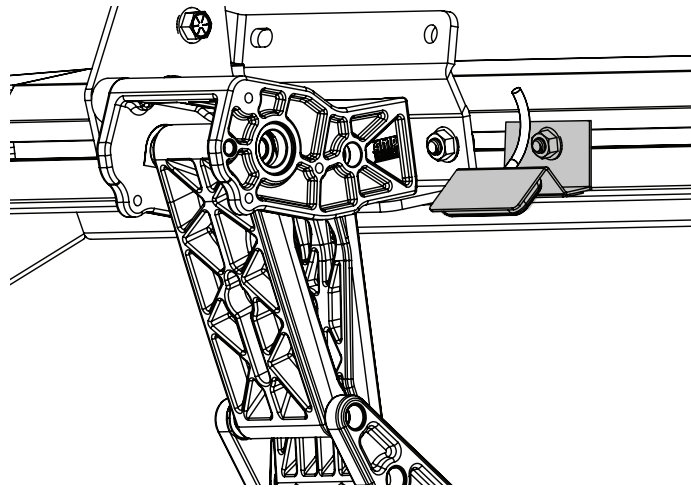
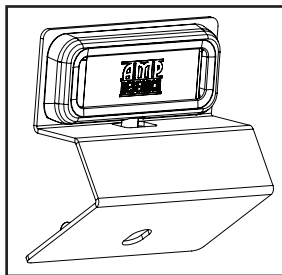

17

Using supplied butt connectors (22), connect the lamp wires. Red to Red, Black to Black. Once Crimped use heat gun to shrink tube. Close and wrap conduit with electrical tape. Secure all loose wires with cable ties. Pull lamp wires upward to avoid any wire snagging.

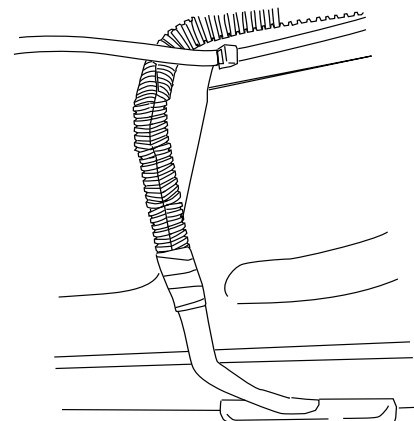
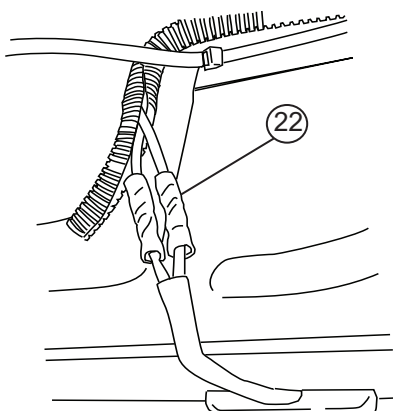

18

Locate black module just above e-brake pedal, and proceed to remove it for easier access. To remove module from bracket, push tab as shown and slide bracket downward.

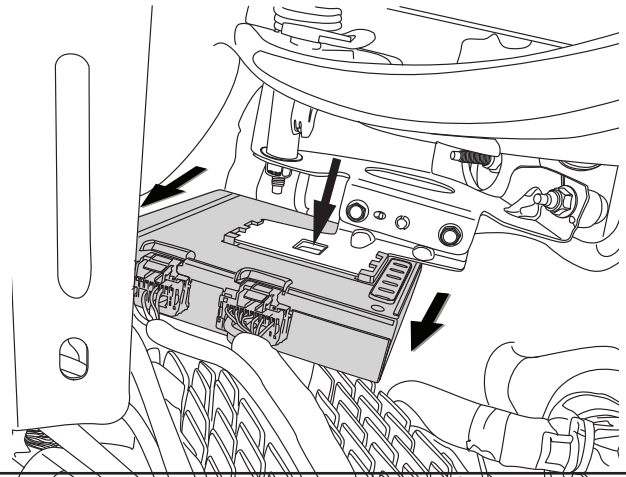

19

Locate the following wires (black connector) and connect the blue and white wires of the Powerstep Connection Module with supplied Posi-Tap™ (8) to the following wire colors listed below.

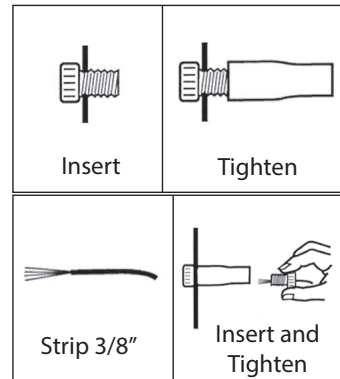
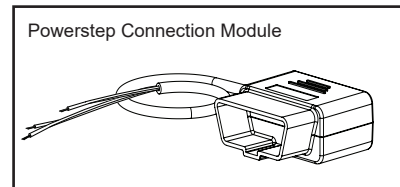

Factory Can Wire	Powerstep Connection Module wire color
Green w/blue stripe	White
White w/green stripe	Blue

20 After connecting wires, slide module back on to bracket, and ensure locking tab engages.

Use supplied Posi-Lock™ (7) to attach the 2 purple wires of the OBD harness to the main harness. Attach matching colors on the harness to the wires on the module. Lastly reinstall Factory OBD port removed in step 20. Plug in module to OBD port on the vehicle. Reinstall sill plate removed from step 15.

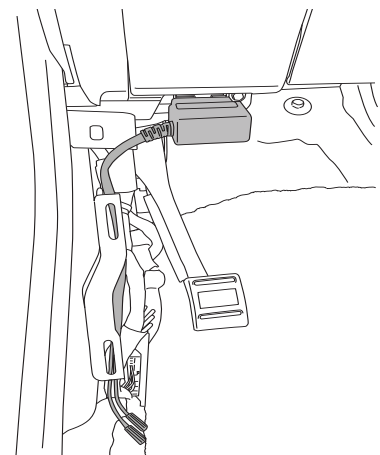
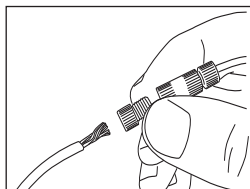

21

OBD II install: Use Supplied Posi-Lock™ connectors to attach the Plug and Play Module to the Harness. Attach matching colors on the harness to the wires on the module. Plug in module to OBD II port on the vehicle. Secure harness with supplied tie wraps. **Note: If the OBD II pass thru harness (76404-01A) was purchased see install sheet supplied in packaging. The pass through harness allows for an open port for other accessories. See below for a brief description.**

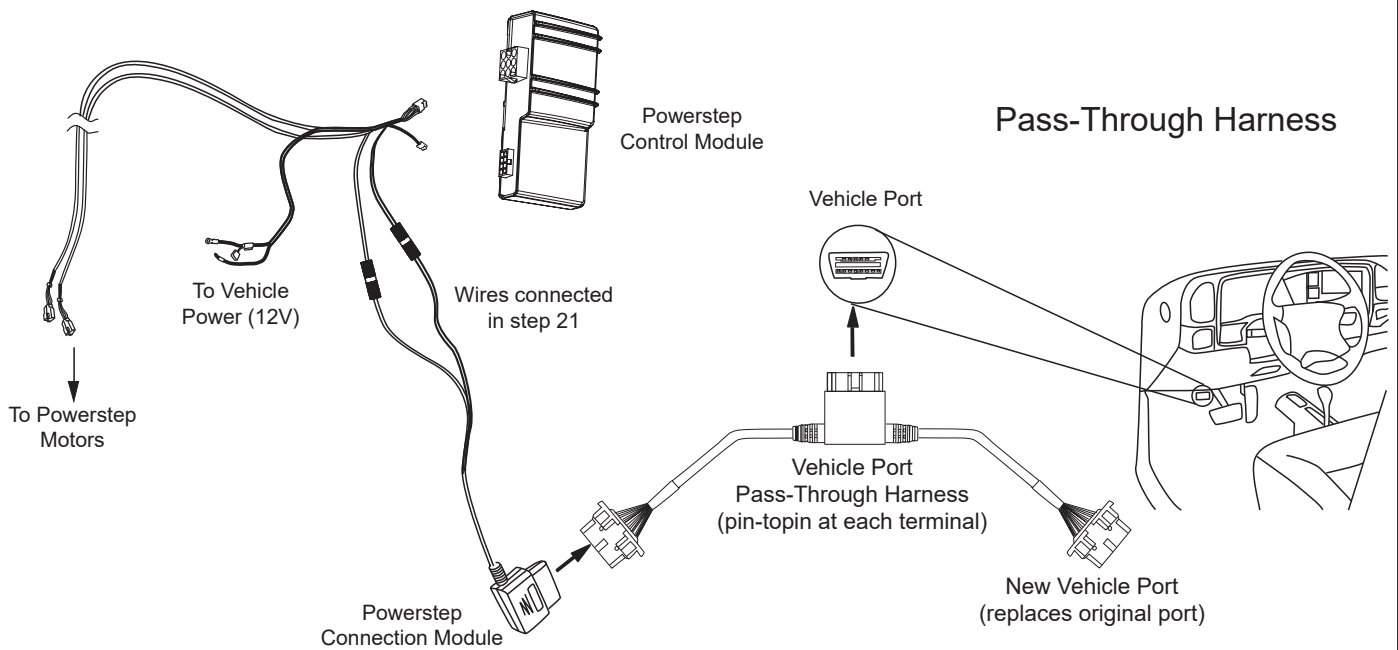
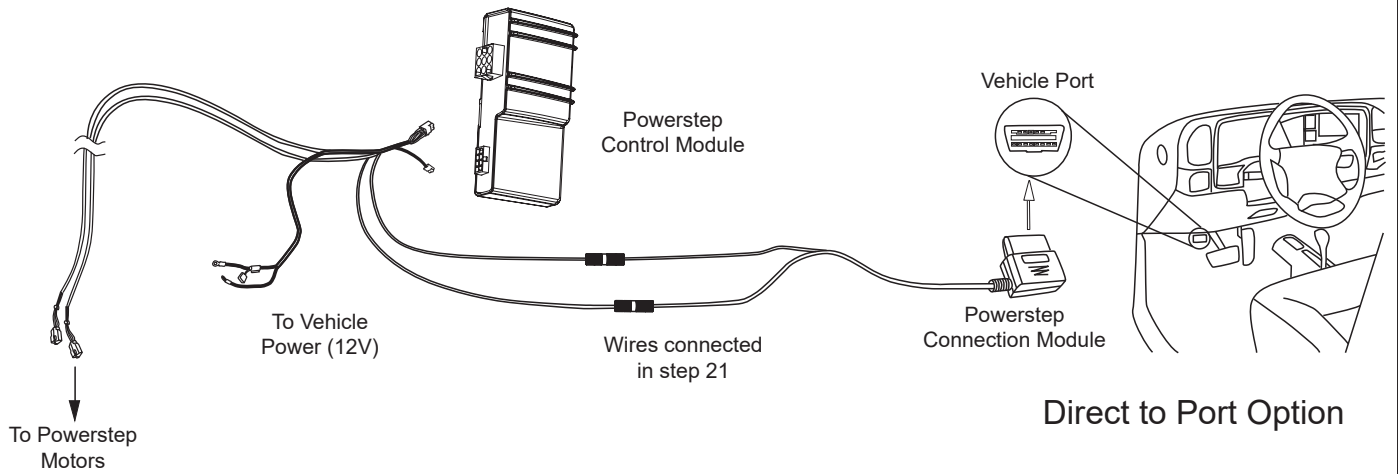

Replace fuse.

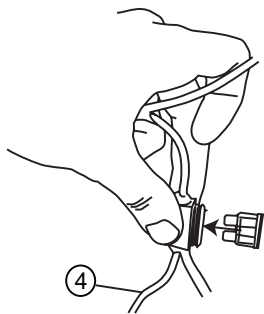

Check that all doors activate the Power Step and the LED Lights work when doors open and close. Reinstall any remaining trim panels.

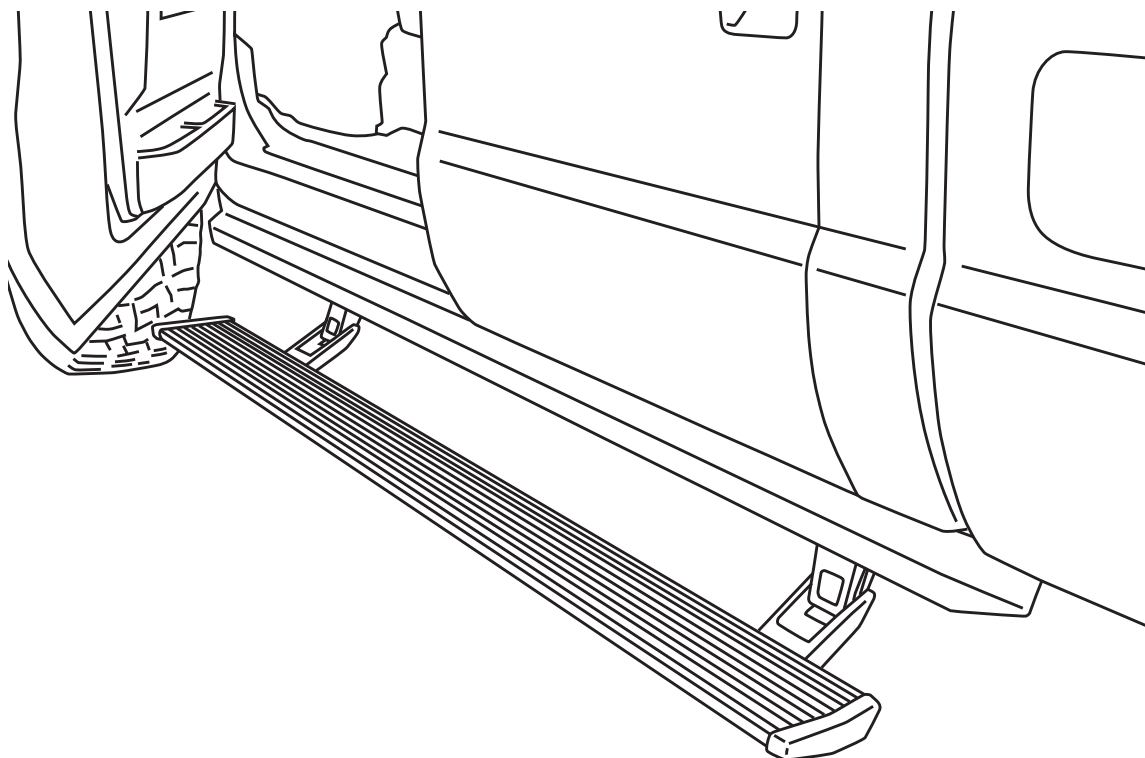

FINAL SYSTEM CHECK

Check that all doors activate the PowerStep and the LED lights work when doors open and close.

NORMAL OPERATION: When the doors open, PowerStep automatically deploys from under the vehicle.

When the doors are closed, PowerStep will automatically return to the stowed/retracted position. **Note that there is a 2-second delay before the PowerStep returns to the stowed/retracted position.**

CORRECT OPERATION OF LIGHTS: All four lamps will illuminate upon opening any door of vehicle. Lamps will stay on until restowing of both Power Steps or until 5 minutes has expired with the doors open. When the lights timeout after 5 minutes, they can be reilluminated by closing and opening any door of vehicle.

Thank you for your recent RealTruck purchase.

**REGISTER YOUR PRODUCT TODAY FOR
FASTER SERVICE & PRODUCT UPDATES**

Please visit:

<https://realtruck.com/warranty-registration/>
or scan the QR Code



Product Registration Benefits:

- Ensure we have your purchase receipt and product info in our system which is required for warranty.
- Faster and easier access to customer service and tech support in the unlikely event you need warranty or product support.
- Registration helps us keep you up to date on product information and offers.

To view other RealTruck products that may be offered for your vehicle.

Please visit: www.realtruck.com

Congratulations on your purchase of the genuine AMP Research PowerStep! Here's what you should know...

POWER-DEPLOYABLE RUNNING BOARDS OPERATION: AMP Research PowerStep running boards automatically move when the doors are opened to assist entering and exiting the vehicle.

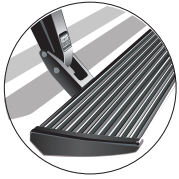

Automatic power deploy:

The running boards will extend down and out when the doors are opened.

Automatic power stow:

The running boards will return to the stowed position when the doors are closed. There will be a 2-second delay before the running boards move to the stowed position.



Automatic stop:

If an object is in the way of the moving running board, the running board will automatically stop. To reset, clear any obstruction, then simply open and close the door to resume normal operation.

Manually set in the deployed (OUT) position for access to the roof:

The running boards can be manually set in the deployed position by firmly holding the step down with your foot while at the same time closing the door. To resume normal operation, open and close the door.

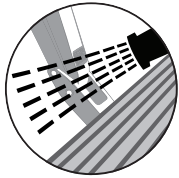

Maintenance: In adverse conditions, debris such as mud, dirt, and salt may become trapped in the running board mechanism, possibly leading to unwanted noise. If this occurs, manually set the running boards to the deployed position and flush the front and rear hinge arms with a high-pressure car wash wand.

Avoid spraying the motors directly. After washing, apply silicone spray lubricant to the hinge pivot pins. Do not apply silicone, wax or protectants like Armor All® to the running board stepping surface.

Caution! Keep hands away when the running board is in motion.

5-YEAR LIMITED WARRANTY

AMP RESEARCH warrants this product to be free from defects in material and workmanship for FIVE (5) YEARS FROM DATE OF PURCHASE, provided there has been normal use and proper maintenance. This warranty applies to the original purchaser only. All remedies under this warranty are limited to the repair replacement of the product itself, or the repair or replacement of any component part thereof, found by the factory to be defective within the time period specified. The decision to repair or replace is wholly within the discretion of the manufacturer.

This warranty specifically excludes labor. If you have a warranty claim, first you must call our factory at the number below for instructions. You must retain proof of purchase and submit a copy with any items returned for warranty work. Upon completion of warranty work, if any, we will return the repaired or replaced item or items to you freight prepaid. Damage to our products caused by accidents, fire, vandalism, negligence, misinstallation, misuse, acts of nature, or by defective parts not manufactured by us, is not covered under this warranty.

ANY IMPLIED WARRANTIES OF MERCHANTABILITY AND/OR FITNESS FOR A PARTICULAR PURPOSE CREATED HEREBY ARE LIMITED IN DURATION TO THE SAME DURATION AND SCOPE AS THE EXPRESS WRITTEN WARRANTY. OUR COMPANY SHALL NOT BE LIABLE FOR ANY INCIDENTAL OR CONSEQUENTIAL DAMAGE.

Some states do not allow limitations on how long an implied warranty lasts, or the exclusion or limitation of incidental or consequential damages, so the above limitations or exclusions may not apply to you. This warranty gives you specific legal rights, and you may also have other rights that vary from state to state.

FOR WARRANTY ISSUES WITH THIS PRODUCT PLEASE CALL REALTRUCK CUSTOMER SERVICE 1-888-983-2204

WARNING

Be sure to read and precisely follow the provided instructions when installing this product. Failure to do so could place the vehicle occupants in a potentially dangerous situation. After installing or reinstalling, re-check to insure that the product is properly installed.