

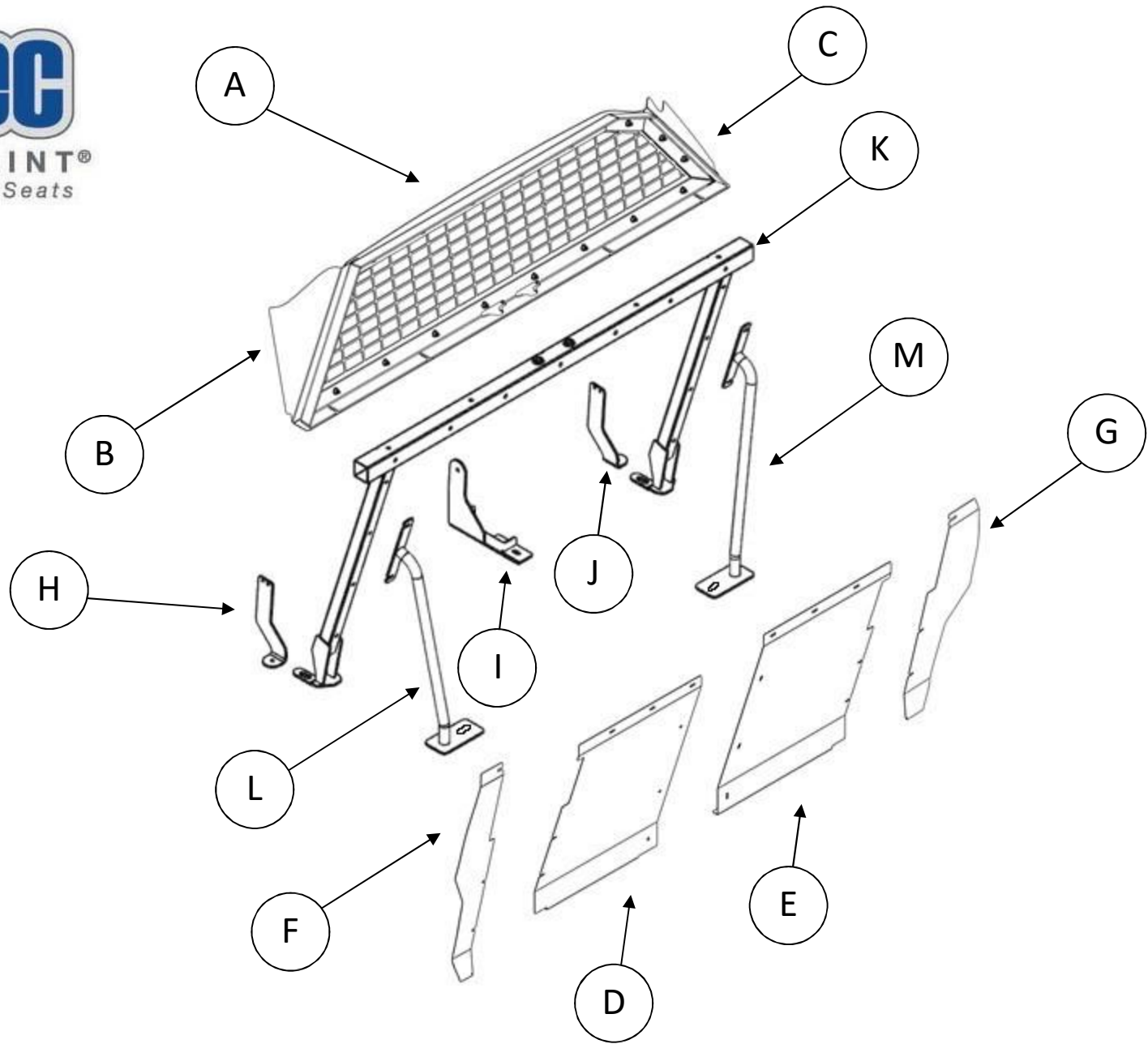

INSTALLATION INSTRUCTIONS CHEVROLET TAHOE SEAT WITH CENTER BELT; 5UT2111



ITEM	QTY	DESCRIPTION	ITEM	QTY	DESCRIPTION
A	1	Rear Window Assembly	H	1	Outer Buckle Bracket (Left Side)
B	1	Upper Filler Panel (Left Side)	I	1	Outer Buckle Bracket (Right Side)
C	1	Upper Filler Panel (Right Side)	J	1	Center Belt Bracket
D	1	Center Closeout Panel (Left Side)	K	1	Rear Crossbar
E	1	Center Closeout Panel (Right Side)	L	1	Floor Strut (Left Side)
F	1	Outer Closeout Panel (Left Side)	M	1	Floor Strut (Right Side)
G	1	Outer Closeout Panel (Right Side)			



PARTS INCLUDED IN THIS LIST:

Item	QTY	Description
1	8	Phillips Rounded Head Screw Number 6 X 1/2"
2	4	Countersink Screw Number 8 X 1/2"
3	11	Button Head Hex Drive Screw, 1/4"-20 X 1"
4	8	Split Lock Washer 1/4"
5	19	Flat Washer 1/4"
6	8	Nylon-Insert Locknut 1/4"-20
7	14	SEMS Button Head Hex Drive Screw 1/4"-20 x 3/4" X 1"
8	8	Hex Head Screw 1/4"-20 X 1 1/4"
9	1	Hex Head Screw 1/2"-13 X 1-1/2"
10	2	Flat Washer 1/2"
11	1	Nylon-Insert Locknut 1/2"-13
12	2	Hex Nut 1/2"-13
13	2	Hex Head Screw M10-1.5 X 35MM
14	6	Split Lock Washer M10
15	10	Flat Washer M10
16	2	Shoulder Screw 3/8"-16
17	4	Round Base Magnet

aedec
PRO-STRAINT®
Prisoner Safety Seats

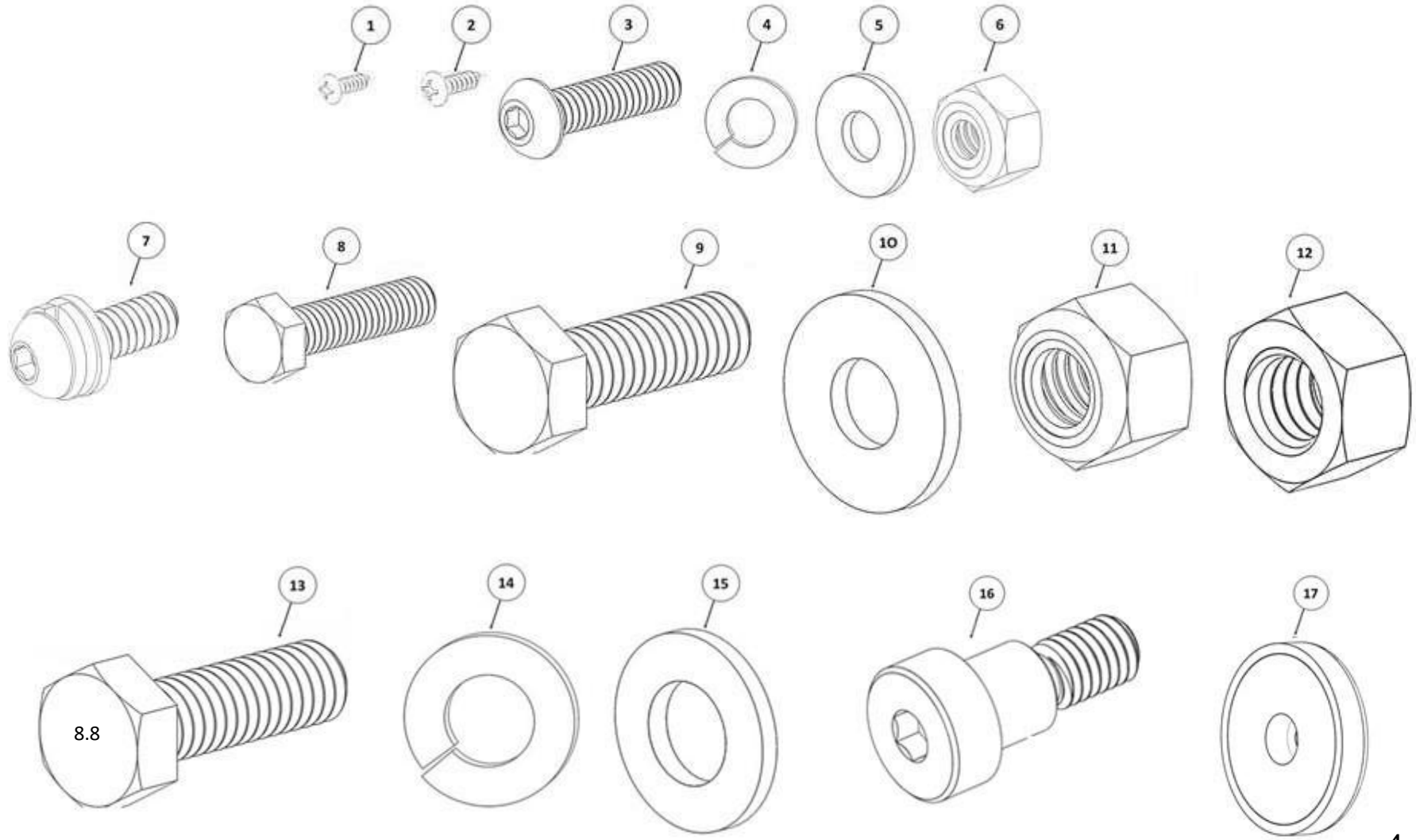



PARTS INCLUDED IN THIS LIST:

Item	QTY	Description
N	4	Waist Buckle
O	2	Buckle Trim Plate
P	2	Center Belt System
Q	2	Shoulder Buckle
R	1	Molded Prisoner Seat

TOOLS NEEDED FOR INSTALLATION:

- ✓ Inch & Metric Wrench Set
- ✓ Inch & Metric Socket Set
- ✓ T50 Torx Bit Socket
- ✓ 5/32" & 1/4" Hex Bit Socket
- ✓ Ratchet & Ratchet Extension
- ✓ 7mm Socket
- ✓ Tape Measure
- ✓ Drill Motor & 1" Hole Saw
- ✓ Razor Knife

ESTIMATED TIME FOR INSTALLATION: 1.5 – 2.0 Hours



N

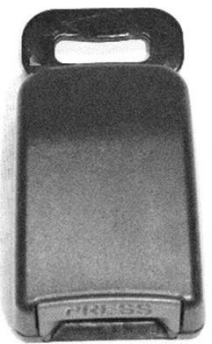

O

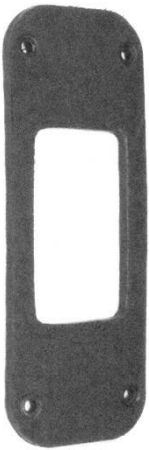

P



Q





**INSTALLATION INSTRUCTIONS
CHEVROLET TAHOE SEAT
WITH CENTER BELT; 5UT2111**

Important Notice: Read all instructions before starting the installation of the seat. Before drilling or installing any screw or fastener into the body of the vehicle it is imperative to ensure the drill bit or fastener will not penetrate any fuel line, fuel tank or brake lines.



INSTALLATION INSTRUCTIONS

PRODUCT SAFETY & LEGAL DISCLAIMER

- Read and understand all safety precautions and instructions before installing this product.
- **Review the product package and contents prior to beginning the installation.** We make every effort to provide a perfect product but we are human and a mistake may happen from time to time. Take care when opening the packaging and removing items. If a return is needed you will want to return the product in its original packaging if possible.
- This product is intended to be installed by a certified technician, therefore a certain level of competence and knowledge are assumed when reading these instructions.
- This instruction guide is provided as a GENERAL installation guide, some vehicles vary dimensionally and may require additional steps.
- **Make certain to completely unpack the contents of the shipping container. Unwrap all parts and inspect parts prior to installing.**
- Test fit the product on the vehicle prior to any third party modifications and or finishing. The manufacturer and distributors will not accept responsibility for third party charges, labor and or third part replacement modifications. Some modifications may void the factory warranty.
- Exercise due-diligence when installing this product. The manufacturer and distributors of this product will not accept any responsibility for vehicle damage or personal injury resulting from the installation of this product. Installation of this product is acceptance of this statement and releases the manufacturer/Distributors of this product from any direct or indirect liabilities.
- Careless installation and operation can result in serious injury or equipment damage.
- Once installation is complete, please return this guide along with other documentation included in this product back to the consumer for future reference. The manufacturer/distributors of this product do not guarantee this particular version will be available at a later date.
- All liability for installation and use rests with the owner/operator.



INSTALLATION INSTRUCTIONS

INJURY HAZARD

Please complete a shop and tool inspection prior to beginning the installation.

- Always make sure you have a clean, dry and well-lit work area.
- Always remove jewelry, loose fitting clothing and wear protective gloves and eye protection.
- Always use extreme caution when jacking or raising a vehicle for work. Set the emergency brake and use tire/wheel blocks and jack stands. Refer to the vehicle manufacturer handbook. Utilize the vehicle manufacturers designated lifting points.
- Always use appropriate and adequate care in lifting parts during disassembly and installation. Seek help in lifting heavy or large items into place. Utilize jacks and or lifting devices when available.
- Always ensure products are secure during disassembly and installation.
- Always wear eye protection and take steps to protect any exposed skin during the installations. Drilling, cutting and grinding plastic and metal may create flying particles that can cause injury.
- Always use extreme caution when drilling, cutting and or grinding on a vehicle. Thoroughly inspect the area to be drilled, cut or ground both on the bottom and top of the surface. Ensure no wires, exhaust or any type of liquid lines will or can be damaged while drilling, cutting or grinding. If objects that are not intended to be drilled or cut are in the way of the hole or cut, they will need to be relocated.
- Always assemble and tighten all fasteners per the installation instructions.
- Always route electrical cables carefully. Avoid moving parts, parts that may become hot and rough or sharp edges.
- Always insulate and protect all exposed wiring and electrical connections.

MAINTENANCE AND CARE

- Never use abrasive cleaners or polish compounds. Clean with a gentle soap and water.



INSTALLATION INSTRUCTIONS:

Step-1 Remove the plastic trim pieces from the front side of the second row seats to gain access to the front screws.

Step-2 Using a T50 Torx driver, remove the (4) screws from the front of the second row seat rails.

Step-3 Tumble the seats forward. Using a T50 Torx driver, remove the (5) screws from the rear of the second row seat rails.

Step-4 Remove both seats from the vehicle. Retain (8) of the second row seat screws as they will be reused.

Step-5 Remove the tire change tool kit, then use a 5.5mm socket to remove the stud from the floor of the vehicle.

Step-6 Unscrew and remove the plastic cap from the stud on the passenger side floor of the vehicle.



Step-7 Installing the Shoulder Buckles. First remove the “C” Pillar trim. Using a small to medium flat tip screw driver, pop out the small plastic cap near the front top portion of the trim.
{Fig 1.}

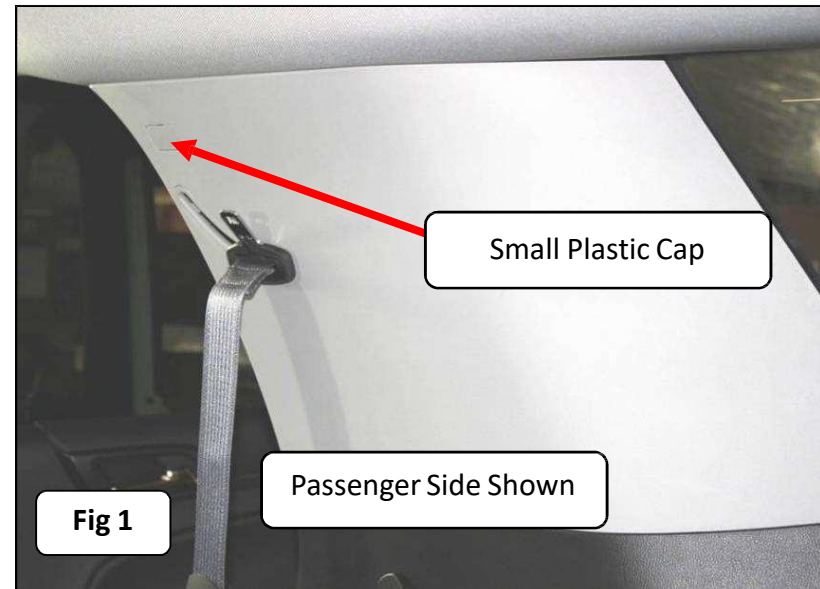

Step-8 Using a 7mm socket remove the screw holding the trim to the vehicle as seen in {Fig 2}. **NOTE:** When removing this screw, be careful not to drop it, as it can fall behind the entire side trim piece, making it difficult to find. Then pulling the trim straight out, unsnap the trim from the vehicle. **CAUTION:** The airbag is behind this trim piece, use due caution while manipulating anything in this area.





Step-9 With the OEM Seat Belt Loop exposed, as seen in {Fig 3}; remove it using a 50 Torx driver. Keep the factory hardware as it will be used again in the installing of the Shoulder buckle.

NOTE: the entire retractor can be removed by removing the bottom trim, exposing the retractor and removing it but **RECOMENDED**, fold up the belt and loop, securing it with either a zip tie or rubber band and securely storing it down behind the bottom trim.

Step-10 With the OEM belt loop removed, install (1) [Item Q] Shoulder Buckle, slide the anchor plate through the slot in the trim, {Fig 4}. **NOTE:** The slot in the buckle end must be on top of the buckle release button, {Fig 5}. This will allow the release button to be accessible when the belt is engaged.

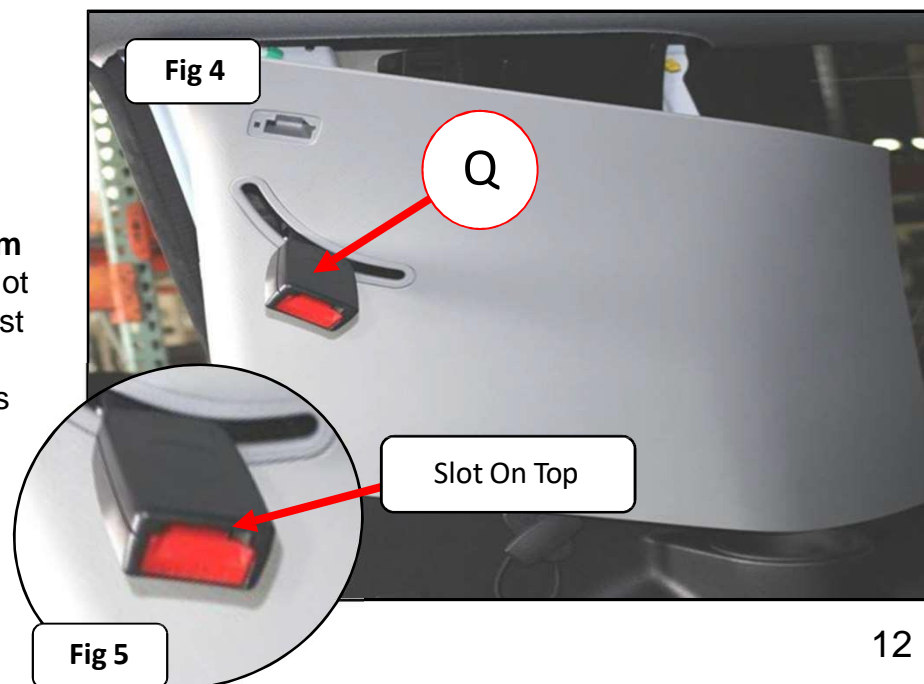



Step-11 Using the OEM bolt and spacer install [Item Q] Shoulder Buckle, back into the factory hole and tighten securely, {Fig 6}. Then reinstall the plastic "C Pillar" trim and small plastic cap. Repeat for the Drivers side of the vehicle.

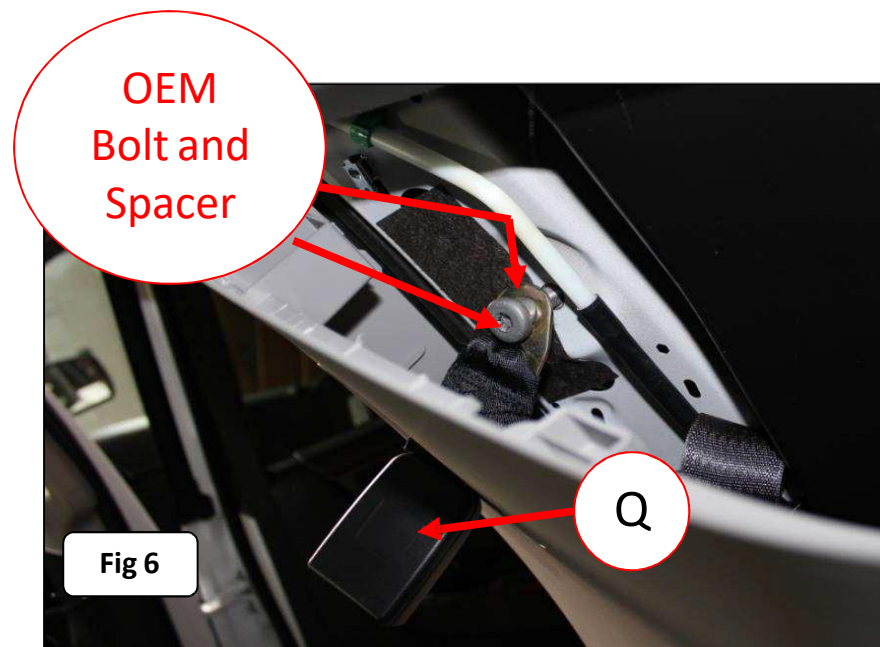



INSTALLATION INSTRUCTIONS:

Step-12 On each side of the vehicle, use a razor knife to cut and remove the area shown from the rubber mat and pad, {Fig 7 & 8}.

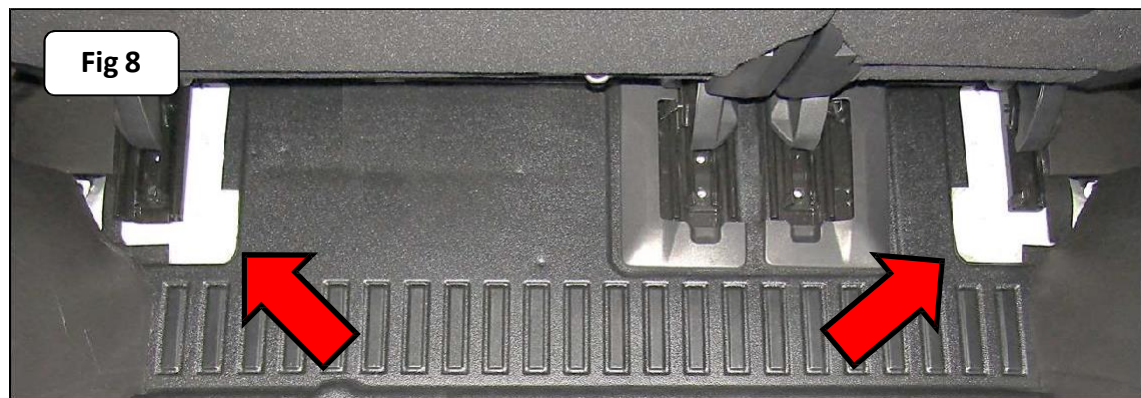
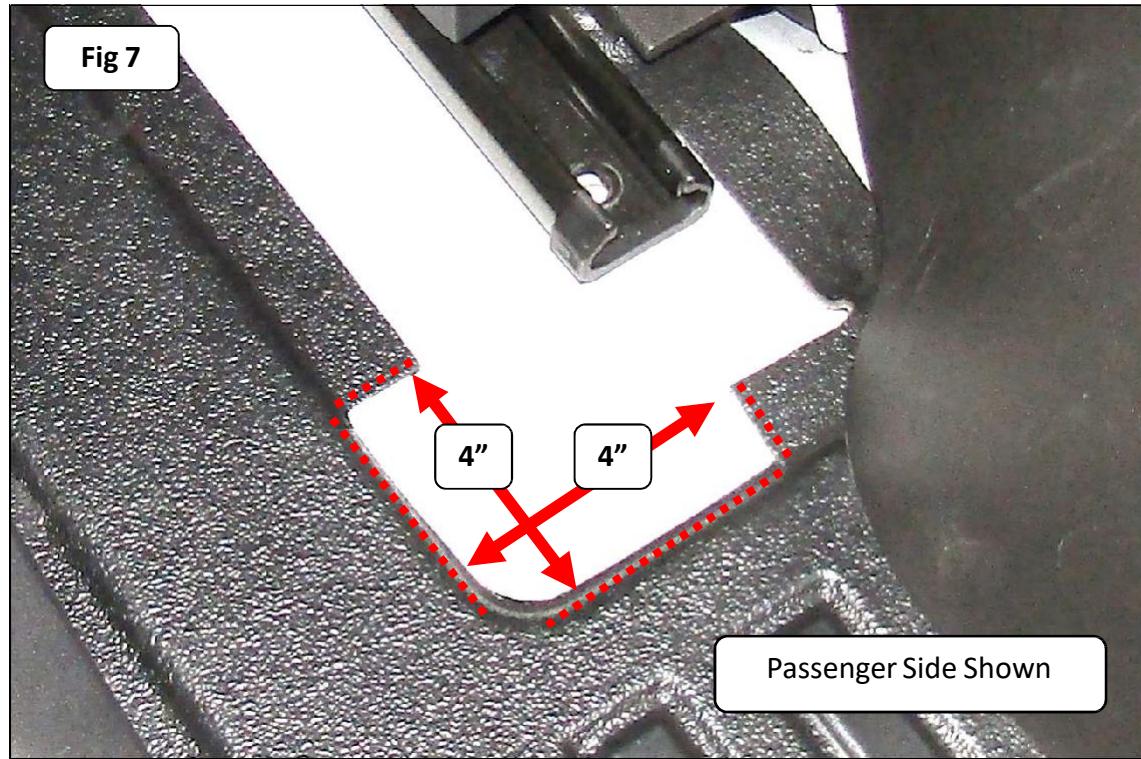



INSTALLATION INSTRUCTIONS:

Step-13 On each side of the vehicle, measure and mark the attachment point location for the floor struts on the top side of the cargo area rubber mat. Next use a 1" hole saw, and carefully apply enough pressure to only drill through the rubber mat and pad at the center of the marked location, {Fig 9}.

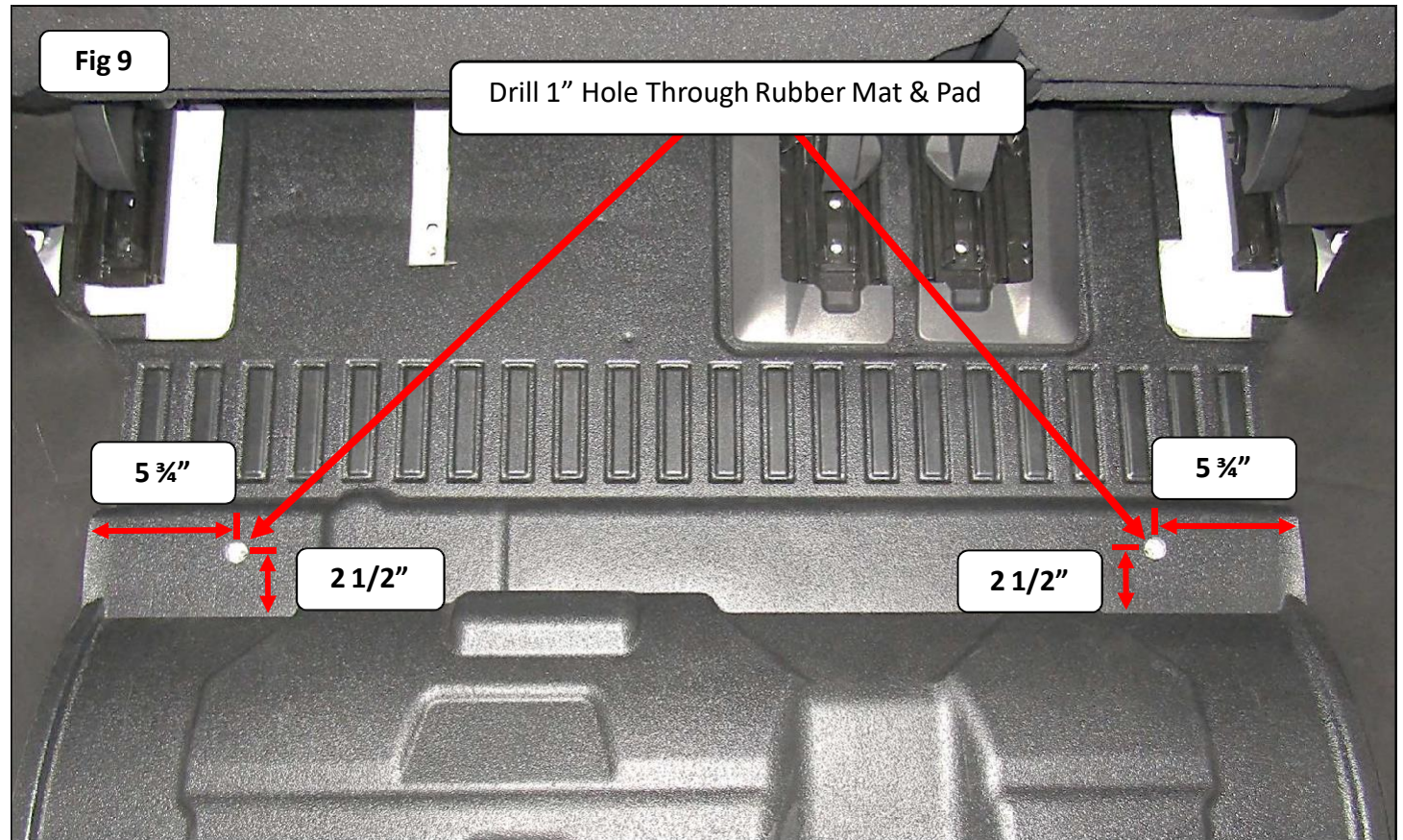

Fig 10

INSTALLATION INSTRUCTIONS:

Step-14 Attach (1) Buckle to each Outer Buckle Bracket using (2) Button Head Hex Drive Screw, 1/4"- 20 X 1", (2) Flat Washer 1/4" and (2) Nylon-Insert Locknut 1/4"- 20, {Fig 10}.

Note: Fully tightened the Button Head Screws and Nylon-Insert Locknuts, then loosen the Nylon-Insert Locknuts a full turn to allow the Buckle to slide freely front to back and tilt slightly from side to side on the Outer Buckle Bracket.





INSTALLATION INSTRUCTIONS:

Step-15 With assistance, position the Rear Crossbar in the vehicle. Place the Outer Buckle Bracket (Left Side) and Buckle assembly on top of the Rear Crossbar foot bracket, Align the hole in the Outer Buckle Bracket (Left Side) and Rear Crossbar foot bracket with the threaded insert in the floor of the vehicle used for the rear seat rail attachment. Install (1) OEM Seat Screw, (1) Split Lock Washer M10 and (1) Flat Washer M10 to secure the Rear Crossbar and Outer Buckle Bracket in place, (Fig 11 & 12). Do not tighten the OEM Seat Screw. Repeat for the passenger side.

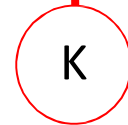
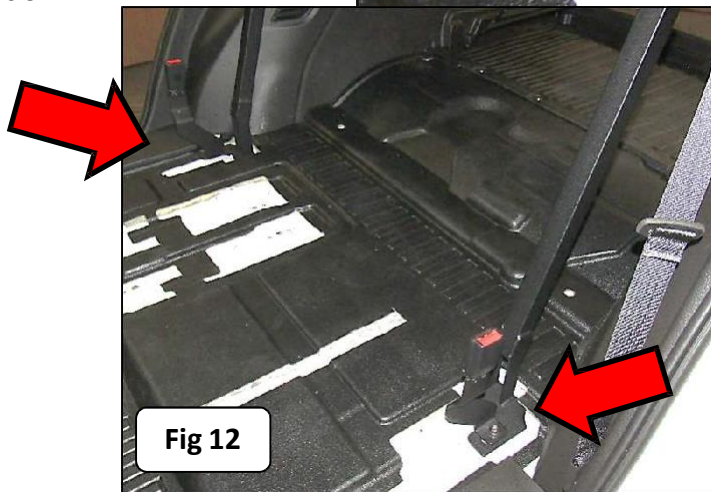
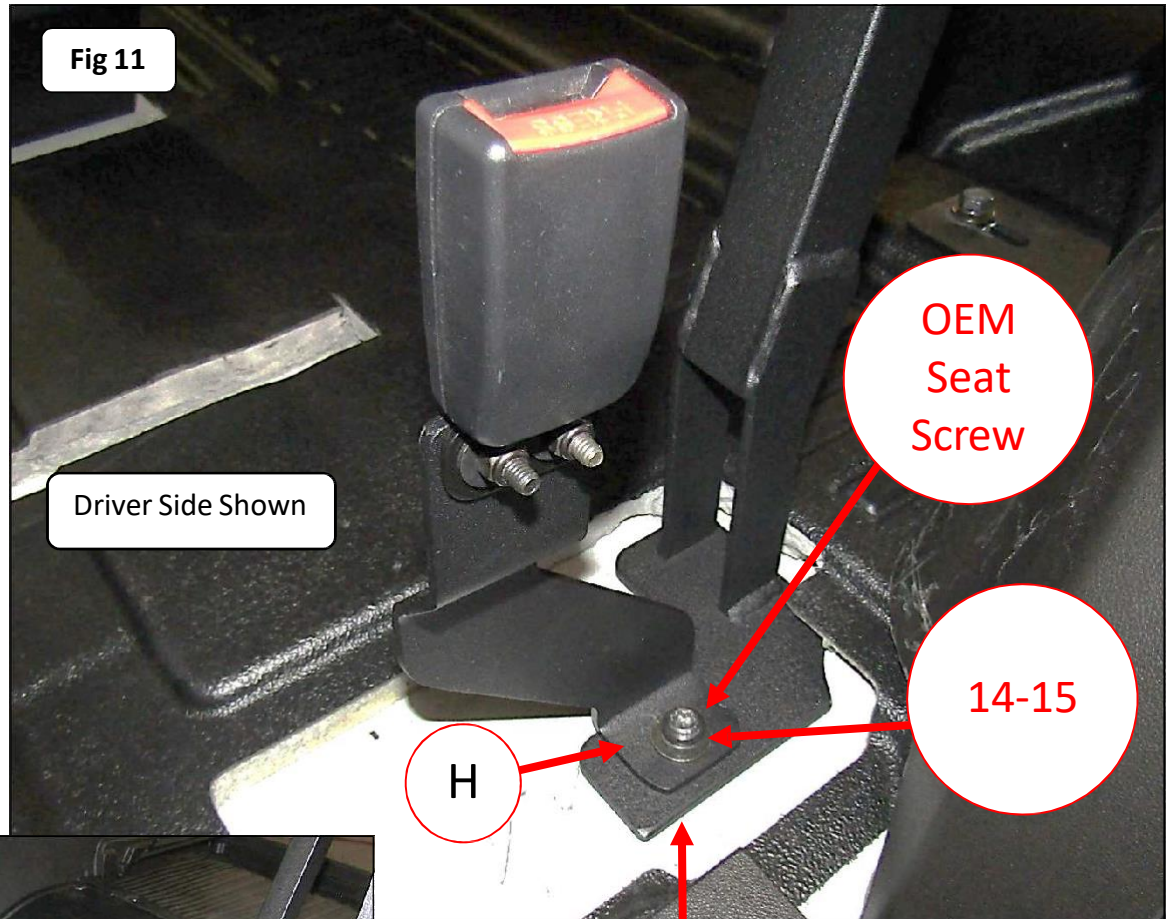



INSTALLATION INSTRUCTIONS:

Step-16 Install Center Belt Bracket. Align the (2) slot holes in the Center Belt Bracket with the threaded inserts in the floor of the vehicle used for the rear seat rail attachment. Attach the Center Belt Bracket using (2) OEM Seat Screws, (2) Split Lock Washers M10 and (2) Flat Washers M10, {Fig 13}. Do not tighten the OEM Seat Screws.

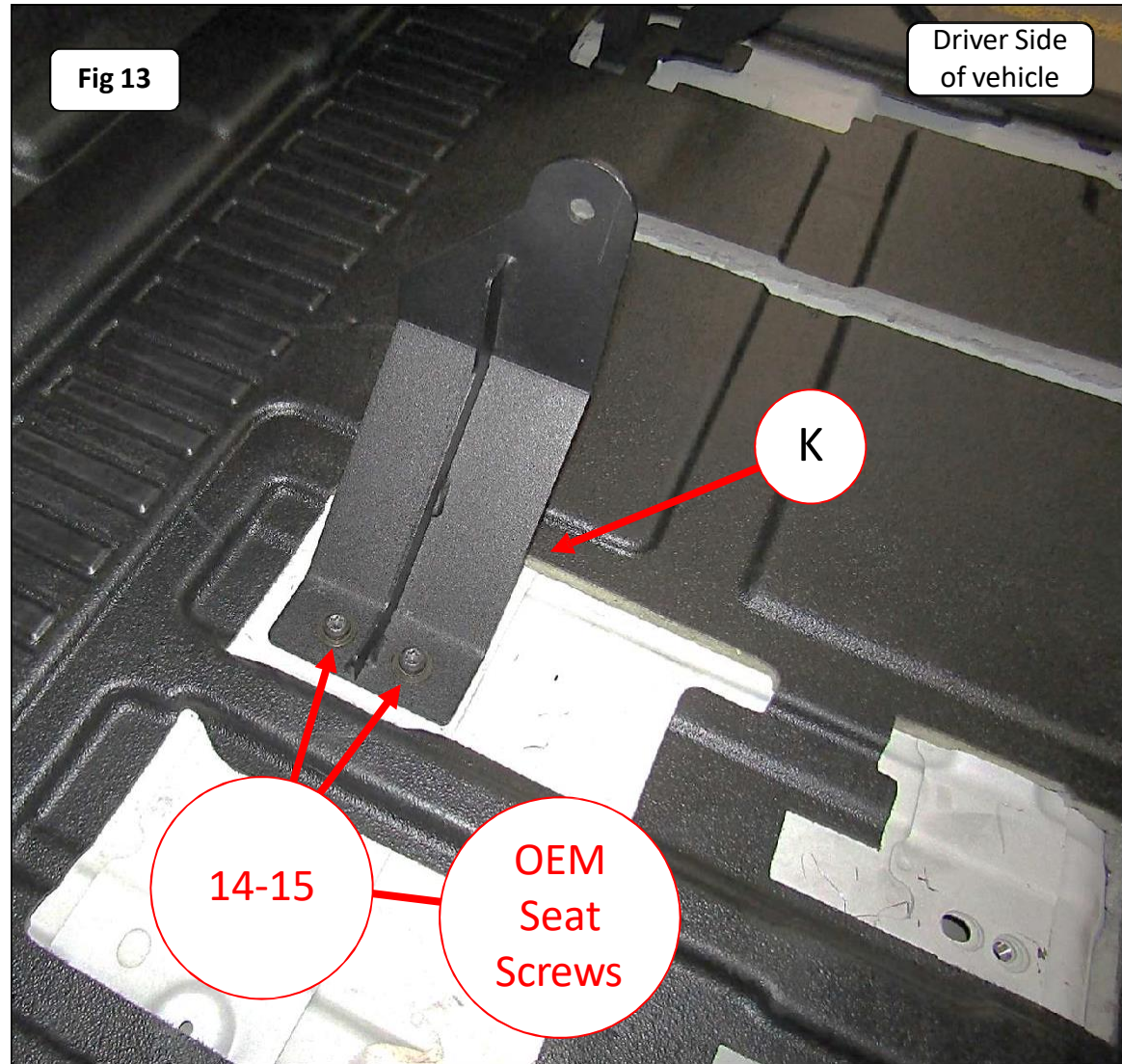



INSTALLATION INSTRUCTIONS:

Step-17 Place (1) Hex Nut 1/2"-13 in each hole drilled through the rubber floor mat and pad, {Fig 14 & 15}.

Note: The Hex Nut 1/2"-13 is used as a spacer.

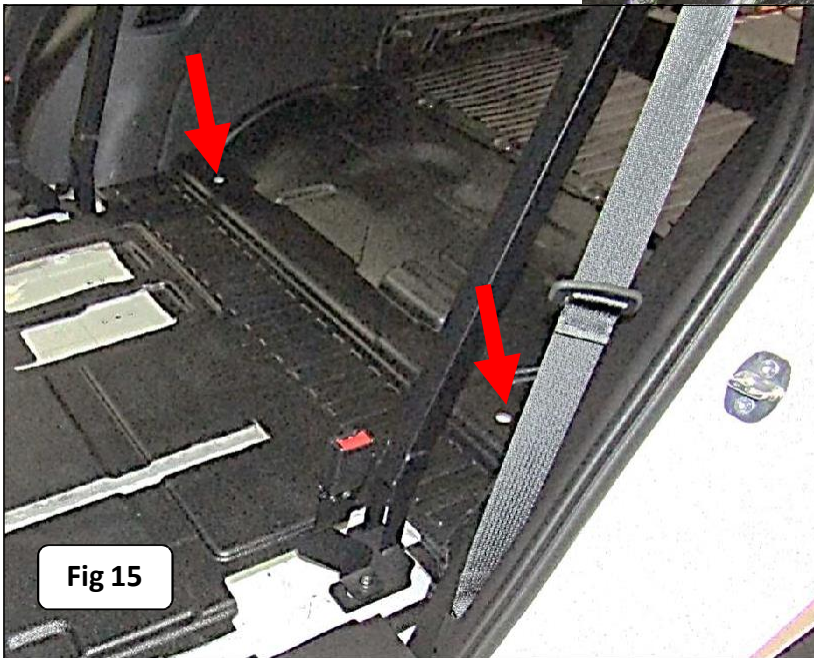
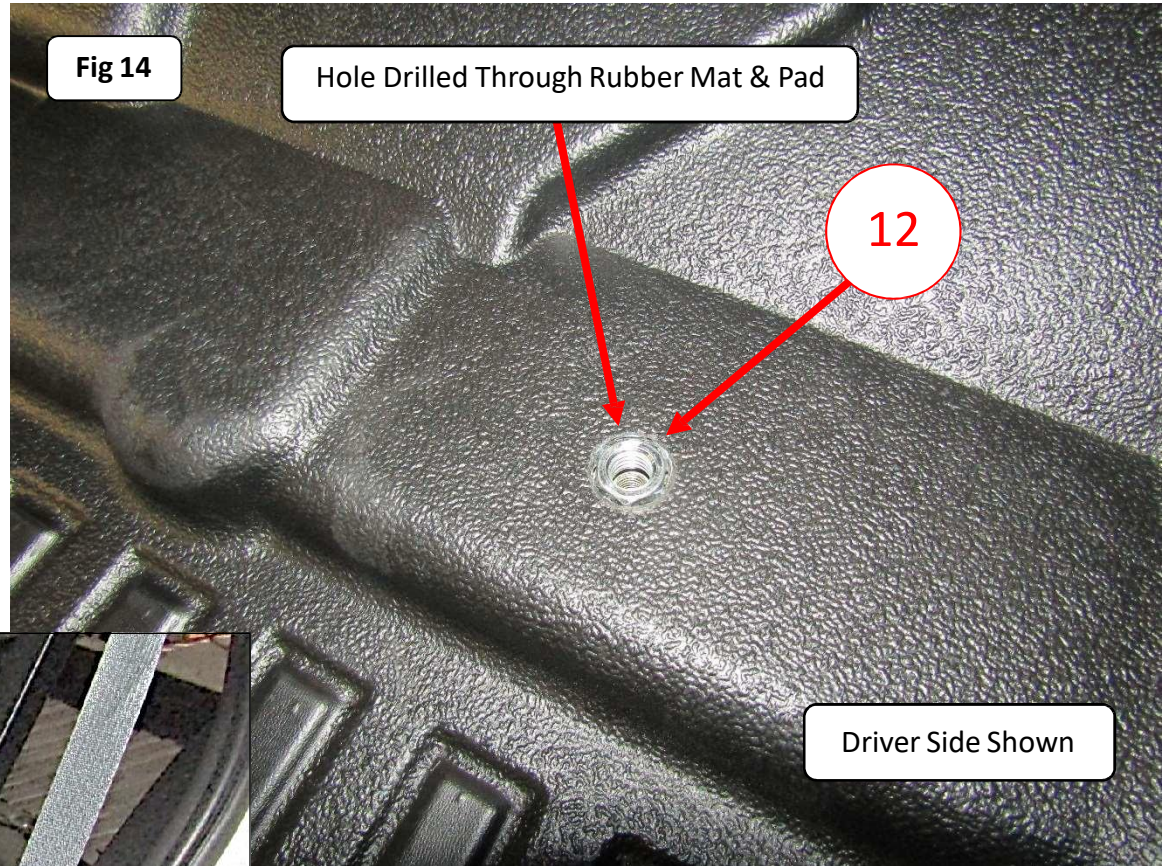



INSTALLATION INSTRUCTIONS:

Step-18 Install the Floor Strut (Left Side). Align the slots in the upper bracket of the Floor Strut (Left Side) with the rivet-nuts installed in the vertical tube of the Rear Crossbar. Attach the Floor Strut (Left Side) to the vertical tube of the Rear Crossbar using (2) Hex Head Screw 1/4"-20 X 1 1/4", (2) Split Lock Washer 1/4" and (2) Flat Washer 1/4", {Fig 16 & 17}. Do not tighten the Hex Head Screws.

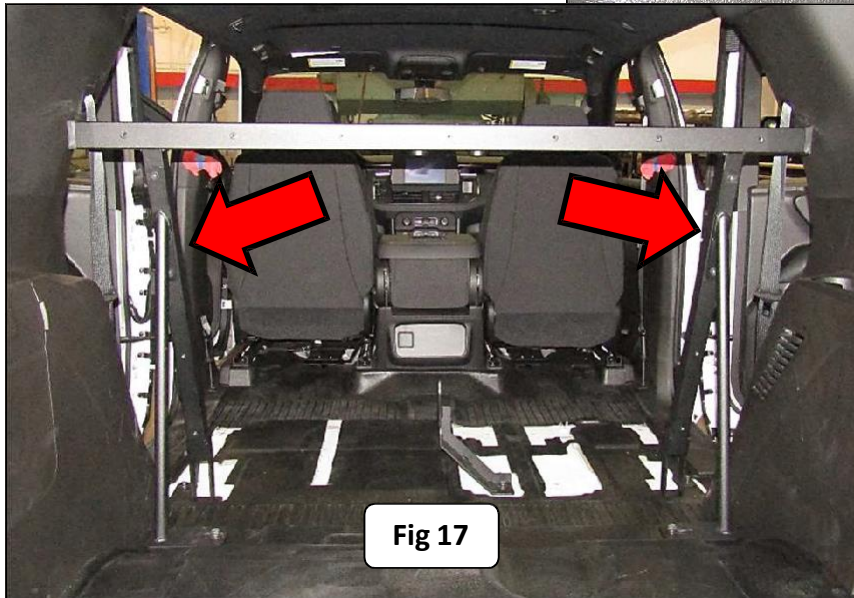
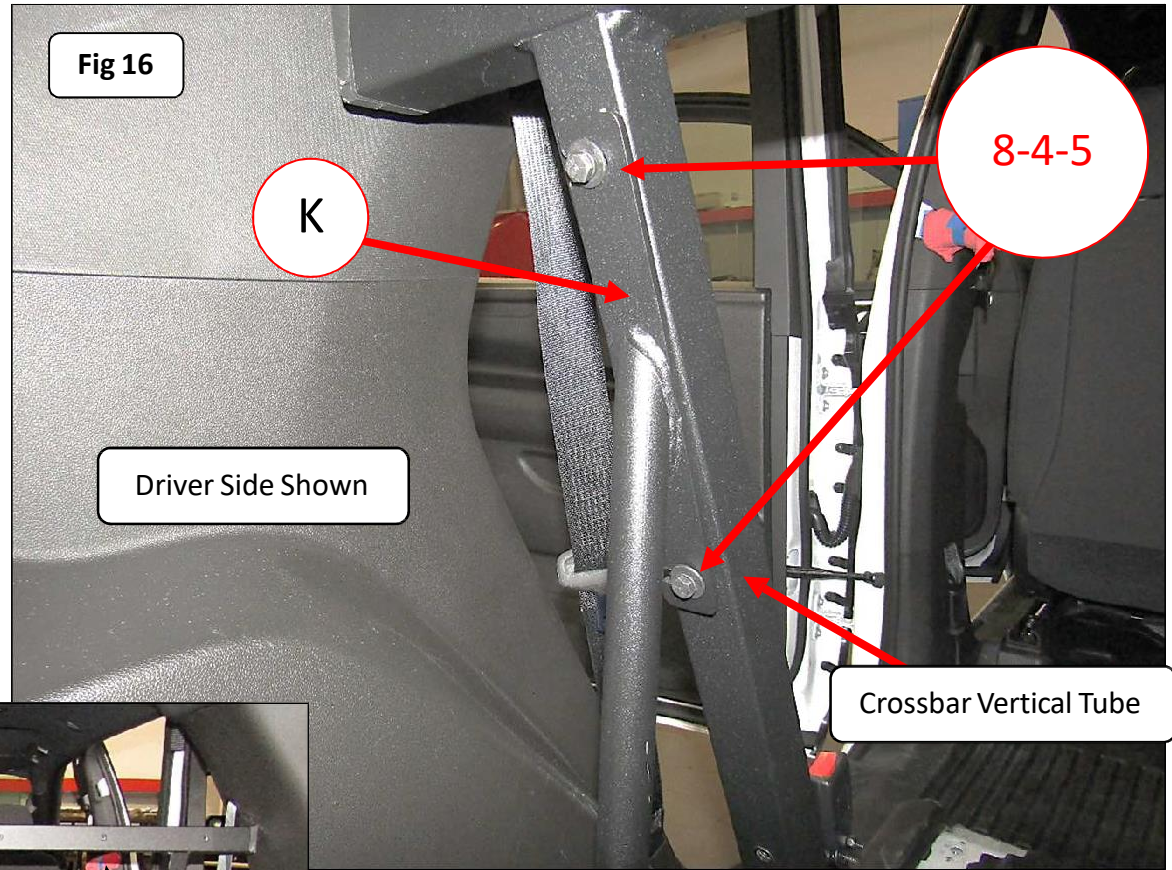



INSTALLATION INSTRUCTIONS:

Step-19 Align the slot hole in the base plate at the opposite end of the Floor Strut (Left Side) with the Hex Nut 1/2"-13 placed in the rubber mat and the threaded insert in the floor of the vehicle. Attach the Floor Strut (Left Side) base plate to the floor of the vehicle using (1) Hex Head Screw M10-1.5 X 35MM, (1) Split Lock Washer M10 and (1) Flat Washer M10, {Fig 18 & 19}. Do not tighten the Hex Head Screw. Repeat step 18 and 19 to install the Floor Strut (Right Side).

NOTE: Prior to tightening the Hex Head Screw adjust the strut either inboard or outboard to draw the mating upper edge of the seat against the C pillar.

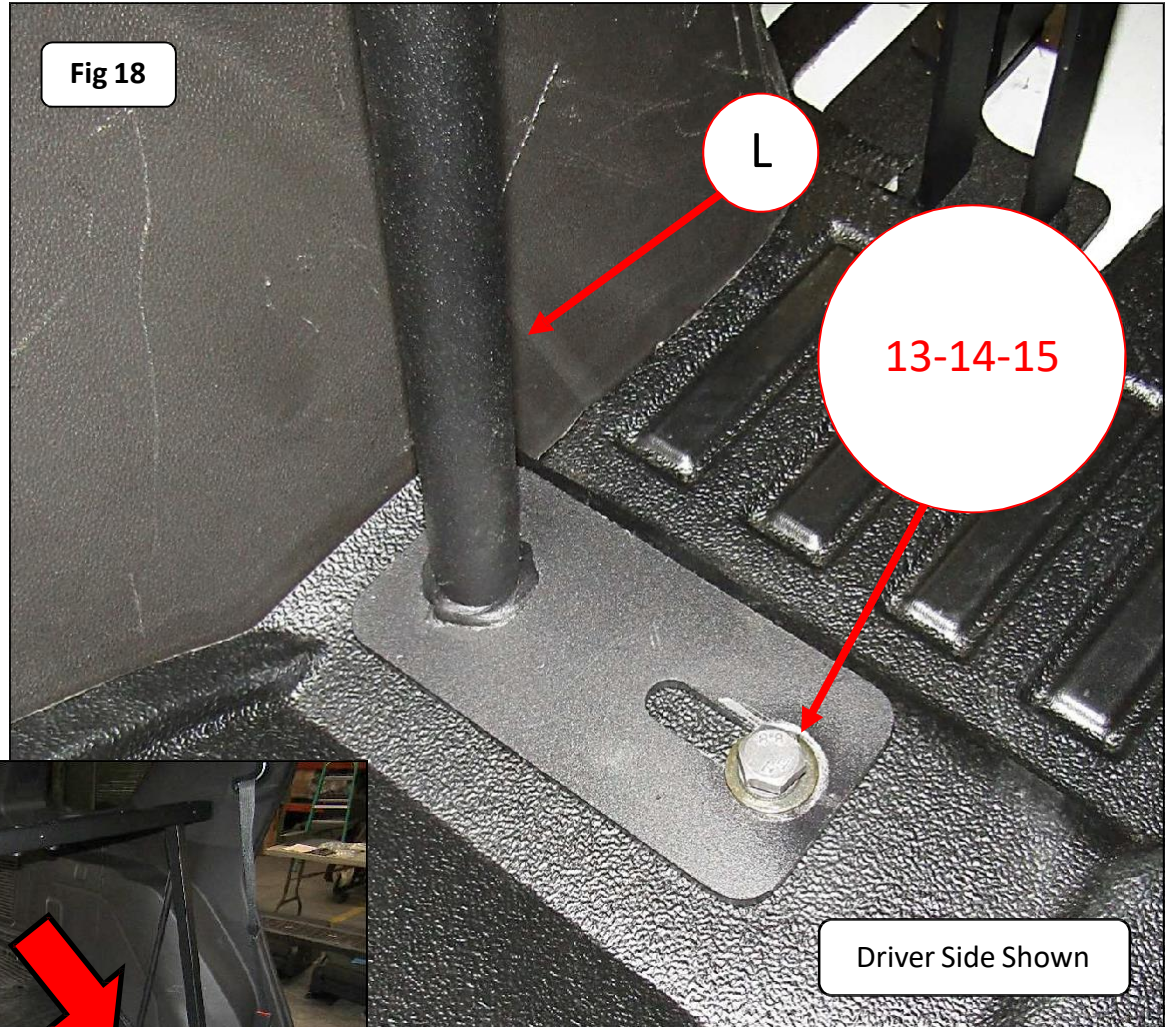

Fig 18

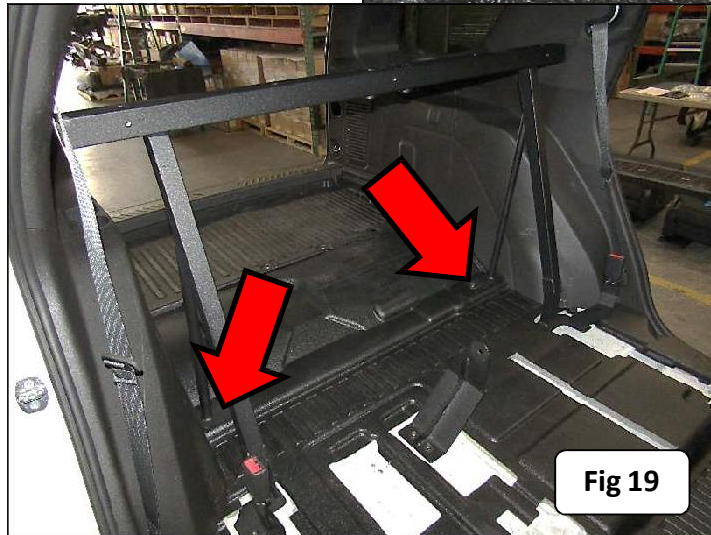

Fig 19



INSTALLATION INSTRUCTIONS:

Step-20 With assistance, place the Molded Prisoner Seat in the vehicle so the Buckles attached to the Outer Buckle Bracket protrude through the rectangular opening in each side of the Molded Prisoner Seat. Align the (3) holes in the upper front of the Molded Prisoner Seat with the rivet-nuts installed in the Rear Crossbar and attach the Molded Prisoner Seat to the Rear Crossbar using (3) Button Head Hex Drive Screw, 1/4"-20 X 1" and (3) Flat Washers 1/4", {Fig 20}. Do not tighten the Button Head Screws.

R

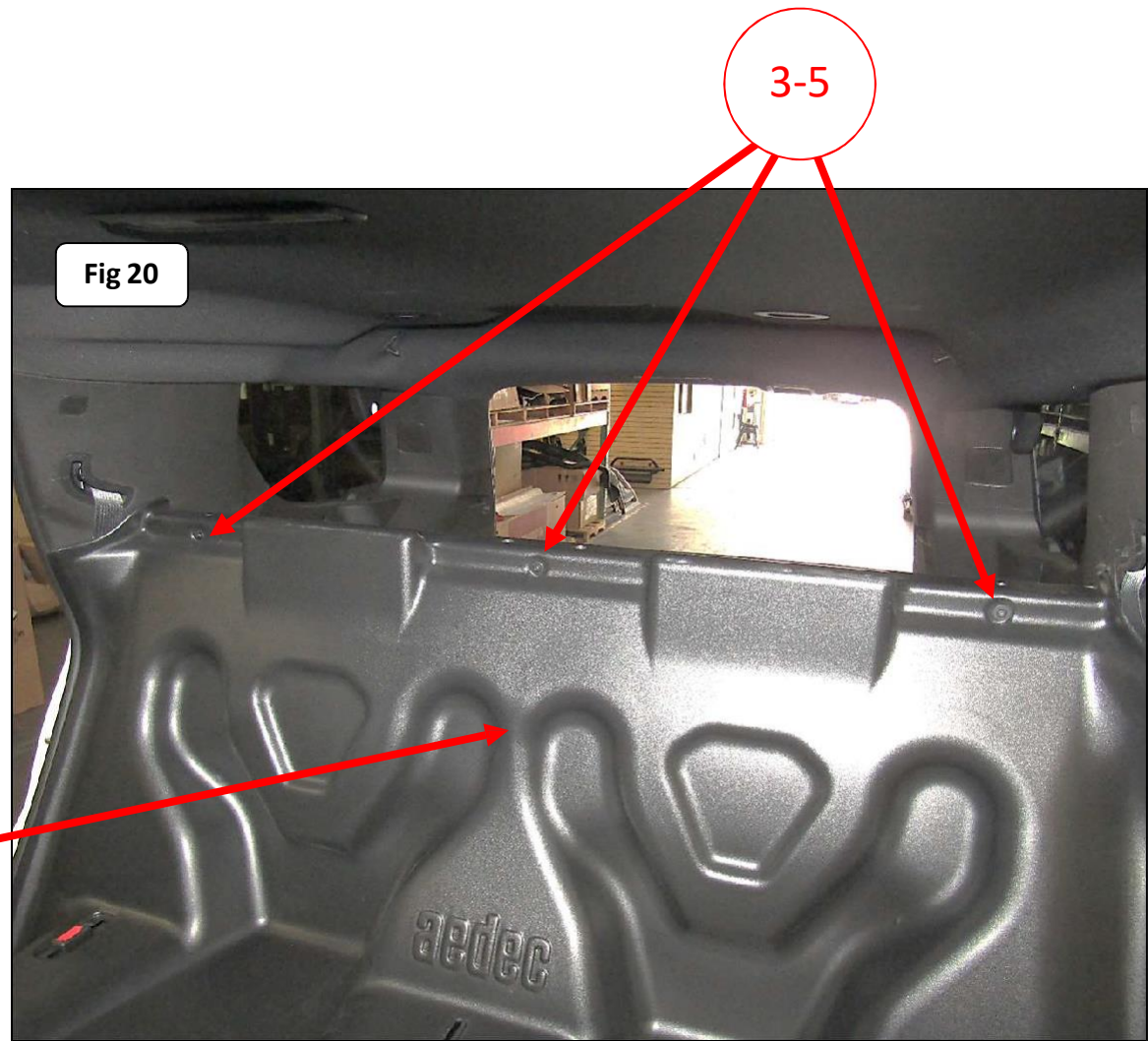



INSTALLATION INSTRUCTIONS:

Step-21 Align the holes in the base of the Molded Prisoner Seat with the threaded inserts in the floor of the vehicle and attach the Molded Prisoner Seat to the floor of the vehicle using (4) OEM Seat Screws and (4) Flat Washers M10, {Fig 21}. Ensure the distance from the front bottom flange of the seat and the jog of the door is 2-7/16" +/- 1/16" on both sides of the seat. Do not tighten the OEM Seat Screws.

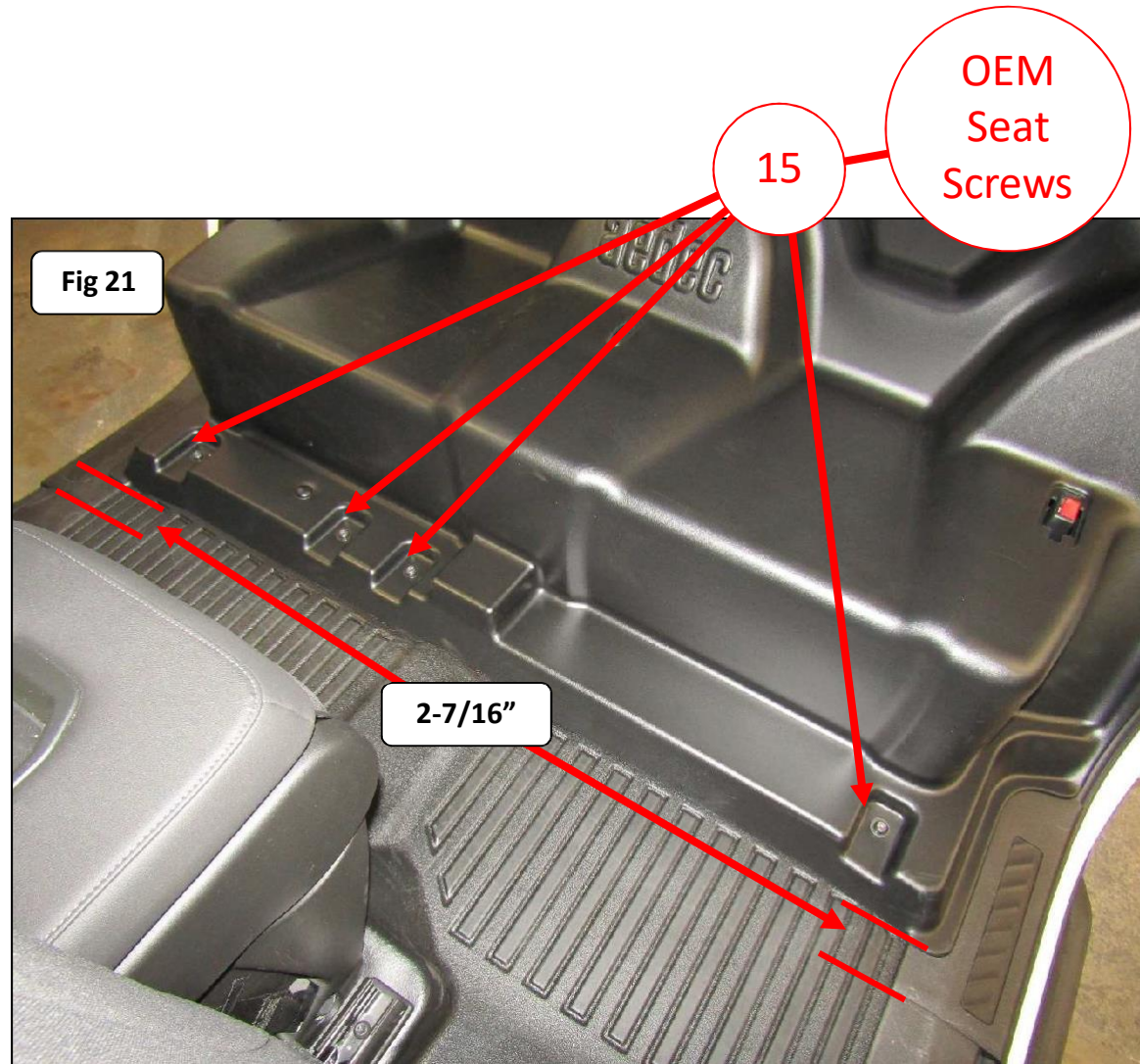



INSTALLATION INSTRUCTIONS:

Step-22 Install the (2) {Item P} Center Belts. (1) {Item P} Center Belt goes on each side of the Center Belt Bracket. Feed the anchor plate through the Molded Prisoner Seat belt slot at the inboard side of the seat. Attach anchor plate to the Center Belt Bracket using (1) Hex Head Screw 1/2"-13 X 1-1/2", (2) Flat Washer 1/2" and (1) Nylon-Insert Locknut 1/2"-13, {Fig 22}. Tighten the Nylon-Insert Locknut and Hex Head Screw.

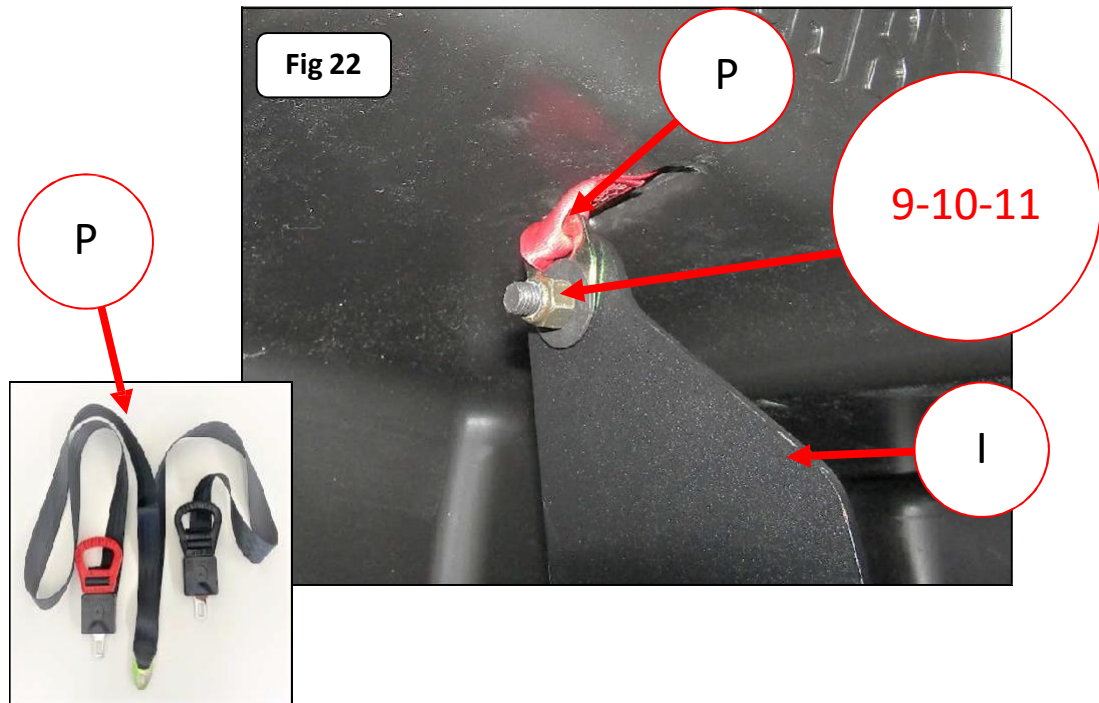

INSTALLATION INSTRUCTIONS:

Fig 23

Step-23 Loosen the nuts and screws on each side of the Rear Window Assembly. Align the slots with the screws and slide Upper Filler Panels into position between the Rear Window Assembly frame and the mesh screen then retighten the nuts and screws, {Fig 23}.

Note: Make sure to peel off and/or remove the protective film from the Upper Filler Panels before installing.

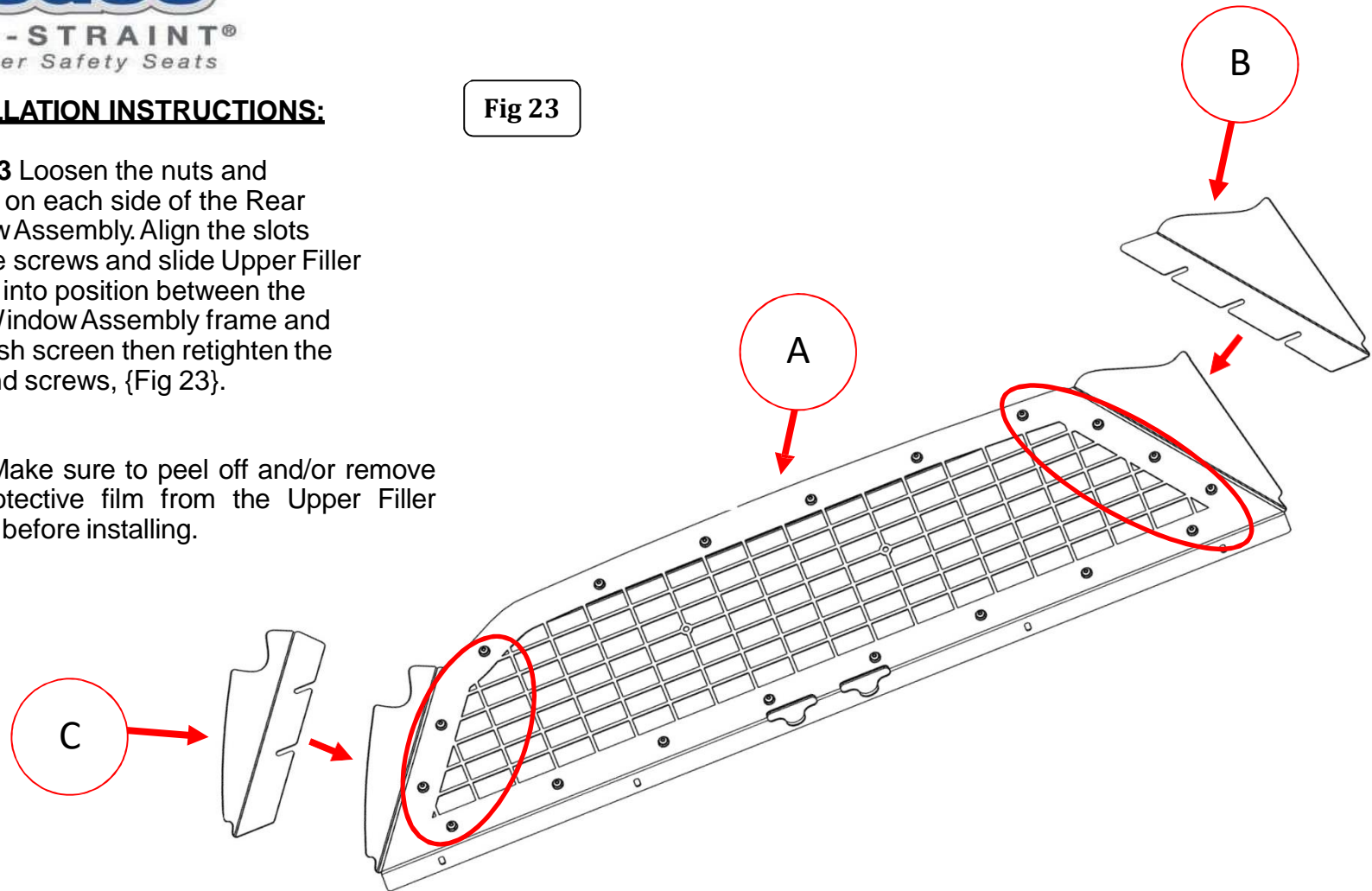

INSTALLATION INSTRUCTIONS:

Step-24 With assistance, from the rear passenger area of the vehicle, position the Rear Window Assembly on the top of the Molded Prisoner Seat then align the (4) holes in the Rear Window Assembly frame, with the holes in the Molded Prisoner Seat and the rivet-nuts in the Rear Crossbar. Attach the Rear Window Assembly frame to the Rear Crossbar main tube using (4) Hex Head Screws 1/4"-20 x 1 1/4", (4) Lock Washers 1/4" and (4) Flat Washers 1/4", {Fig 24}.

Tighten all nuts and screws.

Fig 24

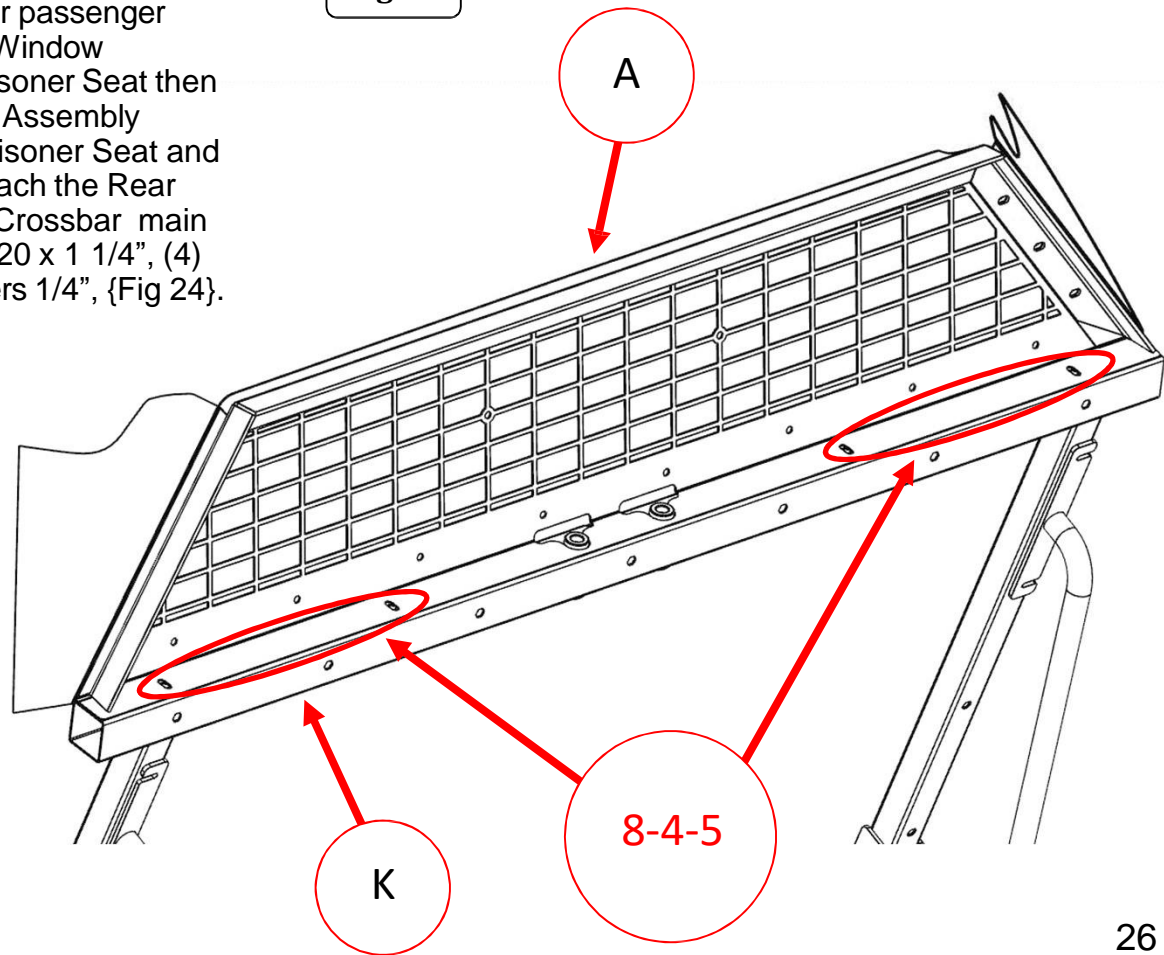

INSTALLATION INSTRUCTIONS:

Step-25 Align the holes in the top of Center Closeout Panel (Left Side) with the rivet-nuts installed in the crossbar main tube and attach the Closeout Panel to the Rear Crossbar main tube using (2) SEMS Button Head Hex Drive Screw 1/4"-20 x 3/4". Do not tighten the screws.

Step-26 Align the holes in the top of the Center Closeout Panel (Right Side) with the rivet-nuts installed in the Rear Crossbar main tube and attach the Closeout Panel to the Rear Crossbar main tube using (3) SEMS Button Head Hex Drive Screw 1/4"-20 x 3/4", then attach the Center Closeout panel (Right Side) to the rivet-nuts in the Center Closeout Panel (Left Side) to using (3) SEMS Button Head Hex Drive Screw 1/4"-20 x 3/4". Do not tighten the screws.

Step-27 Align the holes in the Closeout panel (Left Side) with the rivet-nuts installed in the in the Rear Crossbar main tube and vertical tube. Attach the Closeout Panel to the Rear Crossbar main tube and vertical tube using (3) SEMS Button Head Hex Drive Screw 1/4"-20 x 3/4". Repeat for the Closeout Panel (Right Side). Tighten all screws.

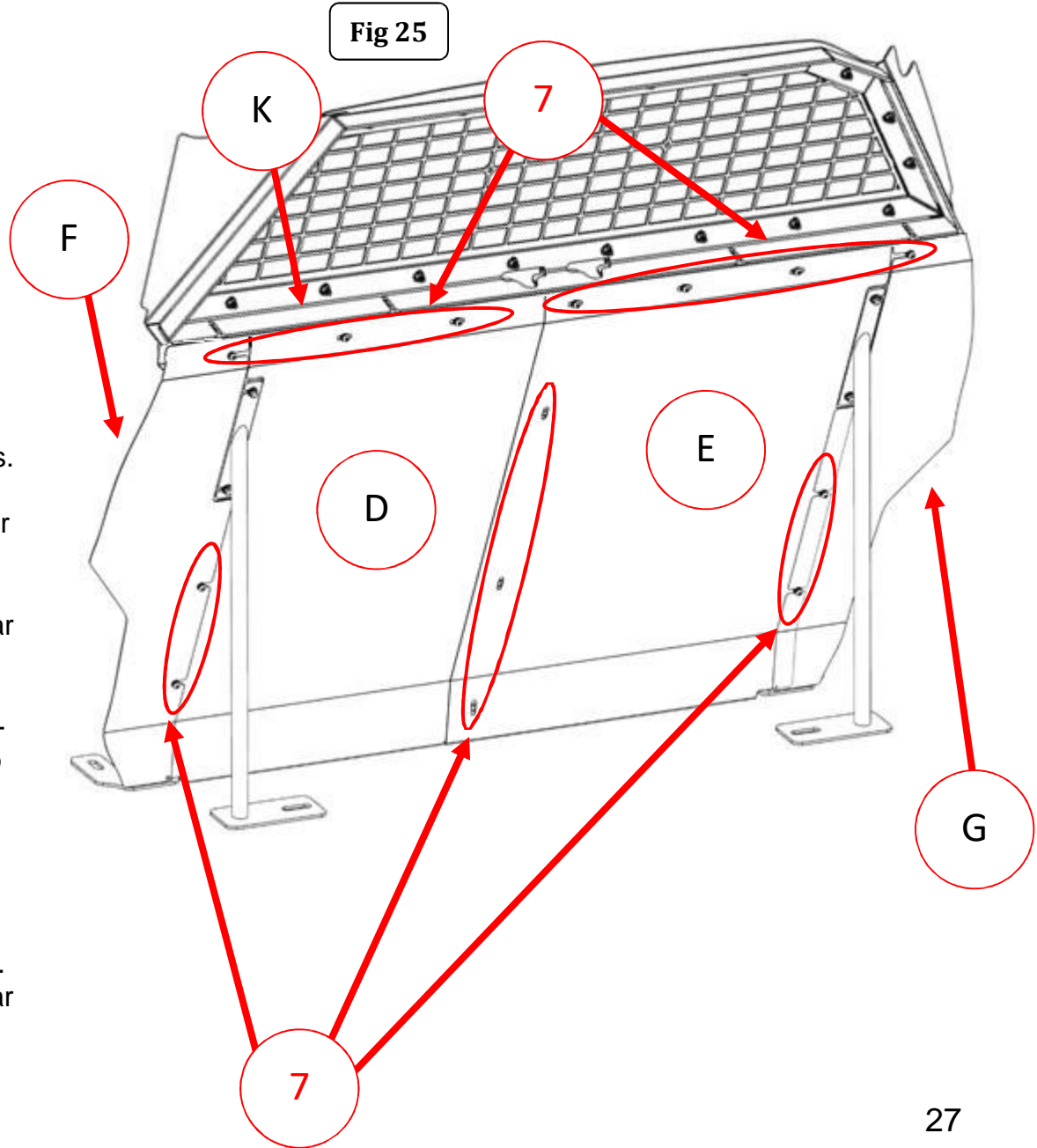



INSTALLATION INSTRUCTIONS:

Step-28 Attach the Buckle Trim Plate to the Molded Prisoner Seat using the Phillips Rounded Head Number 6 1/2" screws provided (4 for each trim plate), {Fig 26 & 27}.

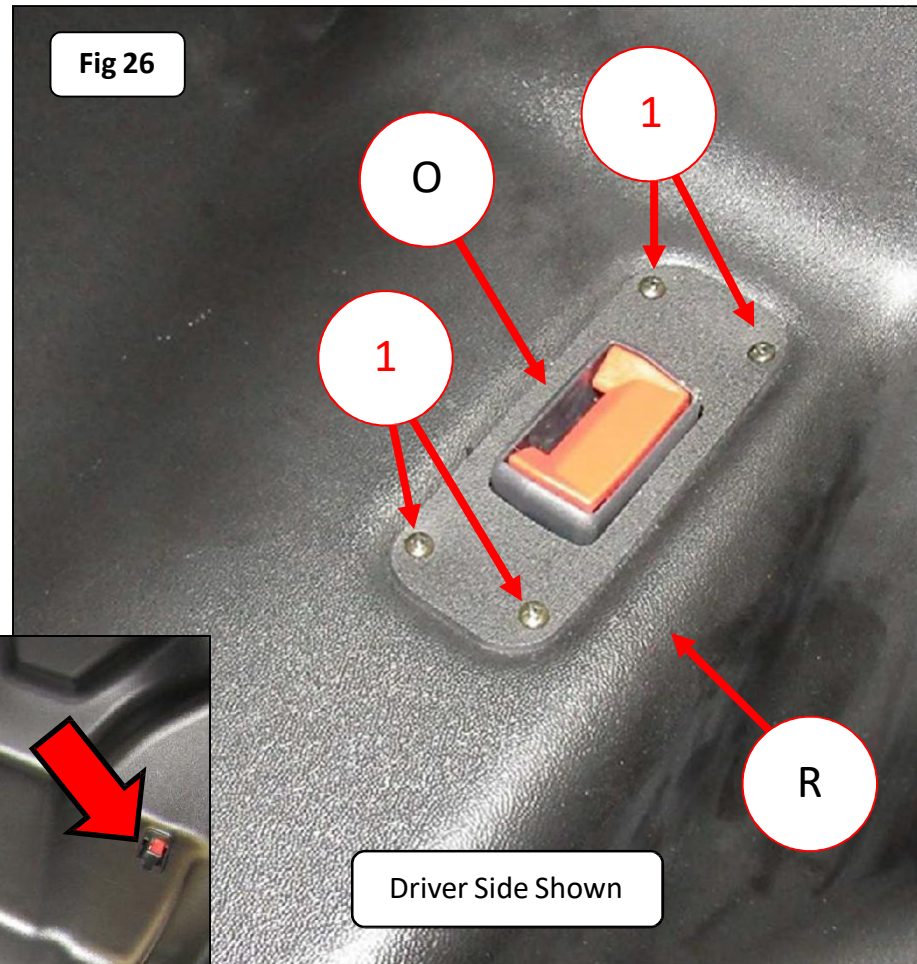
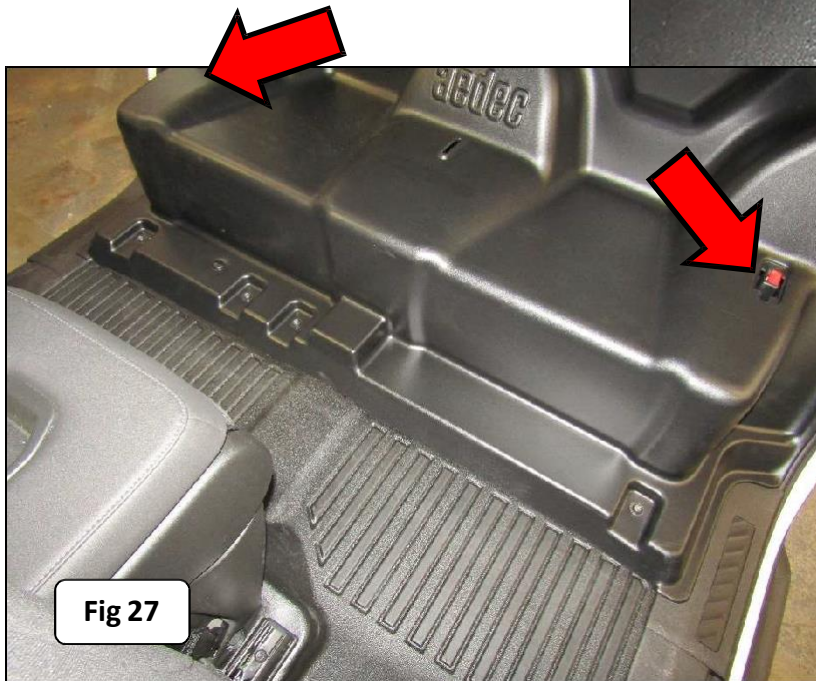

INSTALLATION INSTRUCTIONS:

Step-29 Using (1) Countersink screw attach (1) Round Base Magnet to each Retainer Cover located on the Center belt assembly, {Fig 28 & 29}.

Note: Do not overtighten Countersink screw.

***At this point assembly is complete.

Fig 28

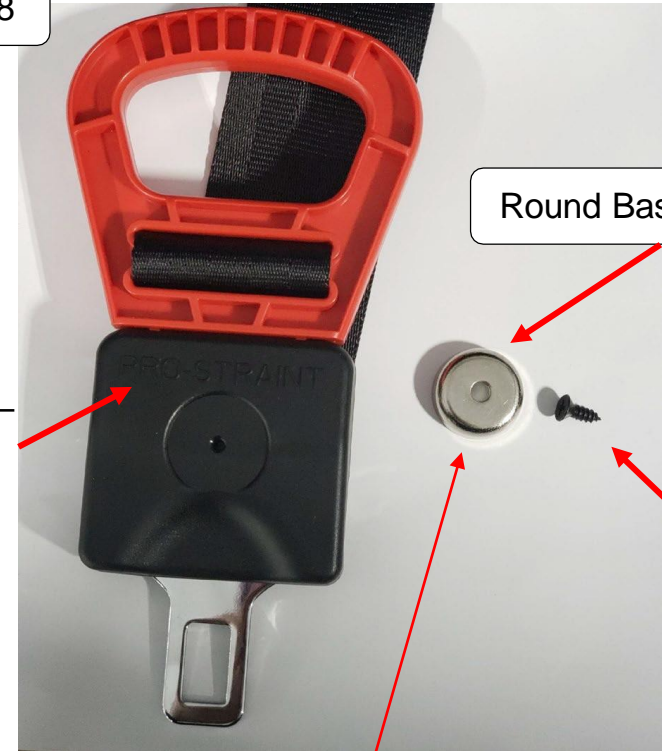

Fig 29

