

PUBLIC SAFETY DIVISION GO RHINO! PRODUCTS

PART NO. 570411

PARTITION INSTALLATION INSTRUCTIONS 2006-2010 DODGE CHARGER WITH SIDE CURTAIN AIR BAGS

PARTS LIST

QTY PART DESCRIPTION

- 1 5700CVW PARTITION ASSEMBLY
- 1 57261 DRIVER B-PILLAR BRACKET
- 1 57262 PASSENGER B-PILLAR BRACKET
- 1 57211 DRIVER LOWER FILLER PANEL
- 1 57212 PASSENGER LOWER FILLER PANEL
- 1 57251 DRIVER UPPER FILLER PANEL
- 1 57252 PASSENGER UPPER FILLER PANEL
- 4 #10-12 X 1" SELF DRILLING SCREW

QTY PART DESCRIPTION

- 1 57272 PASSENGER FOOT BRACKET ASSEMBLY
- 1 57271 DRIVER FOOT BRACKET ASSEMBLY
- 4 1/4" X 3/4" FLANGED HEAD SCREW
- 2 3/8" FLAT WASHER
- 2 3/8" X 1" CARRIAGE BOLT
- 2 3/8" NYLON LOCK NUT
- 2 3/4" X 2" VELCRO LOOP STRIP
- 2 3/4" X 2" VELCRO HOOK STRIP
- 4 1/4 x 1/2" FLANGED HEAD SCREW

INSTALLATION

READ THE INSTALLATION INSTRUCTIONS COMPLETELY BEFORE YOU BEGIN THE INSTALLATION

STEP – 1 ADJUST THE FRONT SEATS TO THE FORWARD POSITION AND REMOVE THE PASSENGER SIDE UPPER SEAT BELT MOUNTING BOLT. SET THE SEAT BELT ASIDE.

STEP – 2 REMOVE THE PASSENGER SIDE LOWER PLASTIC INTERIOR B-PILLAR COVER. TO REMOVE THE COVER, FIRST REMOVE THE TWO PHILLIPS HEAD SCREWS, THEN PULL UP THE DOOR JAMB MOLDING AT THE FRONT AND REAR DOORS AND REMOVE THE SCREW (FRONT SHOWN) BEHIND THEM. REMOVE THE LOWER COVER FROM THE VEHICLE **PHOTO'S #1 & #2**

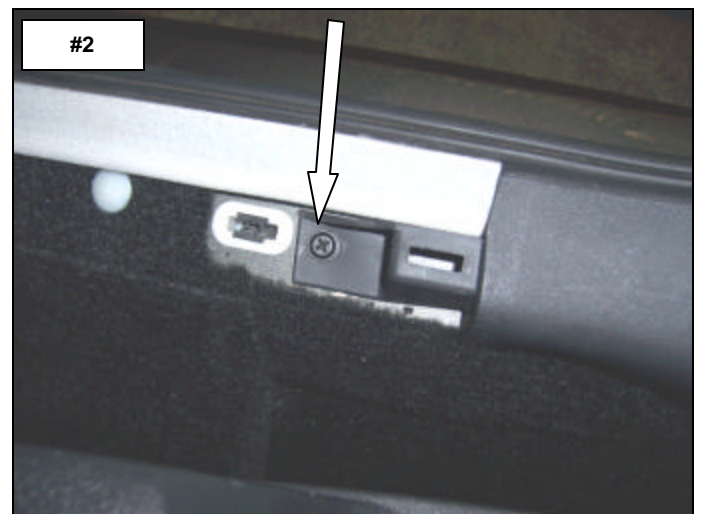
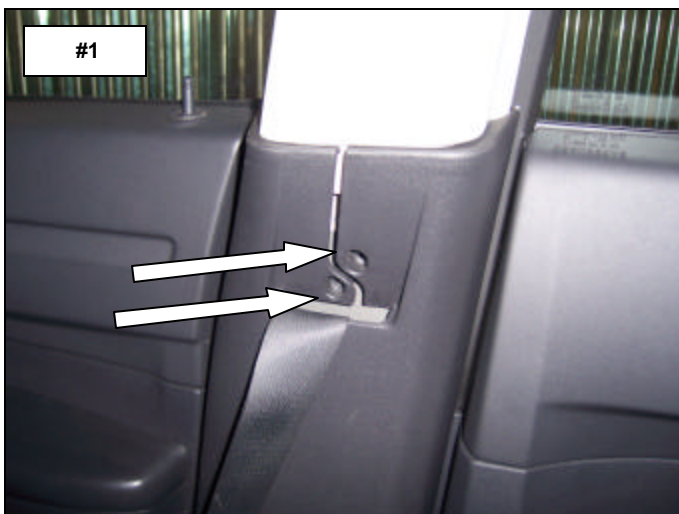

STEP – 3 REMOVE THE SINGLE SCREW HOLDING THE UPPER B-PILLAR COVER, PULL OUTWARD AND POSITION THE PASSENGER SIDE B-PILLAR BRACKET BETWEEN THE COVER AND B-PILLAR. RE-INSTALL THE UPPER COVER SCREW. **NOTE: PULL OUTWARD ENOUGH SO THE UPPER COVER ALIGNMENT PIN GOES THROUGH THE HOLE IN THE BRACKET AND B-PILLAR.** INSTALL THE LOWER COVER SCREWS TEMPORARILY AND USE THE OTHER TWO HOLES IN THE BRACKET AS YOUR DRILL POINTS. **PHOTO'S #3 & #4**

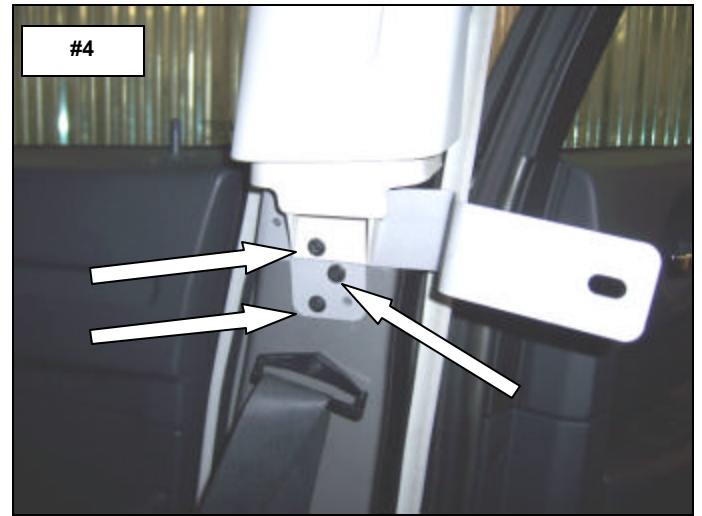
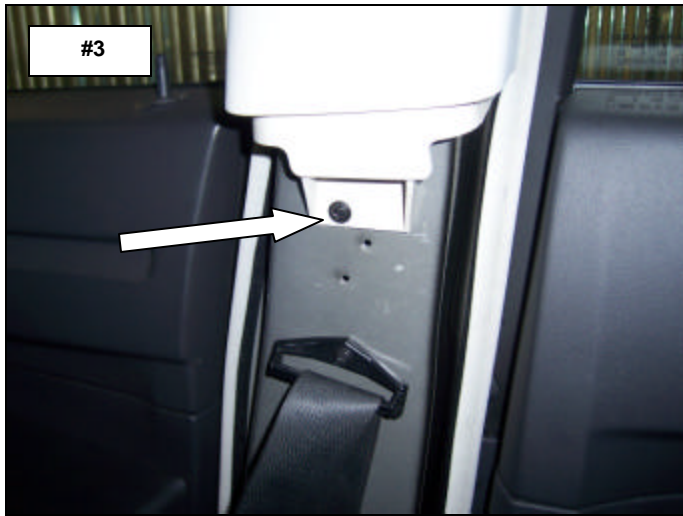

STEP – 4 USE TWO OF THE #10 SELF DRILLING SCREWS AND BOLT THE B PILLAR BRACKET IN PLACE, AND THEN REMOVE THE LOWER COVER SCREWS. **PHOTO #5**

STEP – 5 MEASURE, NOTCH AND REMOVE THE SECTION OF THE LOWER B-PILLAR COVER. **PHOTO #6**

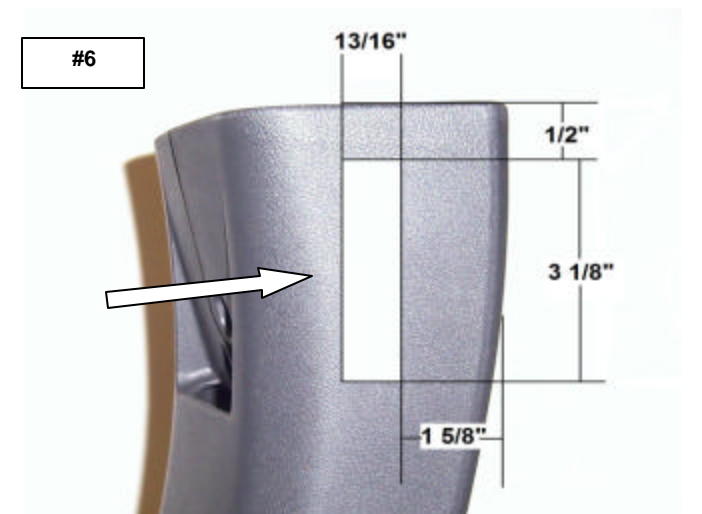
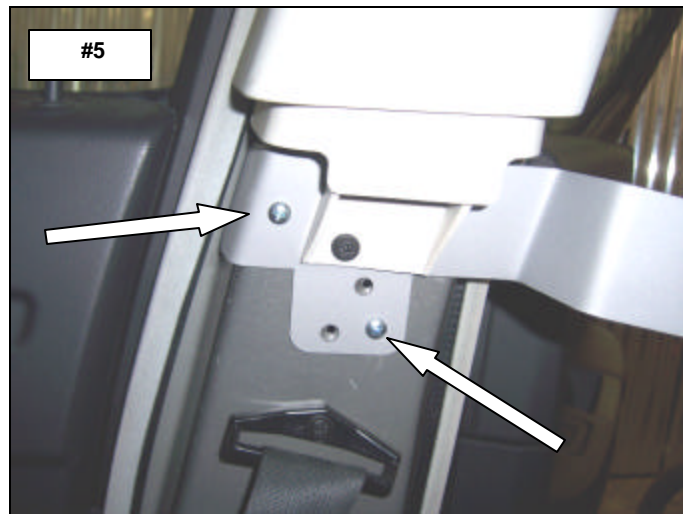

STEP – 6 REINSTALL THE LOWER B-PILLAR COVER AND THE UPPER SEAT BELT USING THE FACTORY MOUNTING SCREWS AND BOLT. REPEAT THE ABOVE PROCEDURE TO INSTALL THE DRIVER SIDE B-PILLAR BRACKET.

STEP – 7 LOCATE AND REMOVE THE DRIVER SIDE REAR SEAT TRACK BOLT. POSITION THE DRIVER SIDE FOOT BRACKET ASSEMBLY SO THE MOUNTING FLANGE IS LINED UP WITH THE BOLT HOLE IN THE SEAT TRACK AND REPLACE THE FACTORY BOLT. FINGER TIGHTEN ONLY. NOTE: THE FLANGE WILL GO INSIDE THE SEAT TRACK CHANNEL. **PHOTO'S #7 & #8**

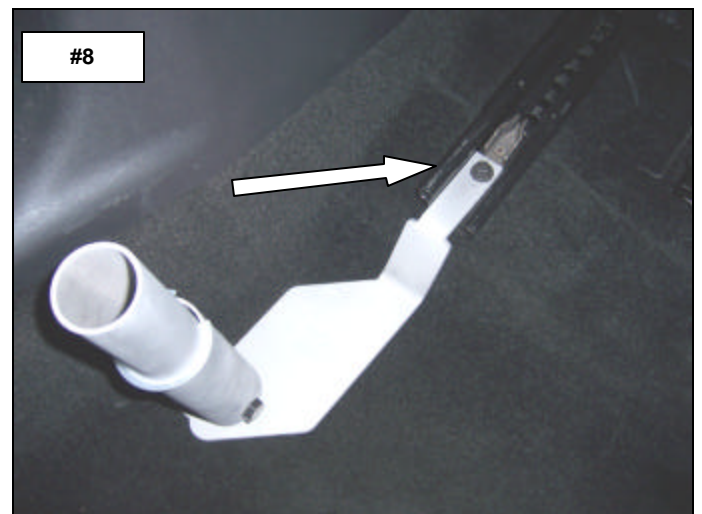
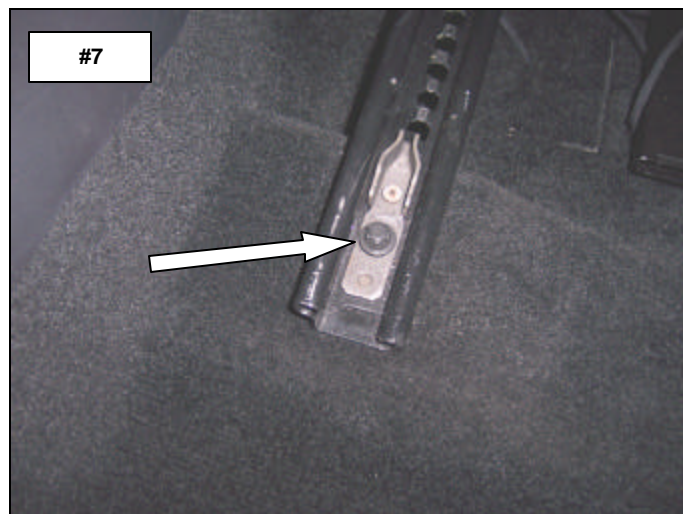

STEP – 8 LOCATE AND REMOVE THE PASSENGER SIDE REAR SEAT TRACK BOLT. POSITION THE FOOT BRACKET OVER THE SEAT TRACK MOUNTING FLANGE AND REINSTALL THE BOLT. FINGER TIGHTEN ONLY. **PHOTO'S #9 & #10**

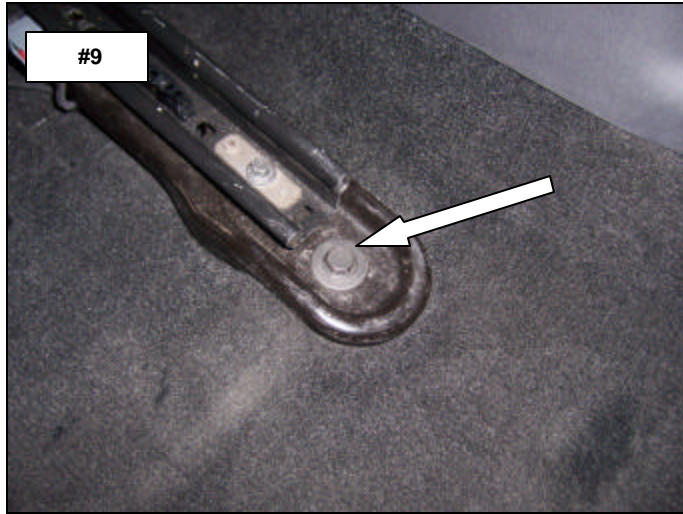

STEP – 9 WITH ASSISTANCE MOVE THE PARTITION INTO THE VEHICLE THROUGH THE REAR DOORS. LEAN THE PARTITION BACK AND ALIGN THE PARTITION LEGS WITH THE FOOT BRACKET STUB TUBES AND THEN SLIDE THE PARTITION LEGS OVER THE STUB TUBES. **PHOTO #11**

STEP – 10 PIVOT THE PARTITION ON THE FOOT BRACKETS UP TO THE B-PILLAR BRACKETS AND ATTACH THE PARTITION TO THE BRACKETS USING (1) 3/8" X 1" CARRIAGE BOLT, (1) FLAT WASHER AND (1) LOCK NUT PER SIDE. **PHOTO #12**

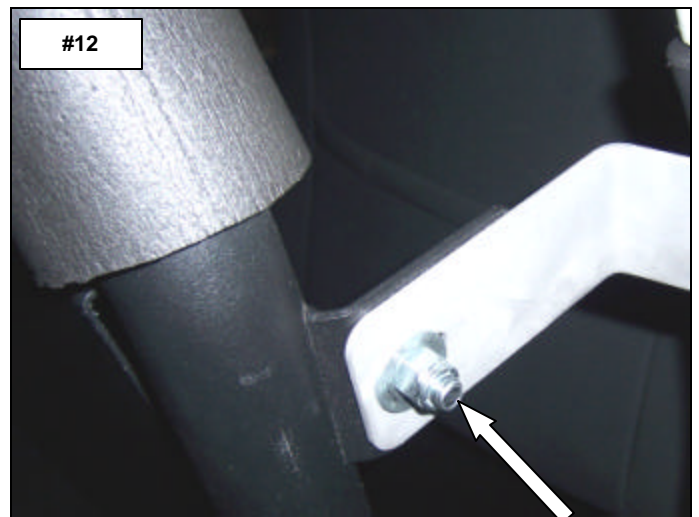

STEP – 11 ATTACH THE PASSENGER SIDE LOWER FILLER PANEL TO THE PARTITION USING (2) 1/4" X 3/4" FLANGED HEAD SCREWS. **PHOTO'S #13 & #14**



STEP – 12 MEASURE AND APPLY (1) VELCRO LOOP STRIP TO THE PASSENGER SIDE UPPER FILLER PANEL. **PHOTO #15**

STEP – 13 APPLY (1) VELCRO HOOK STRIP TO THE PARTITION UPPER FILLER PANEL TAB. **PHOTO #16**

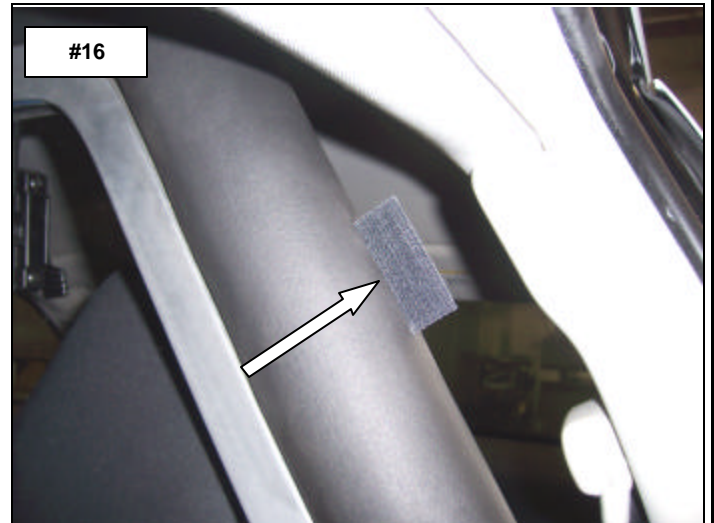
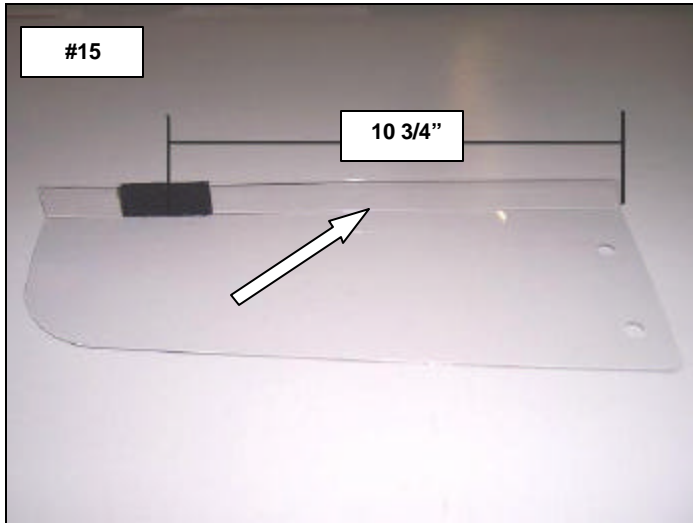

STEP – 14 ATTACH THE UPPER FILLER PANEL TO THE LOWER FILLER PANEL USING (2) $\frac{1}{4}$ X $\frac{3}{4}$ FLANGED HEAD SCREWS THEN PRESS THE UPPER PANEL VELCRO STRIP AGAINST THE PANEL TAB VELCRO STRIP TO CONNECT THE TWO. **PHOTO #17**

REPEAT THE ABOVE PROCEDURE TO INSTALL THE DRIVER SIDE UPPER AND LOWER FILLER PANELS.



**FOR TECHNICAL OR WARRANTY INFORMATION CALL:
TOLL FREE (888) 427-4466 FAX (714) 672-0278
GO RHINO! Products® 591 W. Apollo St. Brea, CA 92821**