

IMPORTANT

READ BEFORE YOU BEGIN INSTALLATION

IT IS CRITICAL FOR YOUR SAFETY THAT YOU CAREFULLY READ AND FOLLOW THE SAFETY CAUTIONS AND INSTALLATION INSTRUCTIONS BOTH PRIOR TO AND DURING INSTALLATION.

USER SAFETY CAUTION

During installation, be mindful of the potential for sharp edges on the product or vehicle. Taking proper safety precautions helps ensure a safe and smooth installation process.

Always wear protective gloves and handle components with care to reduce the risk of injury.



TEMPERATURE SURFACE CAUTION

During high temperatures or extended sun exposure, surfaces of this product may become hot to the touch, posing a risk of burns or injury. Use caution when handling the product in hot weather and allow time for it to cool before contact.

Always check surface temperature before use to ensure safe handling conditions.



FASTENER TORQUE CAUTION

All fasteners must be tightened to the specified torque values provided in the installation instructions to ensure proper fit and safe operation of the tonneau cover. Under- or over-tightening can lead to product failure, potential damage to your vehicle, injury, or safety hazards while driving.

Always use a calibrated torque wrench and follow the specifications in the installation instructions.



PINCH POINT SAFETY CAUTION

This tonneau cover may create pinch points when closing or operating near solid surfaces such as the truck bed rails or tailgate. To prevent injury, keep hands, fingers, and other body parts clear of moving parts during operation.

Always operate the cover slowly and with caution to ensure safe and proper use.



IMPORTANT

READ BEFORE YOU BEGIN INSTALLATION

IT IS CRITICAL FOR YOUR SAFETY THAT YOU CAREFULLY READ AND FOLLOW THE SAFETY CAUTIONS AND INSTALLATION INSTRUCTIONS BOTH PRIOR TO AND DURING INSTALLATION.

ENTRAPMENT SAFETY WARNING

This tonneau cover does not feature a manual release mechanism from inside the truck bed. To prevent the risk of entrapment, never allow anyone to be inside the bed of the truck when the cover is closed.

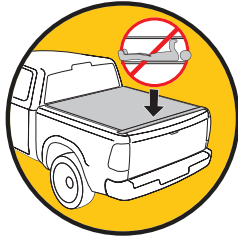

Always ensure the area is clear before closing the cover, and keep the cover securely latched when not in use to avoid accidental closure.

COVER ATTACHMENT WARNING

A partially rolled up or unsecured cover may detach during transit, risking vehicle or property damage and personal injury.

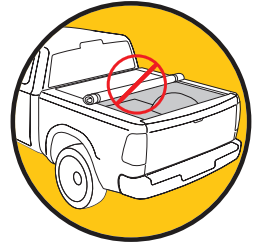

Always verify the tonneau cover is properly secured before operating the vehicle.

CARGO TRANSPORT WARNING

When transporting cargo that is taller than the truck bed, the cover must be fully rolled open and securely fastened with both retainer straps. An unsecured cover can detach while driving, risking vehicle or property damage and personal injury.



Never operate the vehicle with a partially rolled up cover.

COVER POSITION WARNING

Before operating the vehicle, always verify the tonneau cover is either fully rolled open and secured with both retainer straps or fully rolled closed and securely latched down.

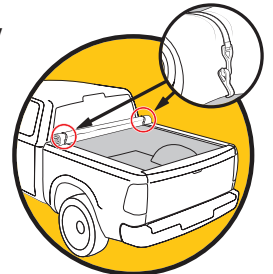

Never operate the vehicle if the tonneau cover is not properly secured.

GATOR

FORD RANGER 24-25 SRX & SR3 SOFT ROLL-UP INSTALLATION SHEET

Any damaged or missing parts?

Parts will be shipped to you directly.

Call 855-427-4568, Mon - Fri, 8:00 a.m.- 9:00 p.m. EST,
Sat 9:00 a.m. - 8:00 p.m. EST.

NOTE: It is important that all the areas where the bed cover mounts to the truck are clean and free of debris before installation.

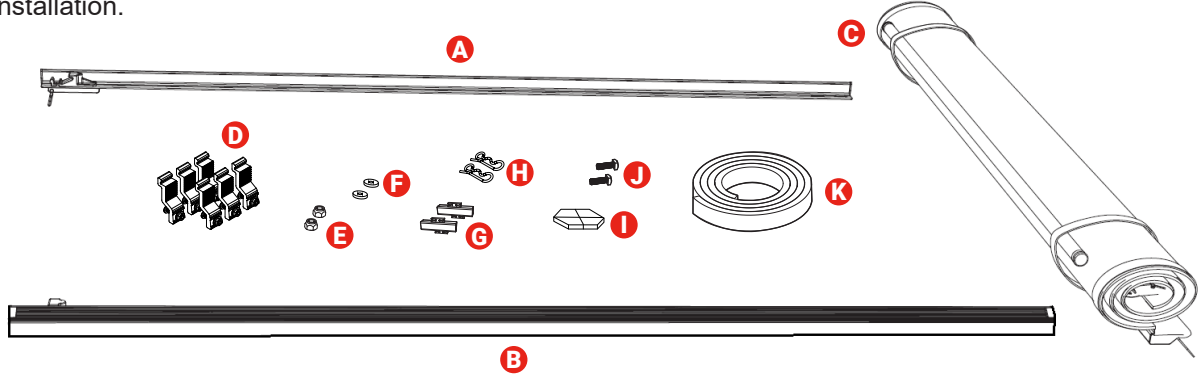

PARTS INCLUDED IN YOUR KIT

- A** Driver side rail
- B** Passenger side rail
- C** Cover assembly
- D** 6x clamps
- E** 2x Hex nuts
- F** 2x Plastic washers
- G** 2x Tension adjustment blocks
- H** 2x Hitch pins
- I** 1x Weather seal pack
- J** 2x Bolts
- K** Bulkhead seal

TOOLS REQUIRED

- T-30 Drive socket or T-handle wrench
- Isopropyl alcohol

TOOLS RECOMMENDED

- Spring clamps
- Scissors/utility knife

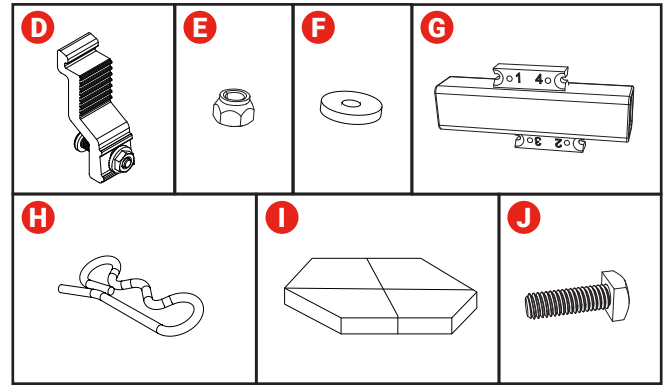

1 The serial number for the cover is located here.

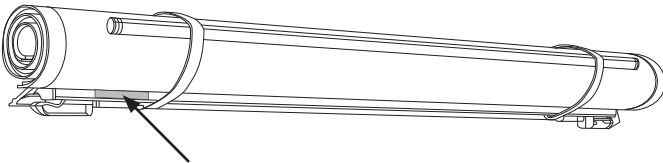

For future reference, write it here:

2 It is important that all areas where the bed cover mounts are clean and free of debris prior to installing.

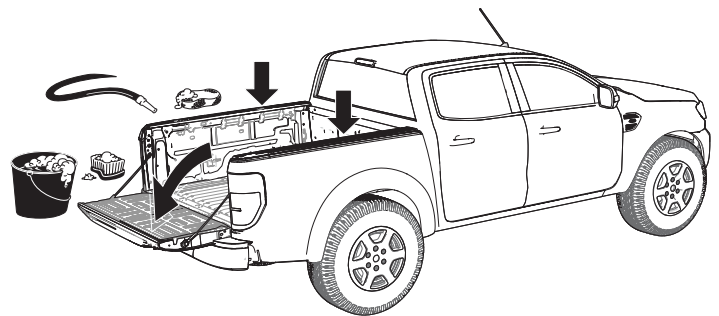

3 Install the bulkhead weather seal (K) to the truck's front bulkhead. Clean the area where the seal will go with soap and water to remove dirt and debris. Then clean the area with isopropyl alcohol to remove wax or grease and to evaporate any remaining water, allow the surface to dry. Then position the seal and apply pressure to the entire seal to make sure the adhesion is good.

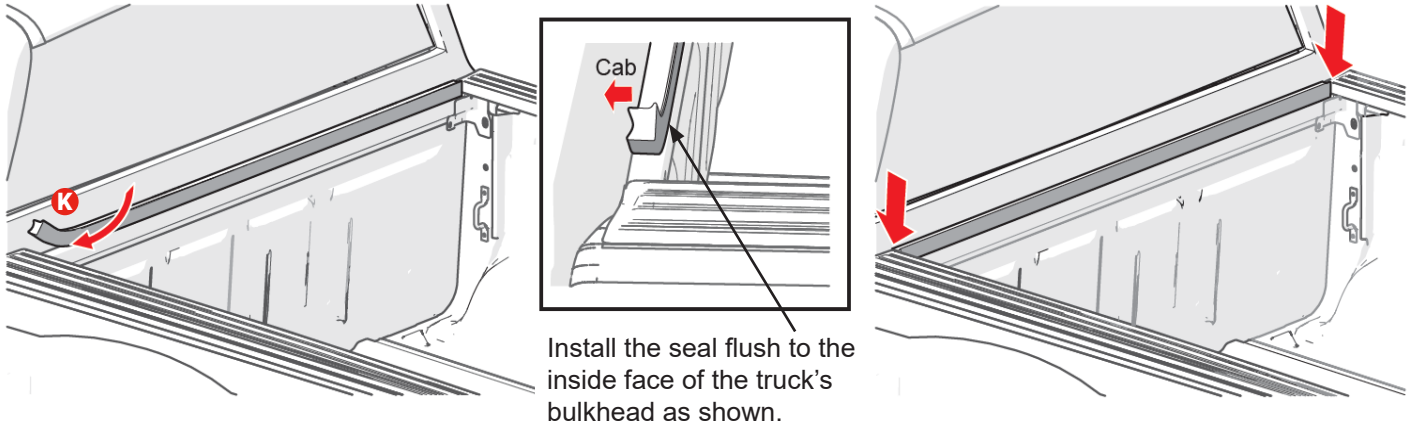

4 Install the six clamp brackets (D) to the truck box. Leave hardware loose at this time.

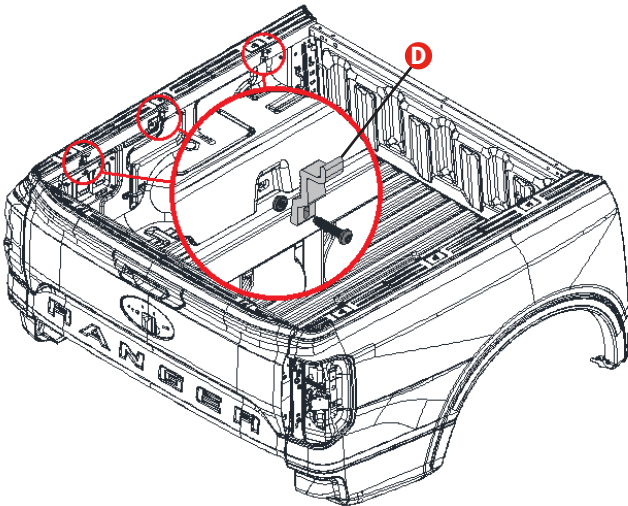

5 Peel and stick the foam weather seals (I) to each end of the driver and passenger side rails (A & B).

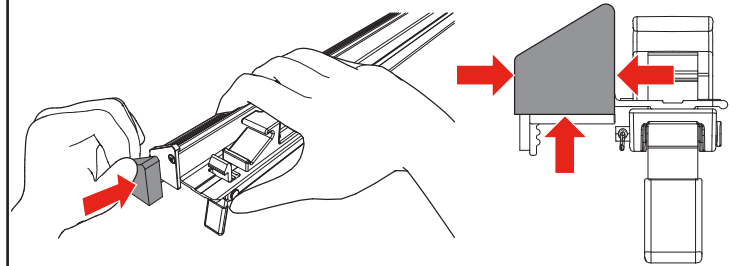

6 Position the driver side rail (A) against the truck bed rail. With the tailgate closed, slide the rail back until the rear seal is slightly compressed against the tailgate. Adjust the rail vertically so that the seal is flush with the truck bed caps.

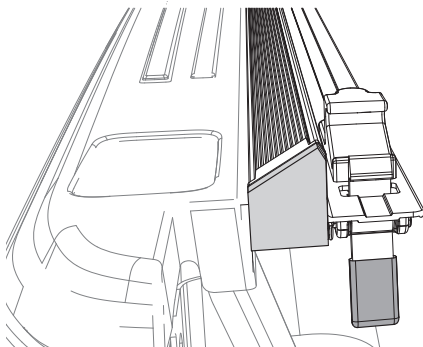

NOTE: The trigger latch is included on the driver side rail only.

7 For optimal latching performance and cover fit, the side rails (A & B) should be level with the truck bed caps and not tilted up or down. To fine-tune side rail tilt, you can reposition the clamps upwards or downwards slightly. Tighten all clamps with a T-30 drive socket or T-handle wrench.

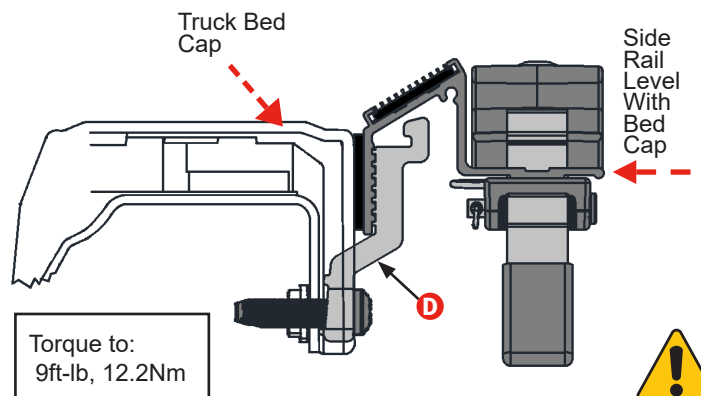

8 To install the tension blocks (G) insert the blocks labeled with holes 2 & 3 into the rectangle cut out on the side rails (A & B). The upper block, labeled with hole 4, will be positioned on the top towards the cab. Make sure the tension blocks are pushed up against the front header.

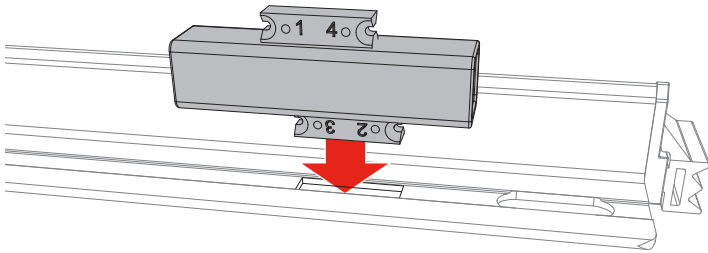

9 Secure the tension blocks to the side rails (A & B) by inserting the hitch pins (H), into hole number 2 on the underside of the side rails. If your covers tension is too tight or too loose simply remove the tension blocks and reposition. See chart on page 4 to fine tune your tension blocks once the cover is fully installed.

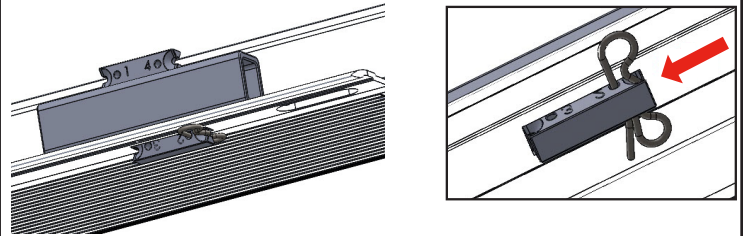

(Driver Side Rail and Pin Shown)

10 On the cover assembly (C), identify the driver and passenger front header end plugs. Remove both plugs by pulling them outward as shown below.

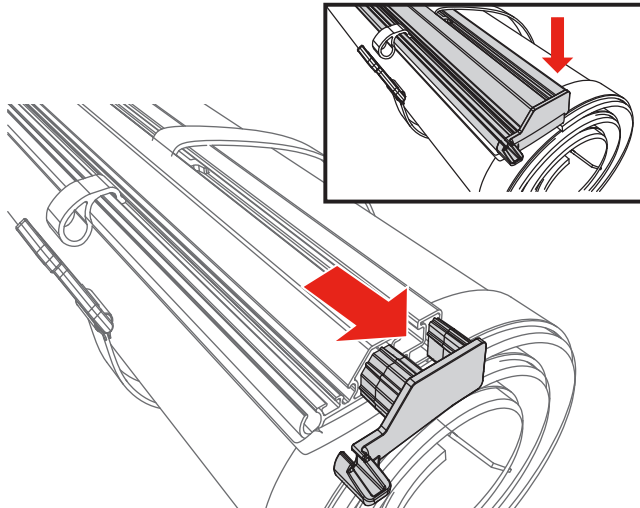

11 Install the bolts (J) by sliding them into the header as shown below. Do this on both driver and passenger sides.

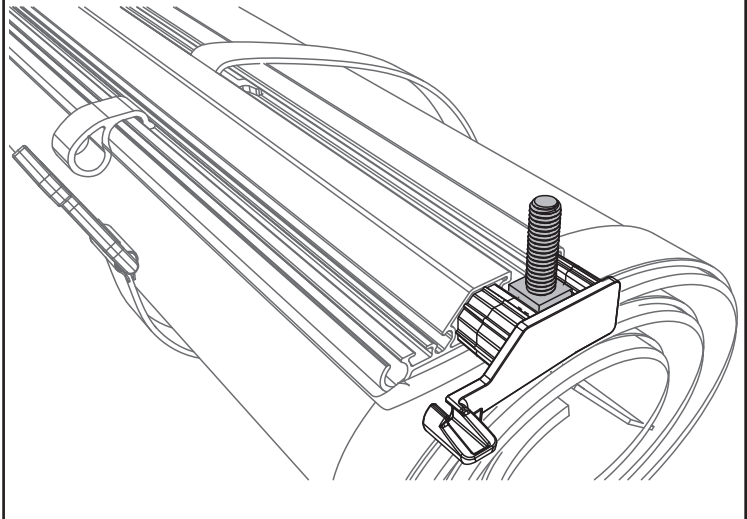

12 Reinstall both end plugs as shown below.

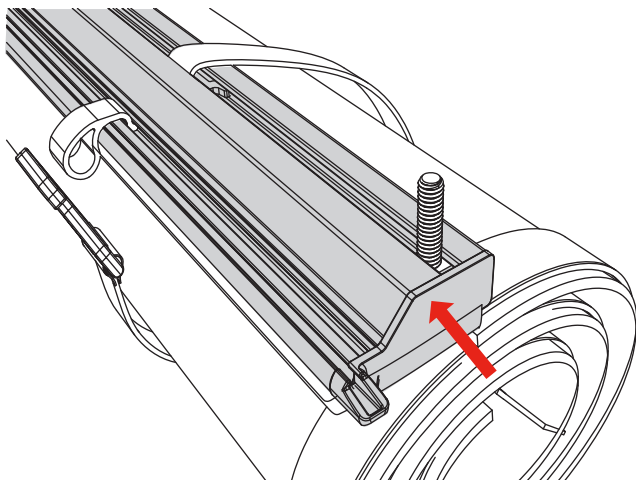

13 Place the cover (C) on the side rails (A & B) towards the front of the truck bed (near the cab). The front header seal is designed to help shed water and should be sitting on top of the bulkhead.

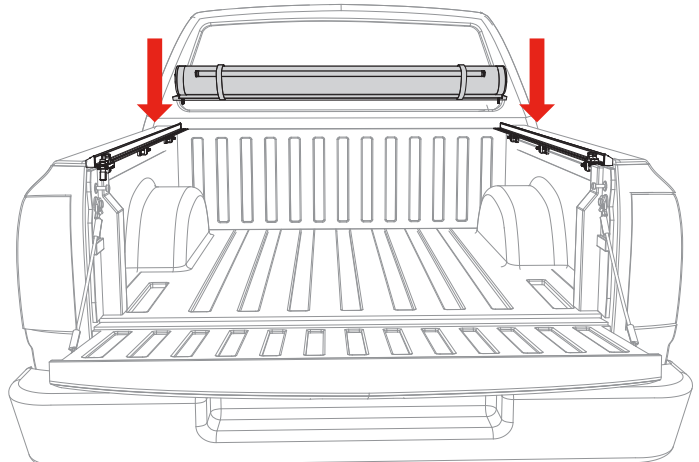

14 To connect the cover to the rails (A & B) thread the plastic washers (F) and hex nuts (E) onto the bolts (J) attached to the cover (C). Tighten with a 9/16" wrench or socket. Do **NOT** overtighten. Insert bolts on the bottom of the cover (C) through the slotted bracket in the driver and passenger side rails (A & B).

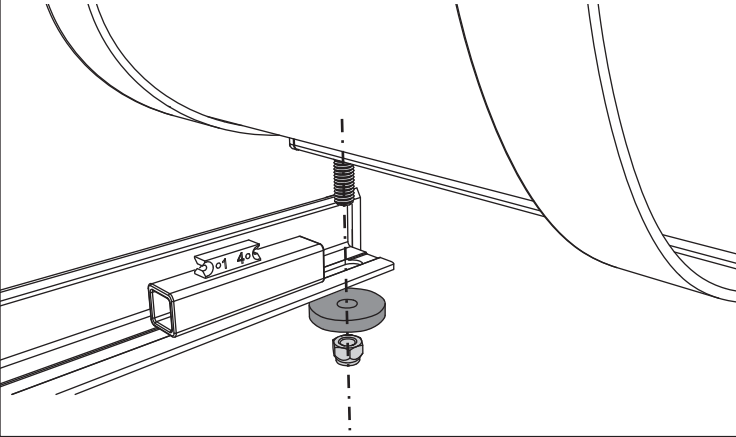

15 Unroll the cover (C) evenly towards the tailgate.

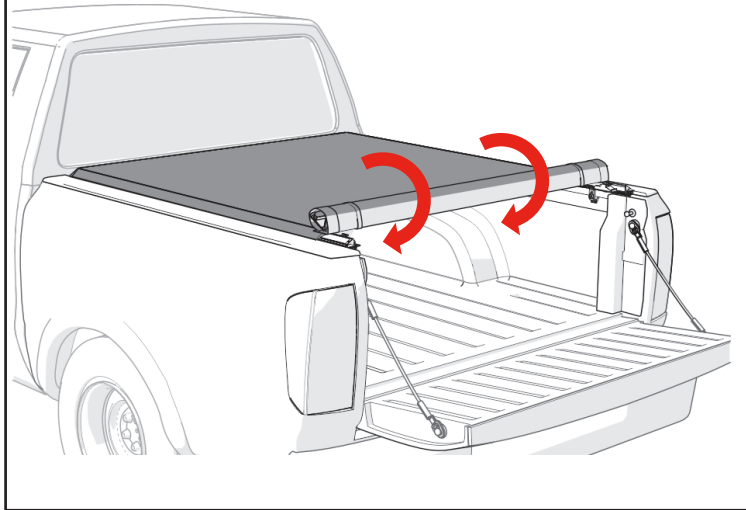

16 Place the rear header into the header stops which are located on both side rails (A & B). Rotate the rear header downwards until you feel the cover latch in place. A clicking sound will indicate a correctly installed cover.

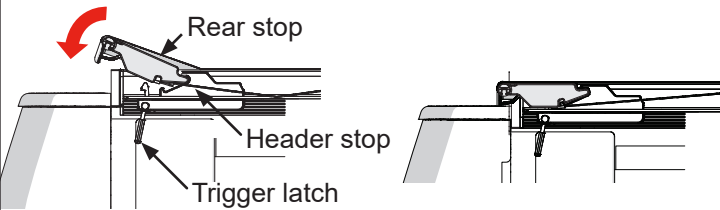

Preferred method of closure: Close tailgate, then close cover on top of the tailgate. This method will not work with some truck applications. Use alternative method instead.

Alternative method of closure: Close tailgate, then close cover on top of the tailgate. This method will not work with some truck applications. Use alternative method instead.



17 To secure the hook and loop grab the fabric and pull evenly over the hook track to engage the hook and loop.

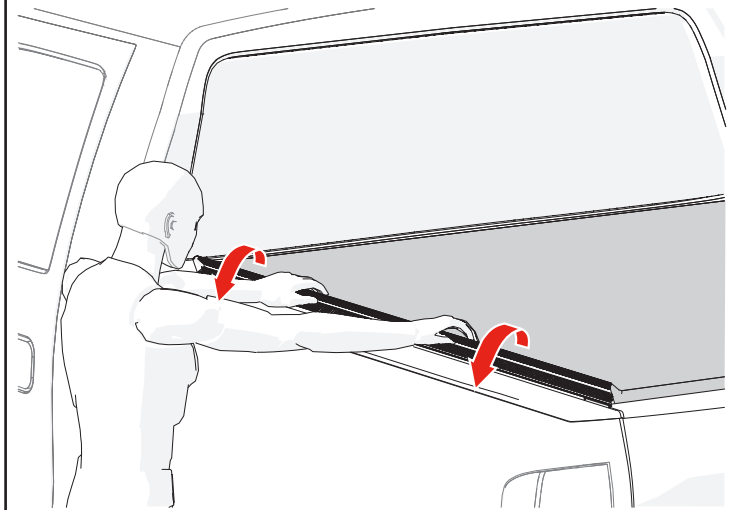

18 Once the side of the hook and loop are engaged, use the palms of your hand to firmly push the loop strip into the hook track the entire length of the cover. This will prevent wind from lifting the cover and causing possible damage. Do this on both driver and passenger sides.

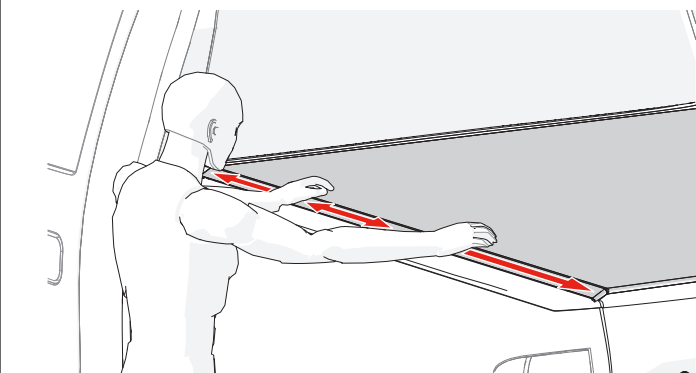

HOOK AND LOOP MUST ALWAYS BE ADJUSTED AFTER ROLLING COVER CLOSED.



COVER IN THE CLOSED POSITION

You are ready to drive with the cover in the closed position. **NOTE:** If the tailgate has a key lock, the cover is secured until the tailgate is unlocked and opened.

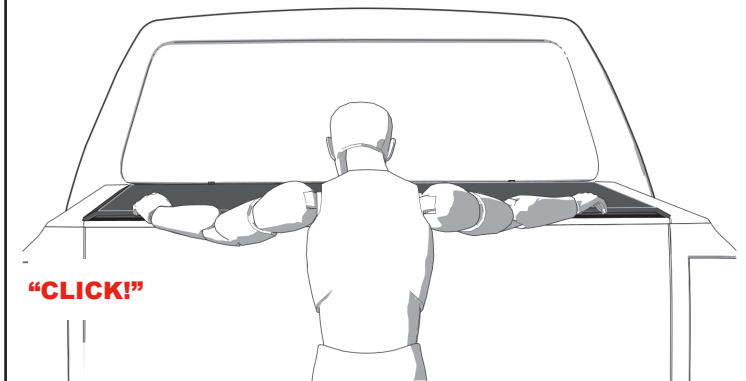

"CLICK!"

COVER IN THE OPEN POSITION

To drive with the cover in the open position, pull the latch towards you to release the cover (located on driver side rail). Roll the cover toward the cab of the truck, making sure that both sides roll evenly. Secure the cover by placing both retainer hooks into the retainer loops **You are ready to drive with the cover in the opened position.**

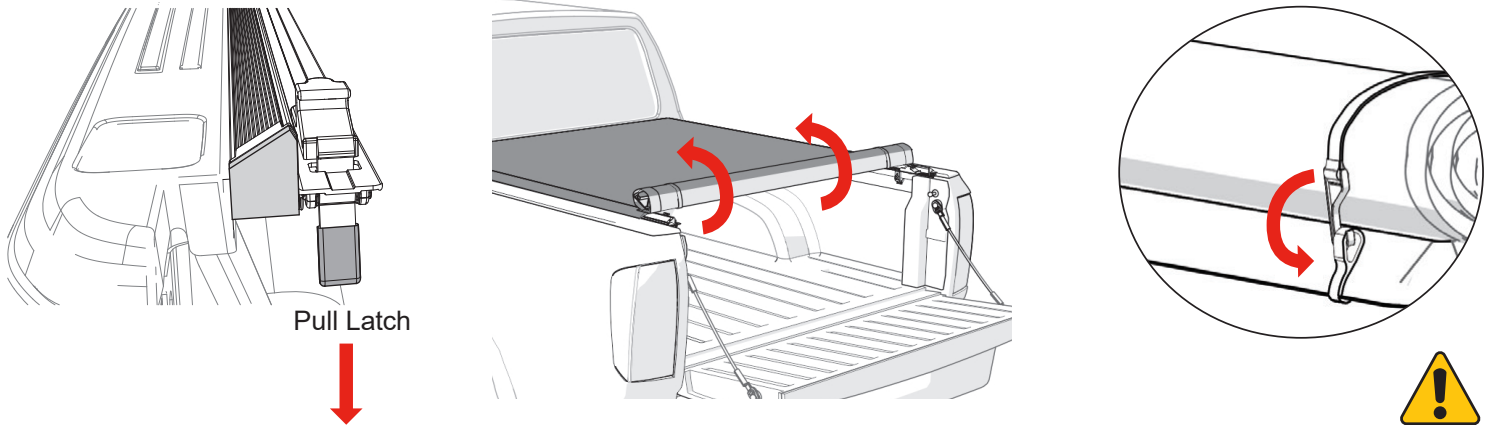

FINE TUNING TENSION ADJUSTMENT BLOCKS

SETTING COVER TENSION

- Roll the cover (C) open to adjust both tension blocks (G).
- Pull hitch pin (H) and rotate tension blocks (G) to the desired position.
- Replace hitch pin (H). **Driver and passenger blocks must always be in the same position.**
- Close cover and check adjustment. Repeat until satisfactory tension has been achieved.

ATTENTION: Proper tension allows the cover to look and perform at its best. If the cover feels too tight or too loose when opening or closing it, adjust the tension during the warmest part of the day.

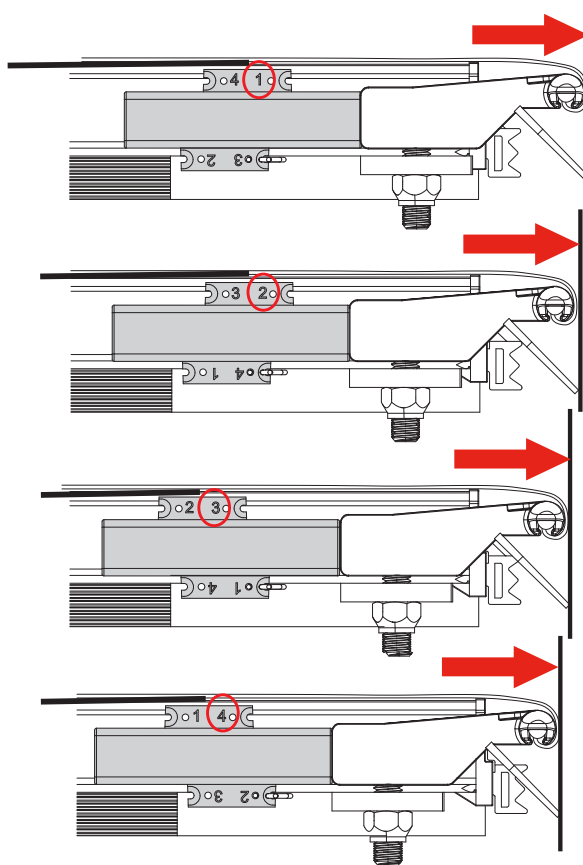

Position 1 is set for maximum forward tension. The **NUMBER 1** is positioned on the top front. The hitch pin always goes into the bottom front hole.

Position 2 is set for less forward tension. The **NUMBER 2** is positioned on the top front. The hitch pin always goes into the bottom front hole.

Position 3 is set for less forward tension. The **NUMBER 3** is positioned on the top front. The hitch pin always goes into the bottom front hole.

Position 4 is set for least forward tension. The **NUMBER 4** is positioned on the top front. The hitch pin always goes into the bottom front hole.

SAFETY INSTRUCTIONS

- DO NOT place objects on or against the cover or framework.
- NEVER allow children or pets to occupy the pickup box while the cover is closed.

TROUBLESHOOTING TIPS

WHY IS MY COVER HOLDING WATER AFTER IT RAINS?

- Water pooling on the cover is normal because our cross bows are not arched. Since they are designed to sit flat some water may accumulate on the top of the cover. Once you drive your truck, the water will shed from the cover.
- Make sure to retighten the hook and loop fasteners along the length of the bed.

WRINKLES ON THE VINYL FABRIC AFTER ROLLING COVER CLOSED

- Pull the vinyl fabric taut from each side. For best results, the help of a second person pulling on the opposite side is preferable.

SAGGING VINYL FABRIC BETWEEN THE CROSS BOWS

- Adjustment to tension blocks may be required.

WIND LIFTS UP THE EDGE OF THE VINYL FABRIC

- Make sure to engage the hook and loop on the driver and passenger side rails after closing the cover. This may need to be done periodically when taking long trips.

VINYL FABRIC FLUTTERS EXCESSIVELY WHEN DRIVING

- Adjustment to tension blocks may be required.
- Make sure hook and loop fasteners are set. See Step 17-18.

SNOW AND ICE ACCUMULATION ON THE VINYL FABRIC

- Use broom or brush to remove loose snow and ice. DO NOT use sharp or pointed tools to remove snow and ice.
- Direct sunlight will help melt snow and ice off the vinyl fabric.

TONNEAU COVER WILL NOT LATCH

- Check side rails to make sure they are level. See Step 7.
- Make sure the header seal is not caught between side rails & header.
- Check the position of side rails on the pickup box. They may be positioned too low. See Step 7.
- Make sure the cover has proper tension. See fine tuning tension blocks section.

VINYL FABRIC IS TOO TIGHT OR TOO LOOSE

- Adjustment to tension blocks may be required.

VINYL FABRIC HAS SHIFTED TOO FAR TO ONE SIDE

- Unlatch the cover at the tailgate, release the hook and loop along both sides, go to the shorter side of the tarp and tug. The vinyl fabric will slide in the aluminum headers. Pull on the shorter side until the tarp appears centered on the whole system.
- Latch the cover and secure the hook and loop down both sides. Repeat if more adjustment is needed.

COVER CARE AND MAINTENANCE

- Clean with mild automotive soap and water. Never use vinyl conditioners that contain silicon, petroleum, or citrus based products on your truck bed cover as they may crack and shrink the vinyl top surface.

IMPORTANT OPERATING TIPS

- After closing the cover, the operator must secure the hook and loop by running their hand down the driver and passenger side rails, pushing down on the cover material.
- If the side rails are tipping, adjust the clamps in order to level the side rails and ensure a proper fit.

LIMITED WARRANTY

WARRANTY COVERAGE

This truck bed cover is warranted against defects in materials or workmanship as follows. This warranty is void if the product has been damaged in an accident, or due to neglect, unforeseeable use, improper installation, improper servicing, or other cause not arising out of defects in material or workmanship.

LIMITED 2-YEAR WARRANTY ON HARD PARTS

All hardware included with your truck bed cover, including rails, clamps and bows carry a limited 2-year warranty, subject to the terms below.

LIMITED 2-YEAR WARRANTY ON THE FABRIC

The fabric on your truck bed cover carries a limited warranty for two (2) years from the original date of purchase, subject to the terms below.

WARRANTY IS NOT TRANSFERABLE

The warranty is to the initial consumer purchasing the truck bed cover and it is not transferable to a subsequent end user. Proof of purchase may be required to enforce these warranty rights.

WARRANTY CONDITIONS

Failure to follow these warnings and care instructions will void the warranty:

- Clean with mild automotive soap and water only.
- Do not use conditioners that contain silicone or petroleum.
- The tonneau cover must be secured at all points when the vehicle is in motion. When not fully closed with the rear latch engaged the cover must be completely rolled up and secured at the cab with both provided retainer straps attached. Do NOT drive with the bed cover in a partially open position.
- Cargo should not contact the tarp at any point. Protrusions in the tarp will stress the vinyl fabric. Cargo may also shift while traveling causing it to press against the vinyl fabric and damage it.
- Check rail clamps for tightness after a week of driving following the installation of the cover and periodically thereafter.
- Do NOT roll the cover into the rear cab window. Do NOT stow the cover against the cab of the truck.
- If the cover is going to be rolled open for an extended amount of time, periodically re-roll the cover and secure the retainer straps to ensure the cover doesn't rest against the cab of the truck.
- Before opening, the cover must be free of all foreign materials including snow and ice.
- Do NOT tow your vehicle from the rear with the cover on your vehicle. If towing from the rear is required, the cover MUST be removed from the vehicle and properly stored.

WARRANTY PERFORMANCE

If all warranty conditions are met, a defective truck bed cover, tarp, or hardware component will either be repaired or replaced (at our option). We reserve the right, for any warranty, to substitute a newer model of bed cover having similar form and function, to offer a warranty discount on an entire replacement system, and/or provide remedies other than those mentioned in this document.

WARRANTY PROCESS

A Return Material Authorization number must be obtained from our Customer Service Department prior to returning any product. We may require the original item to be returned postage prepaid for final determination. Shipping charges will apply for any repair or replacement. Other than postage or shipping charges, no charge will be made for repair or replacement under this warranty.

This warranty gives you specific legal rights. As a consumer, you may also have additional rights and remedies under the laws of your state.

WARRANTY REGISTRATION

Warranty registration must be on file and/ or proof of original purchase (detailed and dated receipt) required for warranty to be effective.

To register your warranty, please visit: <https://realtruck.com/warranty-registration>

**REGISTER
YOUR
WARRANTY
ONLINE**



REPLACEMENT PARTS

To order replacement parts, it is best to contact our Customer Service Department for assistance to ensure that you get the correct part for your vehicle application.

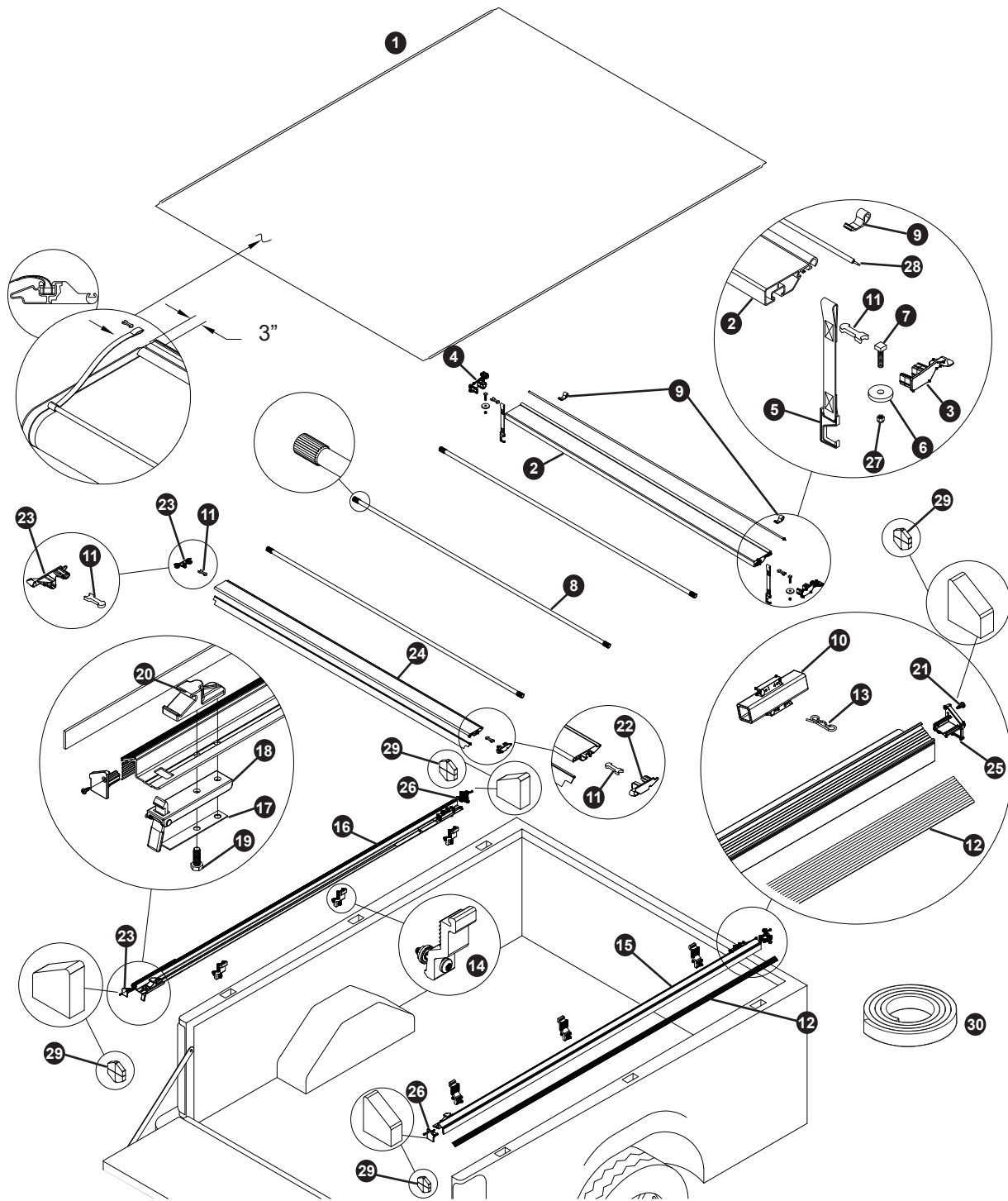

REPLACEMENT PARTS

1	*	Replacement Cover	11	1705364	Header Insert Retainer Clip	20	1705336	Header Stop
2	*	Front Header	12	*	Hook Strip	21	1706547	Self Drill Screw
3	1705310	Front Header End Plug RH	13	1707003	Hitch Pin	22	1705405	Rear Header End Plug RH
4	1705311	Front Header End Plug LH	14	1707172	Aluminum Clamp Single (1) 1118939 Clamp Screw Pack (6)	23	1705404	Rear Header End Plug LH
5	*	Retainer Strap	15	*	Side Rail, Passenger's Side	24	*	Rear Header
6	1115745	Plastic Washer	16	*	Side Rail, Driver's Side	25	1706421	Side Rail End Plug LH
7	1703455	Square Head Cap Screw	17	1705727	Flat Spring	26	1706422	Side Rail End Plug RH
8	*	Bow Assembly	18	1704213	Latch Assembled	27	1701580	Hex Nut Full Nylon Lock
9	1705192	Retainer Loop	19	1703455	Cap Screw	28	*	Extruded Header Seal
10	1705318	Tension Adjustment Block				29	1706424	Four Corner Seal Pack
						30	1118420	Bulkhead Seal

* Please specify length or make and model of vehicle.